

Health and Physical Education

Textbook for Class X



विद्यया ऽ मृतमश्नुते



एन सी ई आर टी
NCERT

राष्ट्रीय शैक्षिक अनुसंधान और प्रशिक्षण परिषद्
NATIONAL COUNCIL OF EDUCATIONAL RESEARCH AND TRAINING

1077 – HEALTH AND PHYSICAL EDUCATION

Textbook for Class X

ISBN 978-93-5292-335-9

First Edition

August 2020 Shrawana 1942

Reprinted

October 2021 Ashwin 1943

January 2025 Magha 1946

PD 30T GS

© **National Council of
Educational Research and
Training, 2020**

₹ **180.00**

Printed on 80 GSM paper

Published at the Publication Division by the Secretary, National Council of Educational Research and Training, Sri Aurobindo Marg, New Delhi 110016 and printed at D.P. Printing & Binding, B-149, Okhla-I, A-1, New Delhi-110020

ALL RIGHTS RESERVED

- ❑ No part of this publication may be reproduced, stored in a retrieval system or transmitted, in any form or by any means, electronic, mechanical, photocopying, recording or otherwise without the prior permission of the publisher.
- ❑ This book is sold subject to the condition that it shall not, by way of trade, be lent, re-sold, hired out or otherwise disposed of without the publisher's consent, in any form of binding or cover other than that in which it is published.
- ❑ The correct price of this publication is the price printed on this page. Any revised price indicated by a rubber stamp or by a sticker or by any other means is incorrect and should be unacceptable.

OFFICES OF THE PUBLICATION

DIVISION, NCERT

NCERT Campus
Sri Aurobindo Marg
New Delhi 110 016 Phone : 011-26562708

108, 100 Feet Road
Hosdakere Halli Extension
Banashankari III Stage
Bengaluru 560 085 Phone : 080-26725740

Navjivan Trust Building
P.O.Navjivan
Ahmedabad 380 014 Phone : 079-27541446

CWC Campus
Opp. Dhankal Bus Stop
Panihati
Kolkata 700 114 Phone : 033-25530454

CWC Complex
Maligaon
Guwahati 781 021 Phone : 0361-2674869

Publication Team

Head, Publication Division : *M.V. Srinivasan*

Chief Editor : *Bijnan Sutar*

Chief Production Officer (In Charge) : *Jahan Lal*

Chief Business Manager : *Amitabh Kumar*

Assistant Production Officer : *Deepak Kumar*

Cover and Layout

DTP Cell, PD

FOREWORD

Health of children is a major concern worldwide. Their health is very important as they constitute a large percentage of our population. Many factors like physical, psychological, socio-economic and cultural influence our health, both in our day-to-day life and in the long run. The involvement of all children in physical activities, games and sport, and yoga along with authentic knowledge is essential for their physical, emotional, social and mental development. In this endeavour, school education plays an important role. All the National Curriculum Frameworks have recommended health and physical education as an integral part of the school curriculum. With this view, the National Council of Educational Research and Training (NCERT) has prepared this textbook on Health and Physical Education for Class X.

This textbook focuses on the holistic understanding of physical education and its relationship with other subjects and the effects of physical activities on human body. It also provides a scope for children to learn the theoretical, as well as, the practical aspects of individual and team games. Further, it discusses yoga, dietary considerations, safety measures for healthy living, social health, agencies and awards promoting health, sports and yoga. The information about coronavirus (COVID-19), its modes of transmission and prevention have also been included at relevant places to help the children remain safe and healthy. Keeping in view the inter-related nature of the concepts covered in the area of Health and Physical Education, the presentation is made in a cohesive and an integrated manner rather than adopting a fragmentary approach. Experiential learning activities for acquiring skills for healthy living are made an integral part of the book.

The NCERT appreciates the efforts of the Textbook Development Committee. Several experts and teachers have contributed towards the finalisation of this book. We are grateful to them and their institutions. I am thankful to Professor Saroj Yadav, *Dean (Academic)* and the *Project Coordinator* of the National Population Education Project (NPEP) for her continuous efforts in developing this material and bringing it to its present form.

As an organisation committed to systemic reform and continuous improvement in the quality of our products, the NCERT welcomes comments and suggestions from teachers and students, which will enable us to undertake further revision and refinement.

Hrushikesh Senapaty
Director

National Council of Educational
Research and Training

New Delhi
May, 2020

© NCERT
not to be republished

TEXTBOOK DEVELOPMENT COMMITTEE

MEMBERS

- Anjana Agarwal, *SEO*, Food and Nutrition, NIOS, Sector 62, Noida
- Bharti Sarkar, *Retired Associate Professor*, Maitreyi College, University of Delhi
- Bhuvan Chandra Kapri, *Professor*, Department of Physical Education, Banaras Hindu University, Banaras, Uttar Pradesh
- Ishwar V. Basavaraddy, *Director*, Morarji Desai National Institute of Yoga, Ministry of Ayush, Government of India, New Delhi
- Poonam Aggarwal, *Professor*, Department of Gender Studies, NCERT, New Delhi
- Priyanka, *Assistant Professor*, M. B. (P.G.) College, Dadri, Gautam Buddha Nagar, Greater Noida, Uttar Pradesh
- Ratnesh Singh, *Associate Professor*, Department of Physical Education, Guru Ghasidas Central University, Koni, Bilaspur, Chhattisgarh
- Sagarika Bandyopadhyay, *Dean and Head*, Department of Physical Education, Viswabharati University, Shantiniketan, West Bengal
- Shorya Kumar Yadav, *Professor*, Department of Physical Education, Devi Ahilyabai University, Indore, Madhya Pradesh
- Sima Saigal, *Assistant Professor*, North East Regional Institute of Education (NERIE) NCERT, Shillong

MEMBER COORDINATOR

- Saroj Yadav, *Professor and Dean (Academic)*, Project Coordinator of National Population Education Project (NPEP), Adolescence Education Programme (AEP), NCERT, New Delhi.

REVIEW COMMITTEE

- Anil Ramachandran, *Associate Professor*, School of Physical Education and Sports Sciences, Kannur University, Kerala
- Avinash Sidhu, *Retired Professor*, A-13 Ratan Nagar, Jabalpur
- Harish Kumar Meena, *Assistant Professor*, Department of Education in Social Sciences (DESS), NCERT, New Delhi

- Manjit Singh, *Deputy Secretary*, Physical Education and Sports, CBSE, New Delhi
- Pushkar Vohra, *Joint Secretary* (Academics), CBSE, Delhi
- Vijay Chahal, *Professor*, Department of Physical Education, Deen Dayal Upadhyay, Gorakhpur University, Gorakhpur
- Vikas Prajapati, *Assistant Director*, Department of Physical Education, The Maharaja Sayajirao, University of Baroda, Near Rosary School, Fatehgunj, Vadodara

© NCERT
not to be republished

ACKNOWLEDGEMENTS

The National Council of Educational Research and Training (NCERT) acknowledges the valuable contribution of the following individuals and organisations for reviewing and refining the manuscript of this book.

Amit Sharma, *TGT Physical Education*, Kendriya Vidyalaya No.-1, Delhi Cantt.; Asha Arora, *Science Teacher*, CIE, Department of Education, University of Delhi; Bhagwati Yadav, *Yoga Teacher*, KV NSG, Manesar, Gurugram, Haryana; Guru Dutt Ghai, *Professor*, Department of Health and Physical Education, Laxmibai Institute of Physical Education, Gwalior, Madhya Pradesh; Indu Sharma, *Assistant Professor*, Yoga, Morarji Desai National Institute of Yoga, New Delhi; Namrata Khanna, *Consultant*, Food Safety and Standards Authority of India (FSSAI), FDA Bhawan, New Delhi; Neetu Sharma, *Yoga Therapist*, Morarji Desai National Institute of Yoga, New Delhi; N.K. Dutta, *Associate Professor and Head*, Physical Education, Ichchhanath Surat, Gujarat; Preeti Shukla, *TGT Physical Education*, Kendriya Vidyalaya, Tagore Garden, New Delhi; Priti Verma, *TGT*, Physical Education, Kendriya Vidyalaya, Shivgarh, Raibareli, Uttar Pradesh; Rajveer Singh, *Teacher*, Physical Education, Jawahar Navodaya Vidyalaya, Baghra, Muzaffarnagar Uttar Pradesh; Sadhana Arya, *Former Guest Faculty*, Morarji Desai National Institute of Yoga, New Delhi; Samiran Chakrabarty, *Associate Professor*, IGIPSS, University of Delhi, B-Block, Vikas Puri, New Delhi; Shivani Bansal Moghe, *Consultant*, Food Safety and Standards Authority of India (FSSAI), New Delhi; Vikram Singh, *Professor*, Department of Physical Education & Sports, JNU, New Delhi; Abhimanyu Singh, *Professor and Head*, Department of Physical Education, Banaras Hindu University, Varanasi; Archana Chahal, *Professor*, Physical Education University of Allahabad, Prayagraj; Ashwani Bhati, D.M. School, R.I.E. Ajmer; Atul Dubey, *Faculty* of Physical Education, I.T.O., Ajmer Azad Khan, *Head*, Sportz Village Pvt. Ltd, Bangalore; Bijaya Kumar Malik, *Assistant Professor*, NCERT, New Delhi; Deepak Lakhera, DMS, RIE Bhopal; Eram S. Rao, *Associate Professor*, Department of Food Technology, Bhaskaracharya College of Applied Science, University of Delhi; Jitendra Verma, *TGT*, Health and Physical Education, Kendriya Vidyalaya Sangathan, Sec-II, Rohini, New Delhi; Kamlesh Soni, DMS, R.I.E. Bhubaneswar; Kusum Yadav, Rao Birender Singh College of Education, Rewari; Mahendra Barua, *T.G.T.*, Physical Education, R.I.E. Bhopal; Ravipal Singh, K.V.S. Shakurbasti (KVS), Delhi;

Sujit Panigrahi, *Founder and C.E.O.*, Education Startup Fitness
365, Sohna Road, Gurugram, Haryana;

We acknowledge the contribution of Blue Fish Designs Pvt. Ltd. for making the illustrations for this textbook, Azra Khatoon, Shefali Sharma, and Aakansha, *Junior Project Fellow*, NCERT, New Delhi for going through the material, Rani Sharma (*PA*) for creating a CRC, Mohd. Kashif, Ruby Malik and Ravi Sharma for typing the material and Bittoo, *D.T.P. Operator* for laying out the text. The contributions of Soumma Chandra, *Assistant Editor* (Contractual), and Rajshree Saini, *DTP Operator* (Contractual) are also acknowledged for editing and preparing the layout this book.

The Council gratefully acknowledges the valuable suggestions and feedback received during try-out by teachers.

© NCERT
not to be republished

HOW TO USE THIS BOOK

It is expected that the transaction of this book titled *Health and Physical Education* for Class X will enable the teachers and students to transform theoretical knowledge into action. Further the teachers will be empowered to bring out the positive change through modification during learning and practicing various games and sports among students. In schools, where infrastructural facilities are not available, the teacher may improvise them with the help of students like playground, equipments, rules of the games, etc. This will also develop creativity among children. Playing games and sports in all conditions important for holistic health.

The book contains 13 chapters. The first chapter deals with Physical Education and its relationship with other subjects. The second chapter explains the effects of physical activities on human body. The third chapter discusses the issues related to growth and development during adolescence. Chapters 4, 5, 6, and 7 discuss the details of individual and team games.

Efforts have been made to include latest rules and regulations of various games and sports and other related areas. Since the rules and regulations keep on changing, teachers and students may visit the official website of the recognised Federation or Association of the different games and sports. The names of some websites are given separately. The teachers and students may also see some of the videos of different games and sports given in the official websites related to a particular federation for understanding the rules and learning the skills.

Yoga for Healthy Living is the eighth chapter. Chapter 9 explains dietary considerations and food quality. Safety for healthy living, healthy community living and social health are discussed in Chapters 10, 11 and 12 respectively. The last chapter provides details about the agencies and awards promoting health, sport and yoga.

The book also includes information about corona virus, more specifically known as COVID-19 causing massive loss of human lives and creating panic across the world. It is important to prevent and deal with this challenge and to empower the younger generation to face this challenge. The book has provided links as well as, added the relevant information at suitable places.

The overall objective of this book is to make games and sports joyfull and thereby making childern physically fit, mentally alert and emotionally strong. The teacher may also encourage to select games or sports of their choice by maintaining social distancing

for practical experience. Yogic practices need to be more focussed and considered as an integral part of their everyday life in the present context.

The teacher should also emphasise on developing life skills, such as, understanding self, social awareness, team building, cooperation, empathy, communication skill, creative thinking and also development of values.

The students can correlate the given activities in the textbook with their day-to-day life.

As a teacher, you have to understand that this textbook is different from other subject textbooks in the sense that its contents need to be understood well and applied throughout life for one's own well being and that of others. Its use should not, therefore, be solely examination driven. Even a general discussion from time to time would be useful. Activities included in it, are of practical nature and enjoyable and one can make sure that the concepts are clarified by involving students in experiential learning. Physical activities and exercises of all kinds have been given to ensure the development of fitness and questioning skills, including life skills.

We would welcome your feedback on this book in terms of — How did you like this textbook? What are your experiences in organising or being a part of various activities? What were the difficulties faced by you? What changes would you like to see in the next version of this book? Do write to us on all these and other matters related to this textbook. You could be a parent, a teacher, a student or just a casual reader. You can send your feedback in the form given at the end of this book to the undersigned.

We sincerely hope you enjoy this book and learn more than it offers.

New Delhi
May 2020

Saroj Yadav
Professor and Dean (Academic)
National Council of Educational
Research and Training

CONTENTS

<i>Foreword</i>	<i>iii</i>
<i>How to use this book</i>	<i>ix</i>
Chapter 1 Physical Education: Relation with other Subjects	1 - 10
Chapter 2 Effects of Physical Activities on Human Body.....	11 - 22
Chapter 3 Growth and Development during Adolescence	23 - 34
Chapter 4 Individual Games and Sports I.....	35 - 51
Chapter 5 Individual Games and Sports II.....	52 - 76
Chapter 6 Team Games and Sports I.....	77 - 110
Chapter 7 Team Games and Sports II.....	111 - 132
Chapter 8 Yoga for Healthy Living	133 - 164
Chapter 9 Dietary Considerations and Food Quality	165 - 180
Chapter 10 Safety Measures for Healthy Living	181 - 192
Chapter 11 Healthy Community Living.....	193 - 204
Chapter 12 Social Health	205 - 214
Chapter 13 Agencies and Awards Promoting Health, Sports and Yoga	215 - 223

LIST OF USEFUL WEBSITES

Note: Please refer to the home websites of the recognised federations of the various sports for updated information about rules and regulations.

- <https://www.ioc.org>
- <https://www.arisf.sports>
- <https://www.iaaf.org> (Athletics)
- <https://www.BWFBadminton.org> (Badminton)
- <https://www.fiba.basketball> (Basketball)
- <https://www.fifa.com> (Football)
- <https://www.gymnastics.sports> (Gymnastics)
- <https://www.IHF.info> (Handball)
- <https://www.Fih.ch> (Hockey)
- <https://www.ijf.org> (Judo)
- <https://www.fina.org> (Swimming)
- <https://www.ittf.com> (Table Tennis)
- <https://www.itftennis.com> (Tennis)
- <https://www.fivb.com> (Volleyball)
- <https://www.unitedworldwrestling.org> (Wrestling)
- <https://www.mohfw.gov.in>
- <https://main.mohfw.gov.in/sites/default/files/schooladvisory.pdf>

Note: For updation of every game and sport, you can consult or refer to rule books of various sport's federations.

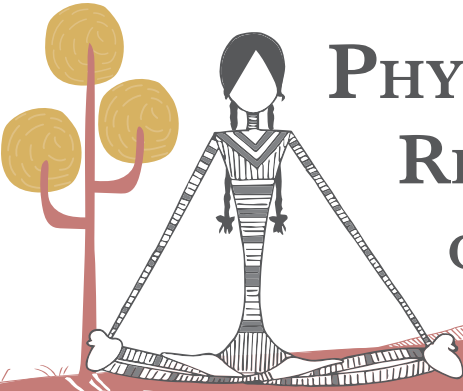

PHYSICAL EDUCATION: RELATIONSHIP WITH OTHER SUBJECTS



Physical education (PE) aims at the optimum development of an individual through continuous process of learning and participation in guided physical activities. In other words, it aims at optimum physical, mental and social development of an individual.



1077CH01

WHAT IS PHYSICAL EDUCATION?

According to Webster's Dictionary, "Physical education is a part of education which gives instructions in the development and care of the body rendering from simple callisthenic exercises to a course of study providing training in hygiene, gymnastics, and the performance and management of athletics and games." Central Advisory Board of Physical Education and Recreation defines PE as "an education through physical activities for the development of total personality of the child to its fullness and perfection in body, mind and spirit. Physical education is an area through which sports, outdoor activities like trekking, hiking, camping, gymnastics, dance, aquatics are used to train individuals in motor skills and fitness skills. Physical education also assists the schools in carrying out responsibility of developing personal and social skills in students." In fact, PE is an integral part of total education. It makes significant contribution towards the achievement of desirable educational and health outcomes. It also enables children to acquire necessary knowledge and skills to stimulate them to actively participate in physical activities throughout their lifespan.

NEED AND IMPORTANCE OF PHYSICAL EDUCATION

Participation in games, sports and yoga provide thrill and enjoyment to everyone. In addition, it helps to entertain and maintain a healthy lifestyle.

Healthy lifestyle

By engaging in various physical and yogic activities, one can ensure a healthy lifestyle.

Academic achievement

By participating in various physical and yogic activities, students get stimulated to face challenges and are encouraged to think productively. This tends to improve their concentration of academic achievement.

Develops skills and experiences

Various activities learned during school days such as gymnastics, running, jumping, throwing, swimming, playing team games, learning the rules and regulations of the games and being disciplined help students to develop sportspersonship.

Positive self-image

Participation in regular physical activities also helps students to understand the need for appreciation of own positive aspects and develop ability to compete and cooperate with others. Self belief is also reinforced.

Activity 1.1

- Measure your pulse and respiration rates before and after playing different games or participation in a sport event.
- Collect information from 10 persons and prepare a project on physical activities and eating habits and their impact on the human body.

Improves interpersonal relationships

When you play with other students and teams, you learn to develop interpersonal relationships with members of your own team as well as with members of other teams. It builds interactive and positive social environment.

Develops internal organ systems

By participating in physical and yogic activities, students respond to the increased demands of daily life in a healthy way. The system of the body responds to stimuli and becomes more efficient at coping with the load exerted on it.

2

OBJECTIVES OF PHYSICAL EDUCATION

Broadly, there are four objectives of Physical Education which are as follows.

Physical fitness

It refers to the state where an individual is physically fit and has developed great endurance, speed and strength. Physical fitness is essential for leading a happy, healthy, vigorous and fulfilling life. Physical and motor fitness helps to learn and develop technical and tactical knowledge of sports and games.

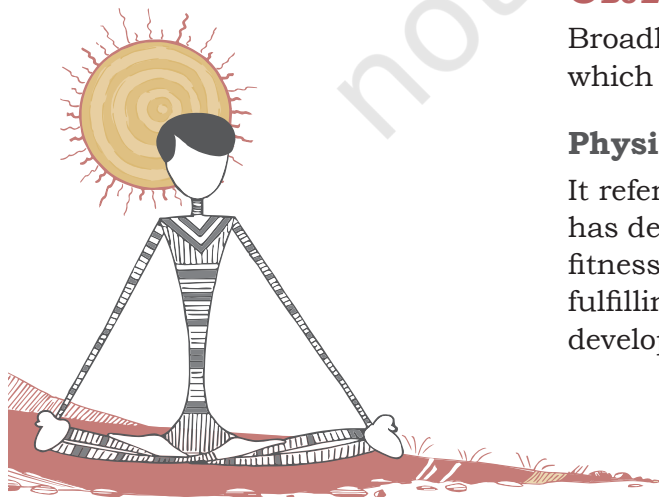

Social efficiency

It is concerned with one's adaptation to group living. Physical education activities provide ample opportunities to develop such traits and life skills as cooperation, respect for others, loyalty, sportsmanship, self-confidence, etc. All these qualities help a person to become more social and a responsible citizen.

Sports culture

It aims at developing an understanding and appreciation of one's own local environment as well as the global environment. By participating in various physical activities, such as, dance, sports, games and yoga, a person fully understands the history, culture, traditions, etc., and also the aesthetic values associated with these activities.

Mental efficiency

In physical education, a child has to participate in a number of physical and yogic activities. These activities not only require involvement of the body but also require use of the intellect to carry out the task. Positive, healthy and active body-mind relationship helps to enhance mental efficiency.

SCOPE OF PHYSICAL EDUCATION

Physical education has evolved as a multi-disciplinary subject and its scope is not just confined to physical fitness and the rules of games and sports. The meaning and definition of Physical Education, its aims and objectives and scope, and factors affecting physical fitness and wellness, rules and other necessary knowledge about health, games and sports and yoga are major areas of study in physical education. Games and sports, as well as, cultural heritage, development of leadership qualities and group dynamics through sports and games are also an integral part of this discipline.

In fact, physical education now includes several areas which belong to other subjects like Biology, Genetics, Psychology, Physics, Bio Chemistry, Sociology, Anthropology, History, Culture, Medicine, Media studies, etc.

Contents from other disciplines like laws of motion, types of lever, force, equilibrium and centre of gravity, common postural deviations, therapeutic modalities in rehabilitation, sports massage, prevention and first aid for common sport-injuries, are also the content of physical education. Biological foundations such as heredity and environment, growth and development are also included in it.

Content drawn from psychology, such as, importance of psychology in education with special reference to physical education, such as, individual differences and personality, learning and motivation are related to Physical Education.

Activity 1.2

- List responsibilities as an individual and in teams while playing the game of your choice.
- Discuss leadership skills in class developed through health and physical education sessions.

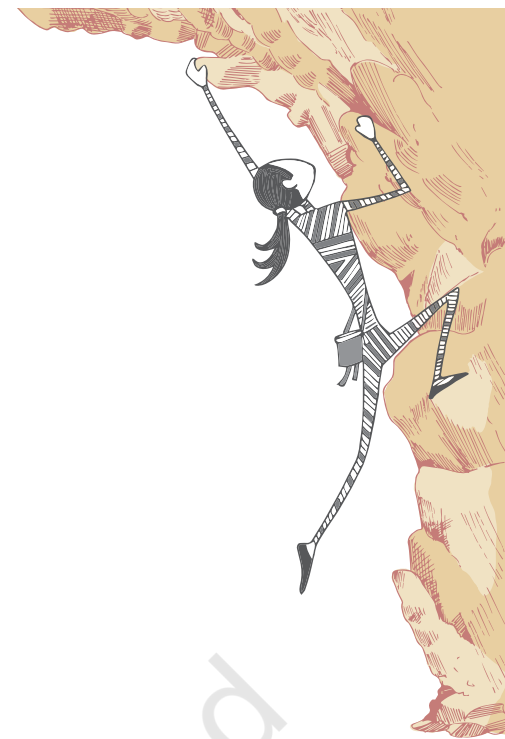

Personality means, nature and factors affecting performance and transfer of training constitute one of its major components. Similarly, contents related to basic physiology, anatomy, growth and development during adolescence also form part of the content of physical education. Some other contents are organ system, functions of bones, definitions and classification of joints, movement around a joint, general characteristics (properties) of muscles, effects of exercise on muscular system, circulatory system, respiratory system and digestive system, health dimensions, environment, importance of health, health problems, hygiene, community health, aspects of school health services, food, nutrition and balanced diet, communicable and non-communicable diseases, coronavirus, HIV, AIDS and drug abuse.

1. What is Coronavirus?

Covid 19 is the infectious disease caused by the recently discovered coronavirus. This new virus and disease were unknown before the outbreak began in Wuhan, China, in December 2019. That is why it is called the Novel (new) Coronavirus (NCoV).

2. What are the symptoms?

The most common symptoms of Coronavirus are fever, cough and difficulty in breathing. Some patients may have aches and pains, nasal congestion, runny nose, sore throat or diarrhea. These symptoms are usually mild and begin gradually. Some people become infected but don't develop any symptoms and don't feel unwell. Most people (about 80%) recover from the disease without needing special treatment. People with fever, cough and difficulty in breathing should seek medical attention immediately.

3. How does Coronavirus spread?

People can catch Coronavirus from others who have the virus. The disease can spread from person to person through small droplets from the nose or mouth which are spread when a person with Coronavirus coughs or exhales. These droplets land on objects and surfaces around the person. Other people then catch Coronavirus by first touching these objects or surfaces, then touching their eyes, nose or mouth. People can also catch Coronavirus if they breathe in from a person with Coronavirus who coughs out or exhales droplets. This is why it is important to stay more than 1 meter away from a person who is sick.

4. How to prevent Coronavirus?



Wash your hands with soap water regularly.



Throw used tissues into closed bins immediately after use.



If soap and water is not available, use hand sanitiser with at least 60 per cent alcohol.



Cover your nose and mouth with handkerchief/tissue while sneezing and coughing.



Wash hands before touching eyes, nose and mouth.



Avoid mass gathering and crowded places.

For more information, refer to —

https://www.mohfw.gov.in/pdf/FacilitatorGuideCOVID19_27%20March.pdf

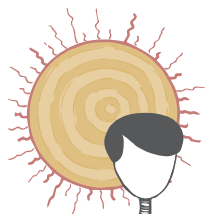

Contents related to Yoga also form a part of this area. Common Yogic Practices are *Yama* and *Niyama*, *Asana*, *Pranayama*, *Pratyahara*, *Bandha Mudra*, *Shatkarma/Kriya*, Meditation. It includes *Ahara* (Food), *Vihara* (Relaxation), *Achara* (Conduct), *Vichara* (Thinking), *Vyavahara* (Behaviour).

Theories of training are also included in this subject area. These are principles and characteristics of sports training, methods of sports training, training load, warming up, cooling down, aerobic and anaerobic activities, calisthenics and rhythmic exercises, specific training program for development of various motor qualities, techniques, tactics and talent identification. It is also important to understand the difference between play, games and sports.

PLAY, GAMES AND SPORT

Though these terms are used interchangeably, these are actually different.

Play

Play is spontaneous. It is usually a creative activity but has its own limitation and space. One plays voluntarily for fun and pleasure. Play, however, is a broad area which includes both games and sports. The distinctive features of play are that they are free, separate, uncertain, governed by self rules and creative.

Games

Generally the word games and sports are used together. A game is an activity involving more players, defined by a goal that the players tries to reach, and some set rules to play. By masses, games are played primarily for entertainment or enjoyment. The difference of purpose differentiates sport from game, combined with the notion of individual or team skill. Games are also played on the basis of a set of rules. A game is defined as a goal that the players try to achieve. A person who participates in a game is known as a player.

Sport

A sport is a physical activity carried out under an agreed set of rules, for competition or self-enjoyment or a combination of these. Sport are the kind of activities in which similar kind of body movement is repeated over a long time. For example, swimming and running and almost all the track and field events come under sport. Sport involves an activity or activities where the mental capabilities of the sportsperson are judged. In a sport, it is the sportsperson or the individual who determines the outcome. A person participating in a sport is called an athlete or a sportsperson.

Activity 1.3

The teacher divides students into small groups of 10 and plans an aerobic dance or drama. Keeping in view the skill, creativity, and music, these may even be in the form of a competition.

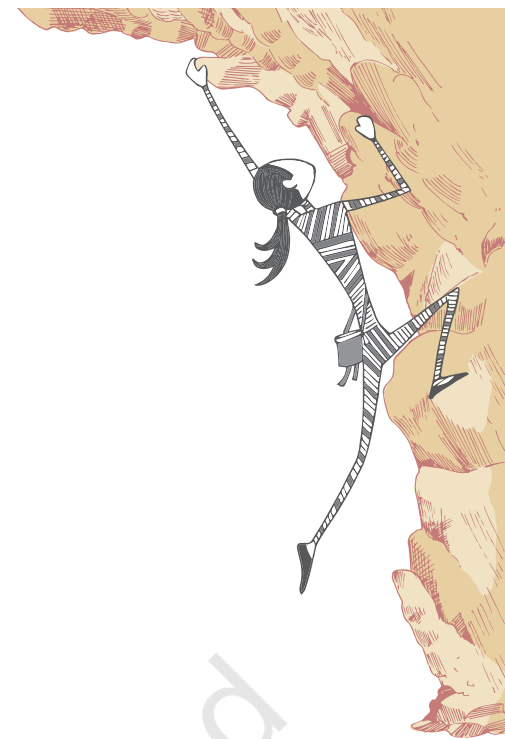

RELATIONSHIP OF HEALTH AND PHYSICAL EDUCATION WITH OTHER DISCIPLINES OF KNOWLEDGE

Health and Physical Education (HPE) classes provide space for exploring new ideas related to personal and community health. These ideas might then be used by students in various other fields of learning, such as, arts, science, civics and citizenship, communication, design, creativity and technology and languages (english, hindi and other regional languages), humanities (e.g. history, geography, economics, etc.), information and communication technology and psychology.

Art

Health and physical education teachers can incorporate activities related to performing arts, drawing, painting, dance, drama, media, music and visual communication into their programs. These involve both fine motor skills and whole body movement including rhythmic movement. As body movements are part of both arts practice and health and physical education, these promote health knowledge, understanding of the body and lead to physical fitness and enhancing of creative skills at the same time.

Science

The human body is a common concern of both science and health and physical education. In science, students study the human body from the cellular level to the systems level, with a focus on anatomy and physiology. In health and physical education learning is focused on the requirements for good health and the promotion of a healthy body. Students gain an understanding of the role of physical and yogic activities in ensuring good health and can link the functioning of the musculo-skeletal, digestive, endocrine and nervous systems studied in science, for the promotion of the physical, social, mental and emotional health of individuals within a society. Students consider it their personal responsibilities to discuss and adopt health issues, both in relation to their own safety and well-being, as well as to the safety and well-being of others. It also contributes in the designing of training for movements of organs to achieve optimal performance in the area of play, sports and games.

Social science

Social sciences promote the idea that citizens require knowledge and understanding of civic institutions and the skills and willingness to actively participate in functioning of the society. Similarly, in health and physical education,



students are encouraged to become active and responsible members of their community. Key concepts within health and physical education classes include understanding of the importance of personal identity within a community, what makes a community and how to engage with different members and agencies within a community. Participation in physical activity and sports also reflect values, rules, rights and responsibilities indicative of a democratic society.

Communication

Communication involves developing knowledge, skills and behaviors that empower students to respond to, make meaning of, and deconstruct a range of communication forms. Effective communication is a key skill in health and physical education. It is essential that students develop the ability to listen, view and respond with respect to the content and context in which communication happens. Learning in the health and physical education domain involves developing familiarity with forms, language and conventions used in different forms of public, personal and interpersonal communication.

Design, Creativity and Technology

Design, Creativity and Technology (DCT) help in developing sport goods, sportswear, sport software programme, etc. These are associated with knowledge and promotion. In this area students learn about the characteristic and properties of how all these aspects differ from each other. These investigations assist students to make decisions about appropriate solution. Students analyse and evaluate factors, such as, social, cultural and economic factors that influence design, creativity and technology.

Language(s)

Languages help students to develop critical approaches to the ideas and thoughts collated to read, view, write, compare, research and talk about texts. Health and Physical Education teachers can use examples related to health and wellbeing to encourage students to reflect on their lifestyles and analyse ways by which the media influences their attitude towards health. For example, Health and Physical Education emphasises on the importance of physical fitness, self-esteem and body image in the maintenance of good health.

Economics

Economics is the study of how society allocates scarce resources to satisfy the wants and needs of its members. Within the health and physical education (HPE) context, consumer health assists students to become more informed consumers of health products and services.

Activity 1.4

- Identify and analyse health needs and services available in the community.
- Investigate the cost of specific behaviours, illness or disease in the community, such as, the economic impact of obesity and inactivity on society.
- Explore the influence of government spending on health outcomes for individuals and the community.
- Identify various locations from the map and interpret maps for outdoor adventure activities.
- Investigate the impact of development and globalisation on poverty, the links between food, hunger and technology, identifying and locating facilities and services that contribute to the health and safety of communities on a local and national level.



Activity 1.5

- Create a report and may be a presentation about a game of your choice.
- Capture still and moving images of sporting activities organised in your school and edit or annotate them to explain skill development or tactics.
- Identify, collect and evaluate data from online sources such as, blogs, websites and forums to inform about myths related to Physical Education.

The cost of disease emerging from unhealthy lifestyle is also studied to determine the burden of disease on families and community.

Geography

Students develop skills in reading and interpreting maps of different kinds and at different scales. The same knowledge and skills are reinforced in physical education during orientation on outdoor education activities (Trekking, Mountaineering, etc). The investigation of local and global health issues involves collecting information from maps, satellite images, statistical data and information and communication technology based resources. These help students to understand themselves and their world, to apply their understanding in their present lives as well as make evidence based decisions that lead to the kind of future they desire.

History

The study of History reflects multiple influences and connections to an array of other countries, cultures and times. The concepts of time, chronology and changes are common to both History and Health and Physical Education. While History focuses on identity from a cultural or national perspective, Health and Physical Education focuses on the range of factors that shape personal identity.

Like skill correction analysis programme, use of cameras and videos in game, use of wind gauge, Iso kinetic machines, construction and marking of play field.

Information and Communications Technology (ICT)

ICT can be used to access, process, manage and present information and events. It constructs new understanding and communicate with others. It is an integral part of different training measurement and evaluation and of course coaching and officiating very helpful in conducting tournament.

Mathematics

In Health and Physical Education, Mathematics provides tools and procedures which can be used to model situations and solve problems in areas, such as, scoring different sporting events involving time, distance, weight and number as variables, calculating percentage improvement in results from data collected through fitness testing or performance in physical activities.

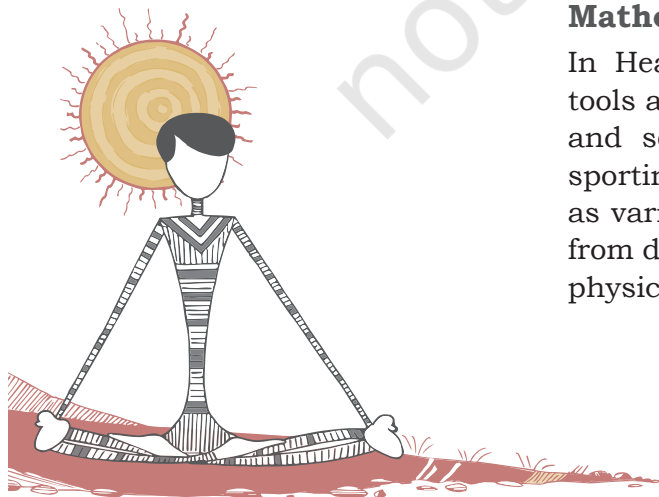

Language other than English (LOTE)

There are a number of martial arts developed by different societies. The text of these martial arts is discussed in the local languages. For folk dances the accompanying songs are in regional languages and music has its own characteristic tone and rhythm.

The concepts of movement, dance, physical activity and sport, vary culturally. These are associated with their own specific languages, vocabularies and discourses. Different societies have different attitudes, values and beliefs about physical activities which are expressed in their regional languages.

MYTHS AND MISCONCEPTIONS ABOUT PHYSICAL EDUCATION

Myths are surrounded in regard to relationship of physical education with academic success. One of the most discussed myths in the society is that participation in sport and games reduces academic performance of individual.

Myths

Participation in sport kills the time of study. Contrary to the widely held assumption that sport and other activities cut upon the time for serious school study, research evidence has shown that students tend to do better in school when they participate in physical activities. There is a positive correlation between performance in sport and the level of academic achievement. Physical education including sport is an integral part of the social and cultural infrastructure of a nation. It really can make a difference in the broader educational process and in changing and enhancing the quality of life. Vigorous physical exercise stimulates circulation, helps prevent skin eruptions and increases fluid intake. These exercises also promote self-worth and mental health, and support an individual for healing an injury. Sport also enhances physical performance and induce positive physiological adaptation. When children exercise, their fitness needs are met, and build up energy to learn and achieve. Given the growing number of children with obesity, watching TV, continuously being involved in computer games and other unwanted activities, frequency of the children getting involved in physical achievement and academic performance, has taken a back seat. Physical exercise enhances the function in joints, increases the sense of physical well being and promotes a sense of feeling good. It also increases physical working capacity by increasing cardio-respiratory fitness and increased strength and endurance and decreases risk of serious disease that could lead to early disability and death.

Activity 1.6

- Identify, collect and evaluate data from online sources, such as, blogs, websites and forums to inform about myths related to Physical Education.



ASSESSMENT

I. Answer in Brief

1. What do you mean by physical education?
2. What is the contribution of science subjects to physical education?
3. "Although physical education uses content from several disciplines, it is fast emerging as a discipline." Write two arguments favouring this statement.
 - (a) _____
 - (b) _____
4. Who is a physically fit person?

II. Short Answer Questions

1. Should physical education and sports be an integral part of learning? Justify your answer. Give at least three reasons.
2. "All sports can be games, but not all games can be sports" Give at least two arguments for or against the statement.
 - (a) _____
 - (b) _____

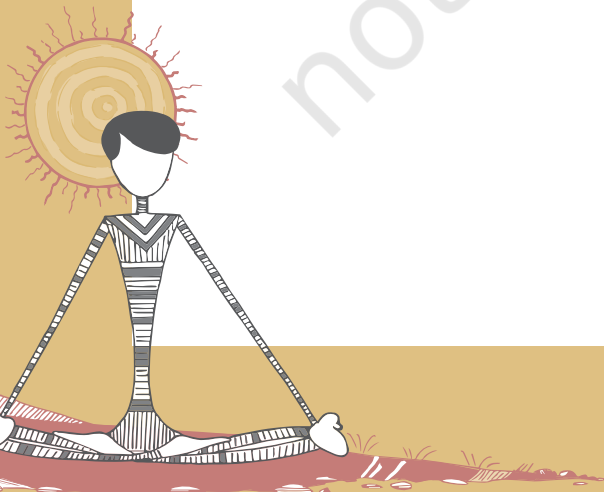



EFFECTS OF PHYSICAL ACTIVITIES ON HUMAN BODY



In this chapter, we shall discuss the effects, both short-term and long-term, of physical activity on each of the major organ systems of human body. You are aware that a healthy individual is one who has a healthy mind in a healthy body. This state of health can be achieved when various organ systems of the body function in harmony. For example, physical activities are based on motor movements and their co-ordination. The command for movements comes from the brain which is a part of the nervous system. The required energy for movements and other activities is obtained from food. Food is completely digested in the intestine, a part of digestive system. Food and oxygen reach all the parts of body through the action of heart, which is a part of the circulatory system. In fact, many organ systems of the body function as an integrated whole for healthy maintenance of the body.

You have already studied about organ systems of the human body in the previous science classes. In this chapter, the organ systems have been discussed in relation to the effect of physical activities. It is a common experience that performance in any event, sports or otherwise, depends upon physical health, as well as, mental and emotional health. Development and maintenance of physical, mental and emotional health specially during this coronavirus (COVID-19) is therefore, very important.

ORGAN SYSTEMS OF HUMAN BODY

Aggregates of cells constitute a tissue. Tissues of various kinds together make an organ and many organs together comprise an organ system. Various organ systems perform different functions of the body necessary for wellbeing and healthy living. The organs which have a major role to play in the functioning of their respective system, such as, heart, lungs, liver and kidney



1077CH02

are called vital organs. Before we learn about the impact of physical activities on organ systems, let us review functioning of these systems.

Organ systems for movement of body and limbs: skeletal and muscular systems

When you walk, play, exercise, practice or participate in a sport, or even when you 'warm up' prior to a sport activity or competition, what is most obvious are the movements of hands and legs, with the brain being equally active. All the movements are due to contraction of muscles. Muscles are attached to bones. Bones form the skeleton. Bones are attached to each other by ligaments and muscles are attached to bones by tendons (Fig. 2.1, 2.2, 2.3).



Fig. 2.1: Muscle movement

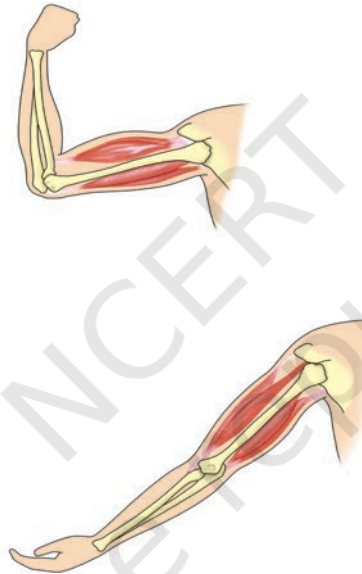

Fig. 2.2: Muscle of the arm

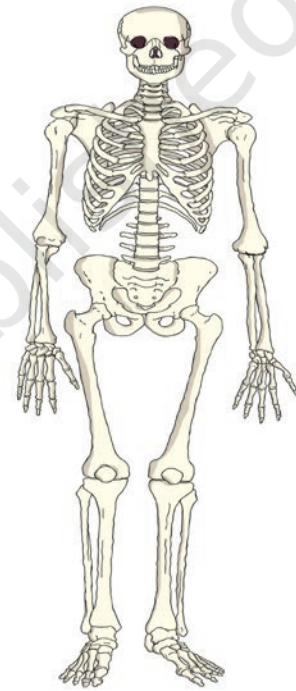
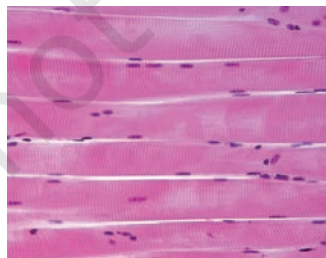
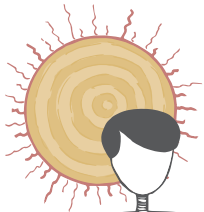
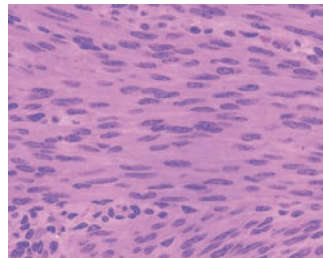

Fig. 2.3: Human skeleton

12



Skeletal muscle



Smooth muscle

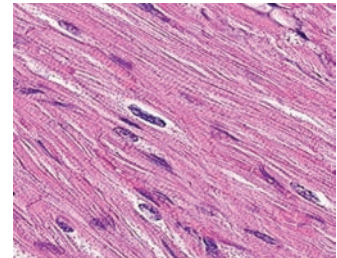

Cardiac muscle

Fig. 2.4: Types of muscles

Muscles are made up of muscle cells which are also termed as muscle fibres because of their elongated shape. You have learnt in earlier classes that there are mainly three kinds of muscles. There are muscles that contract to cause movements according to one's will. These are called voluntary muscles, such as, those of the limbs and the neck. The involuntary muscles, such as, those lining the food canal, move automatically without our efforts for making them move. Another kind of muscles, which are also involuntary, are the muscles of the heart or cardiac muscles which never stop contracting and relaxing. As learnt in earlier classes, muscle cells (muscle fibres) may be striated (voluntary) muscle fibres, unstriated (involuntary) muscle fibres and cardiac muscle fibres (Fig.2.4). Muscles are grouped into bundles enclosed in a membrane. Movement of muscles takes place by the movement of molecules of muscle proteins, called actin and myosin present in the muscle fibres. Upon receiving instructions from the brain and nerves, these proteins slide over each other and the muscle contracts. Muscle contraction uses up energy, which comes from food. It is measured in calories.

Energy producing organ systems

Through digestive system, food gets digested and converted to a form, which can be broken down in the cell to release energy. Respiratory system ensures a continuous supply of Oxygen to each and every cell of the body for oxidation of food. It is also responsible for continuous elimination of carbon dioxide produced as a result of this oxidation.

Digested food (Glucose) + Oxygen → Carbon dioxide + Water + ATP

Adenosine Tri Phosphate (ATP) is the chemical that releases energy. ATP is biological energy.

Respiratory system functions to ensure the continuous supply of oxygen to the body and removal of carbon dioxide from the body. Fig. 2.5 shows the different parts of the respiratory system. The intake of oxygen laden air from the atmosphere into lungs is inspiration (inhalation) and the process of removal of CO₂ laden air from lungs is expiration (exhalation). Inspiration and expiration constitute breathing. (Fig. 2.7)

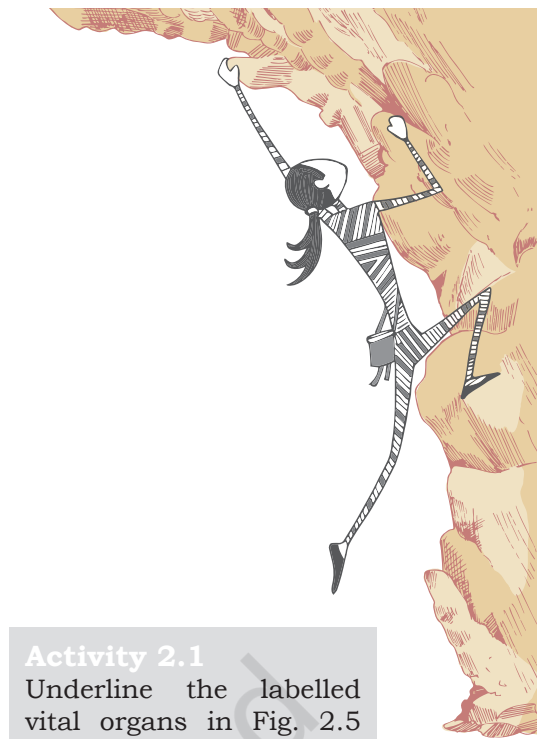

Activity 2.1
Underline the labelled vital organs in Fig. 2.5
Observe the location of the vital organs such as the spinal cord.

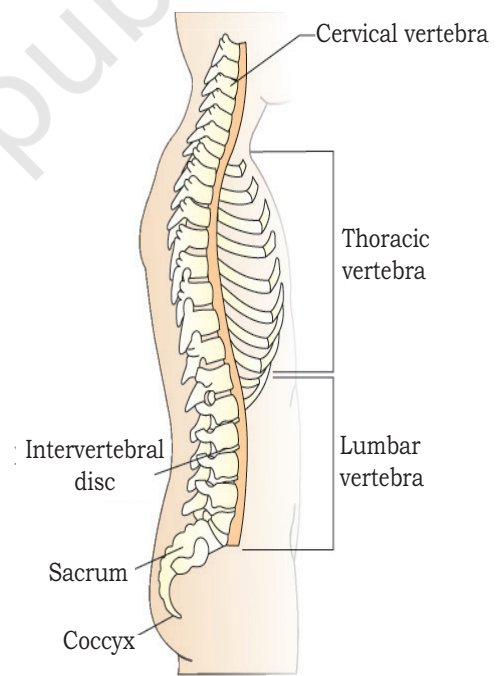

Fig. 2.5: Respiratory system

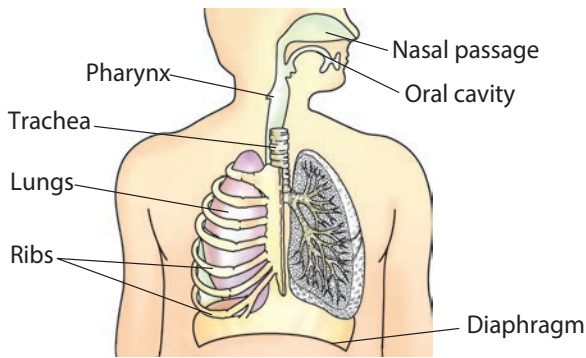

Fig. 2.6: Human respiratory system

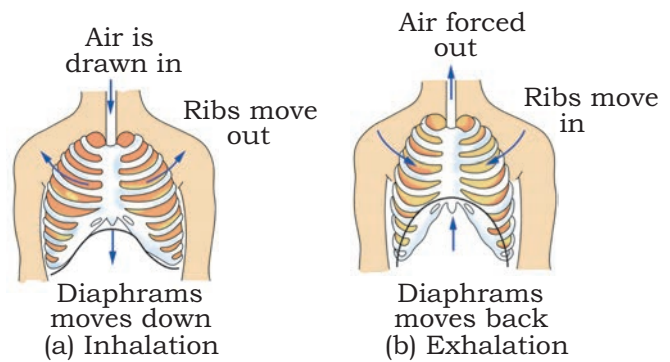

Fig. 2.7: Mechanism of breathing in human beings

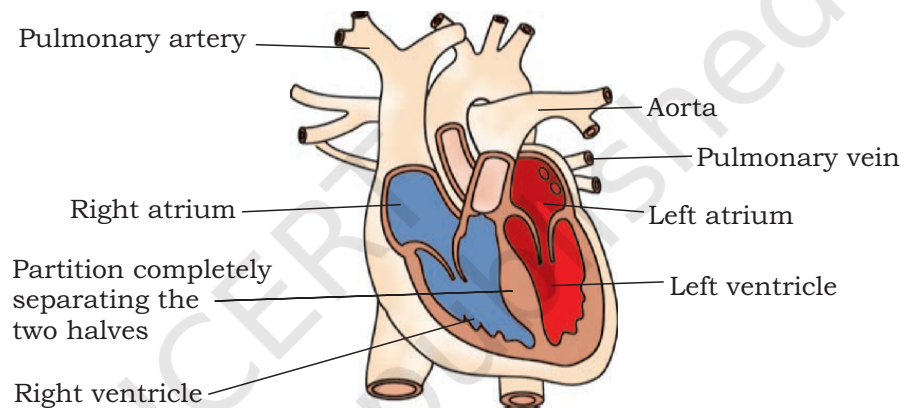
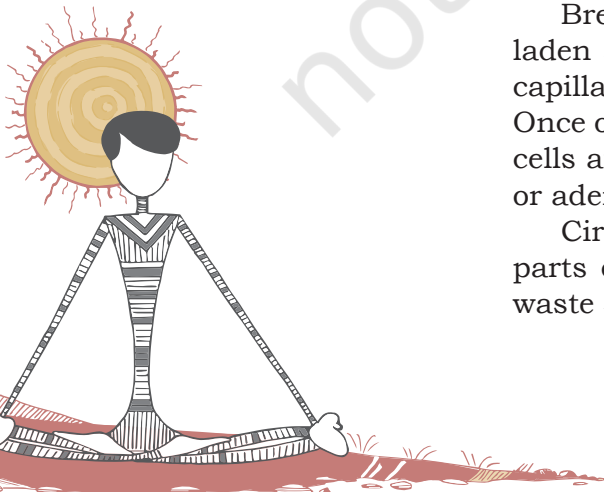

Fig. 2.8: Human heart

You have already learnt in earlier classes that when muscles of rib cage and diaphragm (the muscular partition between thorax and abdomen) contract and flatten, the thoracic cavity increases in volume and air from outside rushes in. It passes through nostrils, pharynx, trachea and bronchi and reaches the lungs (inhalation). The reverse happens during exhalation when muscles of the rib cage and diaphragm relax and CO_2 laden air from lungs goes out through bronchi, trachea and nostrils.

Breathing is followed by internal respiration when oxygen laden air from alveoli or air sacks of lungs is picked up by capillaries and reaches the heart through pulmonary vein. Once oxygen reaches cells, it oxidises glucose (which reaches cells after digestion through blood) to release energy as ATP or adenosine tri phosphate.

Circulatory system circulates nutrients and oxygen to all parts of the body. It also carries carbon dioxide and other waste substances produced in the body to organs (lungs and



kidneys) for their removal. It also transports hormones and minerals required for the body.

The flow chart below shows organs of circulatory system for you to recall.

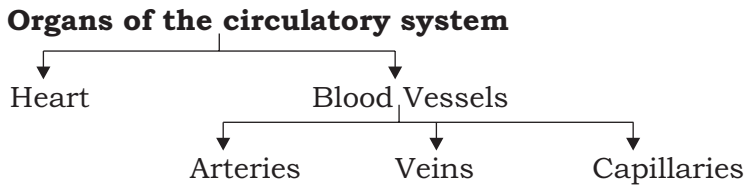

Heart (Fig. 2.8) is the most vital organ of the body. It is situated between the two lungs in the thoracic cavity and is a cone shaped muscular, four chambered organ covered by a membrane. The four chambers are left and right atria (singular atrium) and left and right ventricles. They are separated by muscular partitions called septa singular septum. The chambers communicate by openings which are protected by valves.

The cardiac muscle cells continuously contract and relax (heart beat) for pumping blood into the organs and receiving blood from them. As the heart beats, oxygenated blood flows into the arteries and goes to various parts of the body, and then it flows back to the heart through veins for oxygenation in the lungs. This circulation of blood is depicted below. Blood flow between heart and lungs is called pulmonary circulation, while between heart and body parts is called systemic circulation.

The process of circulation is shown in Fig 2.10 and further elaborated below.

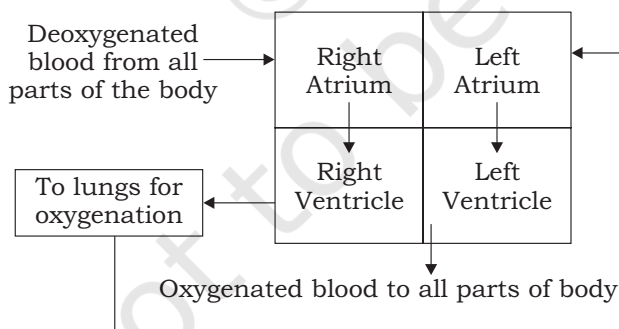
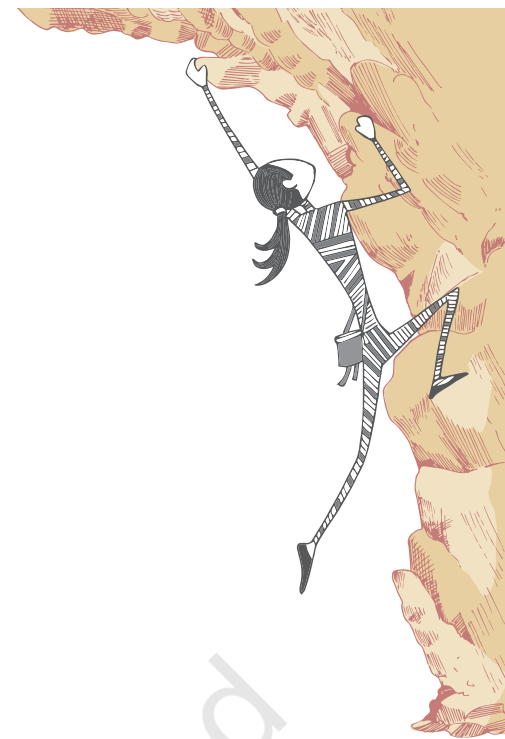

Fig. 2.9: Diagrammatic representation of the heart and the flow of blood through it

As shown in the above figure

- Deoxygenated blood from all parts of the body is collected by the veins. Veins pour deoxygenated blood laden with carbon dioxide into right atrium of the heart.



- From right atrium, deoxygenated blood goes to right ventricle and then through pulmonary artery to lungs.
- Pulmonary vein carries (oxygenated blood) from the lungs to the left atrium of the heart from where it goes to the left ventricle.
- Aorta, a large artery arises from left ventricle and the oxygenated blood enters the arteries and reaches all the organs through them.

Activity 2.2

In the diagram below, fill in the blanks with the words provided within brackets. In the upper boxes name the parts of the body from where blood is entering or going to and in the lower box state the kind of blood, oxygenated or deoxygenated. After filling discuss with one of your classmates.

[Words: Lungs, upper part of body, lower part of body, all parts of body; +O₂ (oxygenated) and -O₂ (deoxygenated).]

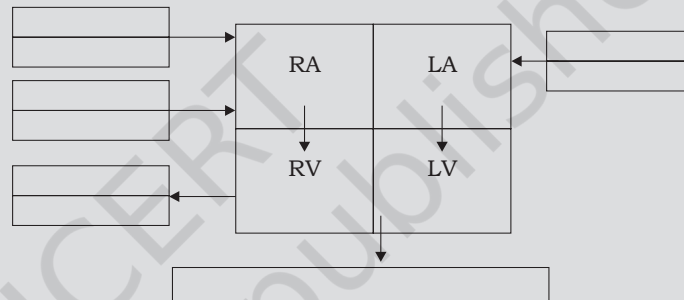

Now you have understood that blood flows from various parts of the body to heart, heart to lungs, lungs to heart and heart to various parts of the body. Since, in one circuit of circulation, blood passes through the heart twice, blood circulation is termed double circulation. Regular physical exercise has a positive effect on circulation. Hence, regular physical exercise is important for all.

EFFECTS OF PHYSICAL ACTIVITIES, GAMES, SPORTS AND YOGA ON MUSCULAR, CIRCULATORY AND RESPIRATORY SYSTEMS

Physical exercise and Yoga, when regularly done, have a positive effect on the body, as explained below.

Effects of physical activities on vital organs and body functions

Bones

Weight bearing exercise helps preserve bone mass and thus protects against osteoporosis (bone degeneration).

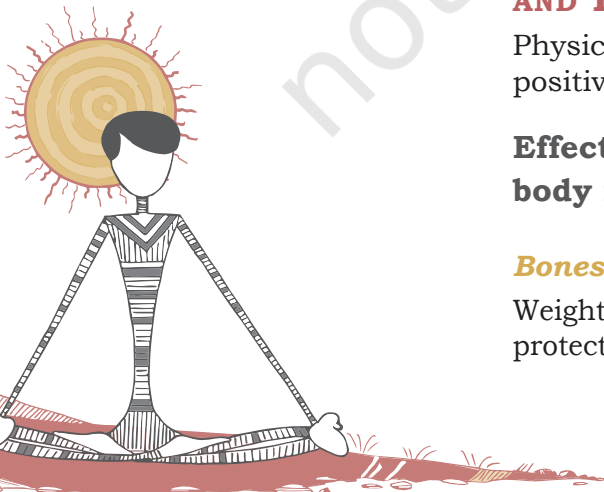

Muscles

Physical activity build and strengthen muscles, which can protect the bones from injury, support and protect joints from being affected by arthritis. Strong muscles also give stability and improve balance and coordination during movements. Physical activities also improve blood supply to the muscles and increase their capacity to use oxygen.

Muscles and muscle performance

Physical activities if undertaken regularly have beneficial effects on the muscular system. Whenever physical activities, games or sport are undertaken there is contraction of muscles and increase in energy level due to breakdown of ATP.

The beneficial effects of regular physical activities are listed below —

- *Change in shape and size of the muscle fibres:* Muscle fibres enlarge with physical activities which cause an overall enlargement of muscles with the change in its size and shape. The size of muscles increases by 60 per cent. It is because of this reason that, the muscles of arms of a tennis player are well developed.
- *Maintenance of muscle tone:* Muscles are stimulated to contract by signals from nerves. Due to continuous signals, when physical exercises are undertaken, muscles remain in partial state of contraction called muscle tone. Hence, regular physical activities maintain good muscle tone and enhance physical fitness.
- *Increase in muscle proteins:* The units of muscle contraction are proteins. Physical activities lead to increase in total proteins.
- *Increase in blood capillaries:* Regular physical exercises lead to increase in number of blood capillaries supplying blood to muscles.
- *Increase in efficiency of ligaments and tendons:* Ligaments and tendons become more efficient as a result of regular physical activity. This improves muscle movements resulting in greater tolerance of stress during strenuous activity.
- *Long term increase in muscle strength:* Regular physical exercises increase and maintain strength of muscles. This increases speed of contraction as in the case of marathon runner and also work well against load as in the case of weight lifter.
- *Delay in muscle fatigue:* Muscles need oxygen to contract. But when muscles are used for a long time during sport, available oxygen gets used up and lactic acid accumulates. This causes muscle fatigue. It is, therefore, important to do physical activities like stretching to delay muscle fatigue.



- *Maintaining correct posture and beautiful body:* Regular physical activities and yogic activity like asanas prevent postural deformities. Healthy muscles give the body a beautiful shape.

Oxygen Debt

During physical activities, respiratory rate increases. At the same time, oxygen gets speedily used up, this creates an oxygen debt, as the rate of oxygen intake may not match the oxygen requirement due to the exercise. Thus, maximum exercises are followed by a recovery period when oxygen debt is removed by obtaining more oxygen. For example, when an athlete is running and requires 3 litres of oxygen, if oxygen obtained is only 2 litres, oxygen debt of 1 litre is created, which gets recovered during recovery period.

- *Overall improvement in efficiency of muscle movements and reaction time:* Muscles contract on receiving stimulus from nerves. The time taken to react to the stimuli (reaction time) improves with regular physical exercise.
- *Increase in capacity for storage of food:* Regular physical activities help cells to store more food, which can be readily available for oxidation to provide energy when needed.

Respiratory system

- *Increase in size of lungs and volume of chest:* Physical activities require more oxygen. Therefore, more oxygen has to be inhaled. This provides exercise to the lungs and chest and as a result the size increases. Simultaneously, the diaphragm and rib muscles strengthen.
- *Increase in lung power:* Respiratory exercises, which include Pranayam and Anulom-vilom, improve lung power. The efficiency of alveoli or air sacs of lungs also improves.
- *Activation of unused (inactive) alveoli:* Active inhalation increases residual volume of air, tidal air and vital capacity which is important for healthy body.

Residual volume of air: Even after forced expiration some air remains in the lung, it cannot be expelled and is called residual air.

Vital capacity: Vital capacity is the amount of air inhaled and exhaled with maximum effort. In normal adult, it is 3500 cc to 4500 cc.

$$\text{Vital Capacity} = \text{TV} + \text{IRV} + \text{ERV}$$

(TV= Tidal Volume, IRV =Inspiratory Reserve Volume, ERV=Expiratory Reserve Volume)

TV: The volume of air breathed in and out during quiet breathing is called tidal volume.

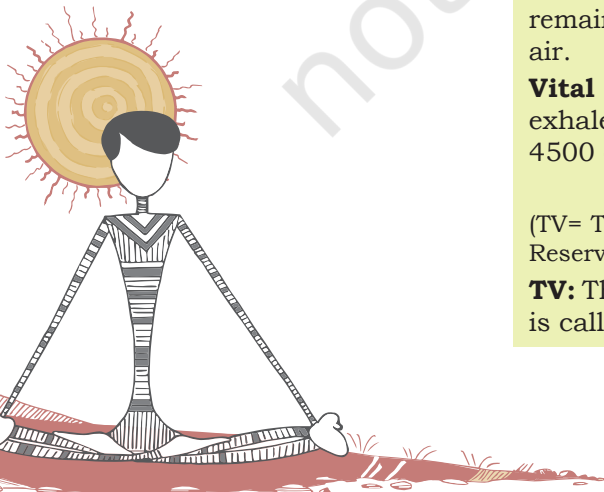

IRV: Air over and above tidal volume that can be breathed in upon continuous inhalation.

ERV: Air breathed out over and above TV upon continuous exhalation.

Exercising regularly makes vital capacity go upto 5500cc.

Circulatory system

Blood pumped into circulation transports oxygen and food to tissues, removes waste and also transports hormones to target organs. During physical activities, nutrients and Oxygen is needed by muscles to get energy for contraction. So heart pumps at a faster rate and circulation is speeded up. But this change is temporary. Certain permanent changes also occur when physical activities are undertaken regularly. These are given below.

- *Increase in the size of heart* occurs as cardiac muscles develop with regular physical activities. Regular exercise increases the capacity and thickness of the walls of the heart.
- *Increase in number of capillaries and blood cells:* The unused capillaries become active with physical activities making circulation efficient. An increase in the number of blood cells and amount of hemoglobin has also been observed.
- *Decrease in heart rate:* Under normal conditions the heart beats 72 times per minute at rest. But an athlete's heart rate may be found to be much lower at rest. The athlete's heart becomes so efficient that at rest same requirement is fulfilled with fewer heartbeats.
- *Increase in stroke volume:* Stroke volume is the quantity of blood pumped out by aorta in one stroke. Heart, having gained efficiency with regular physical activities, is able to pump out more blood in one stroke.

Activity 2.3

Complete the table given below to depict the positive effects of regular physical activities on organ systems.

Organ System	Positive effective of regular physical activities		
Muscular System		Improved muscle performance	
Respiratory System			Increase in stroke volume
Circulatory System	Pumping blood with more efficiency		

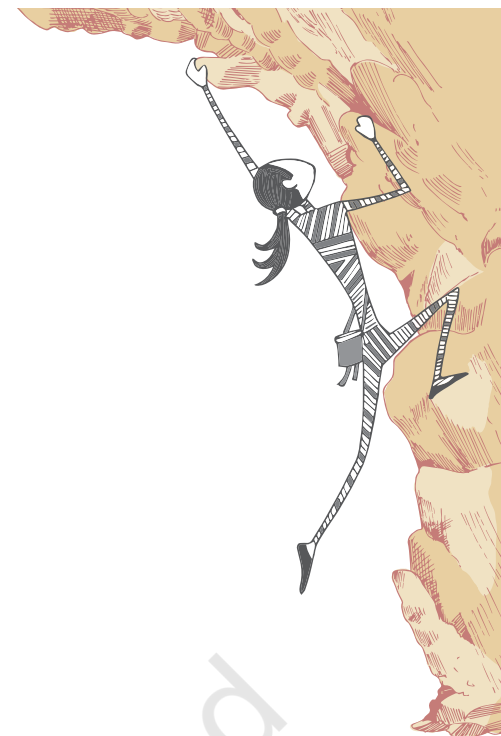

Activity 2.4

You have already studied asanas in your previous class. Write the names of asanas which can improve the —

- Respiration system
- Circulatory System
- Muscular system

- *Decrease in LDL and increase in HDL:* LDL and HDL are low density lipoproteins and high density lipoproteins respectively. Lipoproteins are secreted by liver. LDL, also known as bad cholesterol, adversely affects the blood vessels of the heart. On the other hand, HDL which is good cholesterol helps to remove cholesterol from the body. Regular physical activities help in production of more HDL and less LDL Thus physical activities help in reducing blood cholesterol.
- *Prevention of heart related illness/ailments:* It is well known that cardiac diseases and high blood pressure can be prevented by regular physical exercises.

EFFECT OF YOGA ON THE BODY

Yogic practice ensures good health and enhances physical fitness. Some of the asanas have been explained in Chapter 9. It has been found that these asanas develop muscles of the chest, abdomen and lungs and make them active. Some of you have already learnt this in Class IX.

Muscles of the rib cage are involved in respiration so the asanas indirectly improve respiration. Regular Yoga practice also improves blood circulation.

Apart from asanas, suryanamaskar is an integral part of yogic practice. Suryanamaskar improves blood circulation and makes the lungs strong.

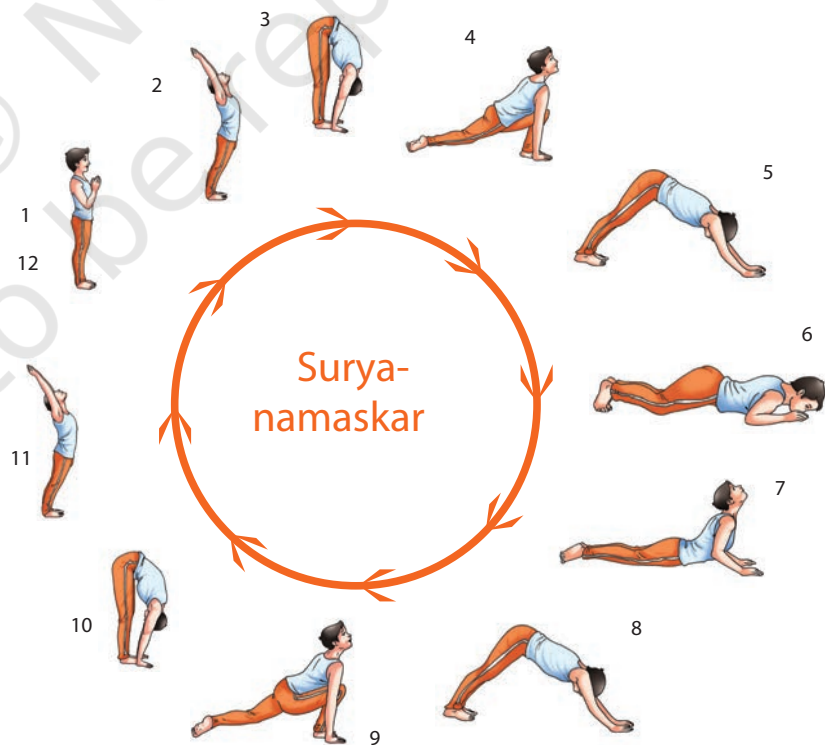

Fig. 2.10: Suryanamaskar



Activity 2.5

Words related to human body are hidden in the matrix given below. Search for them by going up or down, or even diagonally. Circle each of the discovered word.

X	M	Y	L	M	V	N	Q	O	T	W	Z
Y	N	T	U	I	R	P	C	X	M	C	D
P	I	X	A	C	T	I	N	Y	L	J	N
F	B	N	L	J	X	W	I	Z	R	O	Z
M	Y	O	S	I	N	F	T	X	I	N	R
R	Q	M	T	P	G	S	C	T	Y	Z	N
X	C	Y	U	N	I	U	A	V	O	Y	T
P	A	L	N	U	X	R	Y	Z	Q	C	M
W	R	U	R	Q	I	E	A	W	A	S	Q
S	D	T	H	P	N	L	I	T	X	Z	Y
A	P	Z	X	M	O	C	U	Z	I	N	M
U	A	E	G	R	D	S	H	E	R	O	S
W	C	P	F	Q	N	U	Y	X	M	Z	N
U	Z	S	T	N	E	M	A	G	I	L	Z
L	B	R	E	A	T	H	I	W	N	G	X



ASSESSMENT

I. Answer the following Questions

1. Give one example to show that organ systems work in unison. You may mention two or more organ systems to support your point.
2. Ravi is a good athlete. Give one permanent effect of being an athlete on his muscular system, and respiratory system.
3. "Physical activities are necessary for developing a healthy body and healthy mind." Give two examples in support of this statement.
4. Complete the sentence —
The respiratory system gets positively affected by undertaking yoga exercises regularly because _____.
5. Mention two changes that take place in each of the circulatory and respiratory systems due to regular physical activities.
6. Some of your friends avoid physical activity. Other friends are always eager to participate in physical activities. Prepare a health profile of your friends who indulge in games and yoga regularly. Indicate what physical activities they undertake regularly. What is the time duration? How do those who are physically active get motivation to play some games or exercise regularly? Present your findings in class and allow your peers in the classroom to add to the profiles you prepared.





GROWTH AND DEVELOPMENT DURING ADOLESCENCE



You have learnt in previous classes that growth is a natural phenomenon. 'Growth' is a characteristic of all living beings. The period of growth and development from childhood to adulthood is a period full of joy and challenges is known as 'adolescence'. This chapter deals with key aspects and issues related to the period of adolescence.



1077CH03

GROWING UP DURING ADOLESCENCE

Life cycle begins at birth. It is generally divided into seven functional stages of development of life as shown in Table 1.

Table 1: Biological changes in human life cycle—names, duration and characteristics

Biological stages of human life	Duration	Characteristics of growth and development
Prenatal	280 days of pregnancy	Development of foetus in mother's womb till delivery of fully formed fetus.
Neonatal	Birth to 28 days	Rapid growth and development such as smiling, recognising mother, etc.
Infancy	28 days to 1 year	Speedy growth in size and height, beginning of milk tooth, trying to stand and take steps.
Childhood	1 to 10 years	Rapid to moderate growth depending on nutrition. Permanent molar teeth eruption.

Adolescence	10 to 19 years	Rapid physical, mental, emotional and social changes.
Adulthood	20 years onwards	Maturation, reproductive period of life.
Old age	60 years and above	Slow weakening of body functions, organs and organ systems.

Note: Adolescence is a crucial period in the life cycle of human beings.

UNDERSTANDING ADOLESCENCE

The period of adolescence begins with the onset of puberty, during which certain hormones get activated. It is an increase in secretion of sex hormones (testosterone in males, estrogen and progesterone in females). Puberty merges into adolescence at around 10 years of age, and adolescence generally lasts till 19 years of age. You may recall the discussion on adolescence in the chapters of your Class VIII textbook of science and the Class IX textbook of Health and Physical Education.

During this phase, significant physical and psychological changes take place. However, as you have already learnt in your previous classes, the timing of these changes varies with every individual.

Unique features of adolescence

The two unique features of adolescence are —

- (i) The spurt in physical growth, when a physical appearance of an individual gradually becomes different. This is due to the rapid acceleration in growth of skeletal tissue (bones and cartilage) and muscular and glandular tissue. For examples, breasts begin to develop in girls due to the release of estrogen hormone. Changes in voice are quite noticeable among boys.
- (ii) It is a time period between the onset of puberty and adulthood.

Growth spurt in adolescents

As you would have experienced yourself, the changes during adolescence occur speedily and alter the body size and shape of adolescents. Suddenly the child seems to have grown up into a young adult. This is called growth spurt and is shown through the following flow chart.

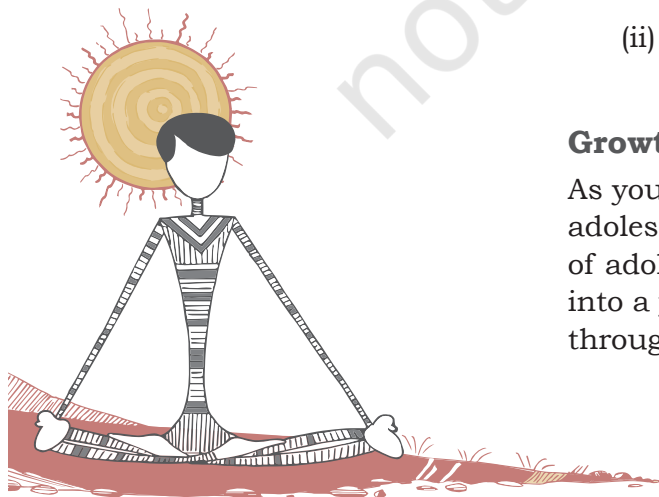

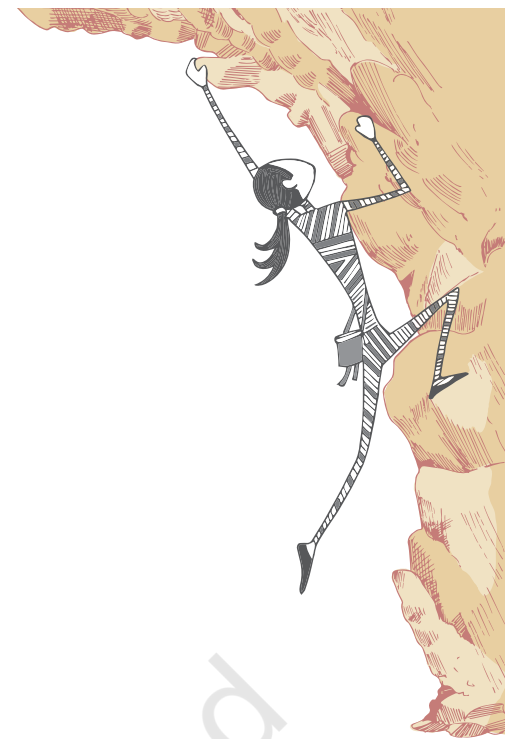
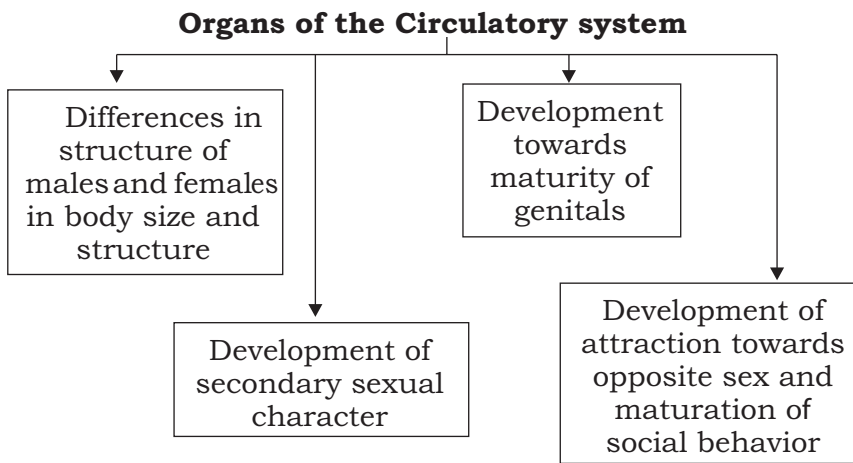

CHANGES IN BODY SIZE AND STRUCTURE

Under the influence of growth hormone, the body size increases. Sex hormones stimulate growth and maturity of gonads (reproductive organs). In males, testes grow in size and start producing sperms. In females, the eggs or ova present in the ovary since birth begins to mature. Sex organs also increase in size. Thus, there is an overall growth in body size. As sexual maturity progresses during adolescence, hormones act on growth centers of bones which are responsible for increase in length of bones. The long bones, the vertebrae and limbs grow and the adolescent gains height. The limbs become stronger. The heart, lungs and other internal organs also grow to match the increase in body size. The muscle mass undergoes a spurt at adolescence. Eventually, growth rate slows down and then stops. Generally, at the age of 14 to 18 years of age, adult height is already reached. The peak of growth of muscle mass is also typically around the age of 14 to 16 years. In the females, the pelvis region undergoes a growth spurt and becomes wider.

SECONDARY SEXUAL CHARACTERISTICS

In earlier classes, you have learnt about secondary sexual characteristics. As a result of physical changes, secondary sexual characteristics begin to develop in both girls and boys. Some characteristics are related to girls; some to boys and some are common for both. You may understand this development better by conducting Activity 3.1.

Activity 3.1

Identify the secondary sexual characteristics of adolescence during 10 to 19 years in the given table. Fill the following table by putting a tick mark (✓) at appropriate place in each column.

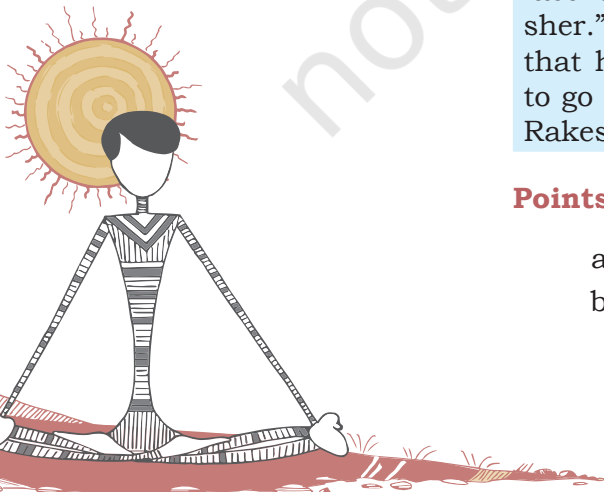

Changes	Girls (1)	Boys (2)	Both (3)	Don't know (4)
1. Increase in height and weight				
2. Menstruation				
3. Change in voice				
4. Growth of hair on private parts				
5. Widening of shoulders				
6. Broadening of hips				
7. Development of breasts				
8. Sweat and oil glands become active				

WET DREAMS

Wet dreams are a normal and natural physiological process which starts during adolescence among boys. It usually occurs during sleep. Wet dreams is a discharge of semen (seminal fluid) containing sperms. Many adolescent boys are usually not aware of this phenomenon and get worried when they face this situation first time.

Semen is the fluid formed by glands associated with male reproductive system. Semen carries mature sperms formed in the testes.

Read the following case studies which confirm the uniqueness of every individual with regard to time of occurrence of changes during adolescence.

CASE 1: My father calls me 'Sher'

Rakesh and Dibang, students of Class IX, are walking home together from school. Rakesh begins to tease Dibang, saying that he speaks in a girl's voice. He also laughs at the fact that Dibang has got no hair on his upper lip. "Look at me," Rakesh says, "I am a real man. My voice is strong and my face is manly - I have so much facial hair. My father calls me sher." Dibang wonders what is wrong with him. He recalls that his mother still calls him 'my sweet boy'. He decides to go home and ask his mother why he is so different from Rakesh and whether something is wrong with him.

Points for Discussion

- What do you think Dibang felt with Rakesh's remarks?
- Do you think that there is something wrong with Dibang? Why?

- c) What should Dibang's mother tell him?
- d) Do you think it is important to prepare children regarding the changes likely to occur in them? Why?

CASE 2: Each one is unique

Pooja, Sujatha, Abida and Radha are good friends. All of them are 13 years old and love to spend time with one another. They have so much to talk about, a new film, a new dress, home work, the boys in the class and just about everything.

Yesterday, Radha seemed uncomfortable. She was having her periods and was concerned about staining her uniform. Last month, Sujatha's family had organised a big celebration in her honour as she had started her periods. Pooja recalled that three months ago, Abida had started her periods in school and had to borrow a sanitary napkin from her older cousin. Except Pooja, all her friends have started their periods. Is there something wrong with her?

Points for Discussion

- a) What do you think Pooja felt when she realised that she is the only one who had not started her periods?
- b) Do you think there is something wrong with Pooja?
- c) If Pooja came to you for advice, what would you tell her as a peer?
- d) Do you think it is important to prepare children regarding the changes likely to occur in them? Why?

CASE 3: Puberty in boys

Suresh heard from someone that wet dream (nocturnal emission) causes weakness. When Naresh who is Suresh's best friend first experienced wet dream, he confided in Suresh. Suresh encouraged Naresh to visit the nearest Health Centre to have a discussion about wet dream with the doctor.

Points for Discussion

- a) Do you think something is wrong with Naresh?
 - b) According to you, the advice given by Suresh is correct or not?
 - c) What are the myths associated with wet dream?
 - d) What advice was given by the doctor to Naresh?
- Adolescence is a period of physical and emotional changes which are triggered by a set of hormones. These changes are part of growing up.
 - These changes occur at different times for different individuals.



- You should not compare your physical changes with others – the pace at which changes take place differ from person to person.
- It is natural to feel awkward or conscious of the changes that occur but try to support each other by accepting these as part of a natural process and don't let these decrease your self-confidence.
- If you have any doubts or concerns about changes that are occurring to you reach out to a trusted adult or you can talk to a counsellor in the adolescent friendly Health Clinic near where you live.
- Many young boys due to feeling of shame visit quacks and waste lot of time and money. It is best to visit the doctor or the health centre. One can discuss the myths related to growing up with a trusted person (teacher, parents, friends).
- There is a myth that wet dream causes weakness among the males because semen is lost from the body. However it is not so, semen and sperms are continuously made in the testes and semen lost during wet dream gets replaced very soon.

MENSTRUATION

The first menstruation is termed as menarche. In India, age of menarche is 12-13 years but may vary from individual to individual. Menstruation generally stops between the age of 45 and 55 years and is termed as menopause. Menopausal age varies in different individuals. Age of menarche has decreased due to various lifestyle changes. Menstruation hygiene and cleanliness is very important. Points to remember —

- Regular bath and washing self properly are important for avoiding infections, especially during menstruation.
- Change undergarment regularly (at least once a day) and avoid synthetic cloth.
- During menstruation, cloth, cloth pads or napkins should be changed after every four to six hours to avoid infection.
- One can also use sanitary napkins to manage menstrual hygiene. Many girls and women also make sanitary napkins at home with old cloth and cotton. If one makes a sanitary napkin at home, use only clean, soft cotton cloth. Do not use old cloth that may have any metal or plastic parts in it like glitter, gota or hooks and buttons. This may hurt or cause infection.
- If a cloth is used again as pad, it should be washed thoroughly with soap and dried in sun before next use as sunlight is an excellent disinfectant. Do not use dirty or damp cloth as it causes infections.



- Child With Special Need (CWSN) should be shown the process of maintaining hygiene or explained in detail if necessary.
- Sanitary pads should be wrapped in paper and disposed in trash bins or buried deep in a pit. Some schools have Incinerators which offer another safe way to dispose sanitary pads. There should be no shame attached in the process of disposing sanitary pads.

Government is supporting schemes for promoting menstrual hygiene among adolescent girls (10-19 years). Sanitary napkins are made available in schools or by ASHAs at a subsidised rate.

PSYCHOSOCIAL CHANGES DURING ADOLESCENCE

Psychosocial changes mean changes in thoughts, mood, attractions and friendships. The word ‘social’ is associated with the word ‘society’. As adolescence sets in, a boy or girl becomes psychologically aware of self and society. As a result, the adolescents build their own image and personality. This gives confidence to the adolescent to move in the society.

Adolescence is a transitional phase between childhood and adulthood. During this transitional period the adolescents get confused regarding their emerging role in the family and society at large. The physical changes in adolescents are accompanied by psychosocial changes. Adolescents get attracted towards opposite sex or become part of a peer group. Such changes tend to make them more dependent on the peer group in neighborhood, among classmates, etc. This often creates stressful relationships with parents, teachers and elders. Sometimes these developments may make them insecure about future. Adolescents who become aware of these changes, overcome this phase comfortably.

The social changes are reflected in the behavior of adolescents with peers and parents. They differ from parents on many issues and develop the confidence to express their own opinion emphatically if parents are friendly and understanding. Adolescents are more friendly with their peer group. However belonging to a vulnerable age group, adolescents may feel pressurised under the influence of peers. Everyone feels the need to have friends but during adolescence the need for friendship is more pronounced. The friendship may be with a peer or relative of one’s own age and someone of own sex or the other sex. It is, therefore, important for them to identify with whom they can share their ideas and identify ‘safety net’ in friends, parents and teachers.

Activity 3.2

Some psychological changes that occur in an adolescent are mentioned here. Write one or two sentences regarding them from your own experience. You may quote incidents involving others of your age.

- Developing a sense of identity.
- Distancing from parents.
- Closeness with peers.
- Curiosity for gaining knowledge.
- Experimentation



ADOLESCENT OR TEENAGE PREGNANCY

An adolescent is capable of reproduction. However, the reproductive maturity is reached only when a teenager is fully developed physically and physiologically. In India, because of early marriage, there are large number of adolescents or teenage pregnancies. If pregnancy occurs before reaching complete reproductive maturity, girls may risk their own health and that of the fetus (developing embryo).

Risks involved in adolescent pregnancy are mentioned below —

- An adolescent mother is not mentally prepared for motherhood.
- An adolescent mother is likely to be anemic.
- An adolescent mother is more prone towards maternal death while giving birth.
- Infant death are more among teenage mothers.
- There is likelihood of developing complications during giving birth.
- The baby born from teenage mother requires greater care which the teenage mother may not be able to give.
- The reproductive tract may be damaged during childbirth.
- Early pregnancy and motherhood delays development of education and career of adolescent mother.
- There may be economic problems and also problems due to psychological immaturity of the adolescent mother. This may hamper proper care of the infant.

Activity 3.3

Read the case study given below. Think and answer the questions that follow.

Rahul's grandmother and Sangeeta's grandmother were great friends. When Rahul grew up, his grandmother would often ask him to drop Sangeeta at her home. As a result Rahul and Sangeeta developed a liking for each other. When Sangeeta turned sixteen, the grandmothers insisted that Rahul and Sangeeta be married off as they were developing a relationship and that people would talk about it. Rahul was in college and Sangeeta had yet to finish school when they got married. After six months Sangeeta discovered that she was pregnant. Sangeeta was sad as she had dreams of pursuing higher studies and a career.

1. Were Rahul and Sangeeta right in agreeing to get married? Give reasons for your answer.
2. Do you think the adverse consequence of teenage marriage was greater on Sangeeta than on Rahul? Give reasons for your answer.
3. What would you have done, if you were in Rahul or Sangeeta's situation?

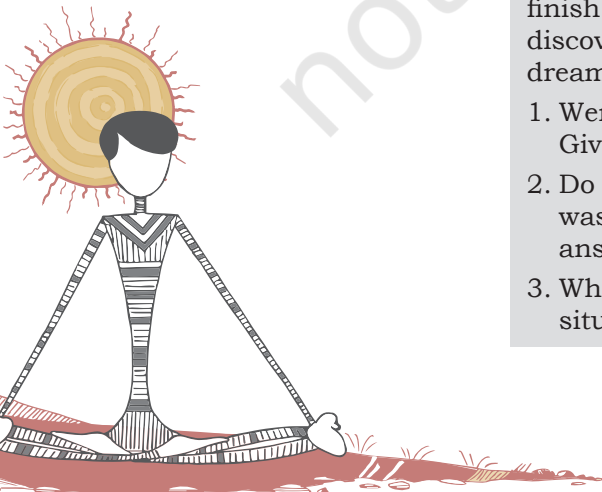

VITAL STATISTICS AND FUNCTIONS OF THE BODY

As you grow in years, you grow in size with increased length and circumference of body parts till you are a full-fledged adult of age 19. While you must maintain hygiene of all external parts, the internal organs also have to function normally. You know that certain vital functions of the body for enjoying good health are maintenance of blood pressure, pulse rate, respiratory rate, etc. Some ways of assessing the vital functions and statistics of human beings are given below.

Blood pressure (BP) and its measurement

Pressure exerted by blood on the wall of the arteries is called blood pressure. When the heart contracts, blood surges through aorta, BP is highest (Systolic Pressure) pressure of blood on the arterial wall recorded when ventricles relax is lowest (Diastolic Pressure).



Fig. 3.1: Checking blood pressure



Fig. 3.3: Sphygmomanometer

The pressure wave along the arteries with each heartbeat can be felt at the pulse. Blood pressure is measured by the instrument called “Sphygmomanometer”. Diastolic and Systolic pressure is measured and in a normal healthy young adult it is 110/75, which means 110 mm Hg systolic and 75 mm Hg diastolic. Sphygmomanometer consists of cuff with an inflatable bladder which is wrapped around a person’s upper arm and a rubber bulb inflates the bladder. An attached device indicates the blood pressure. There is now a digital device which is also used for measuring the BP. BP increases with age to about 130/90mm Hg. Abnormally high BP is called hypertension.

Activity 3.4

Measuring mid-arm Circumference

Biceps is the muscle of mid arm.

Place the beginning of the tapes in the middle of the biceps (midway between shoulder and elbow joint) take the reading and record it. When you do this in a group, record the circumference of all the students of the group and observe the variation.



Fig. 3.2: Measuring mid-arm circumference



Activity 3.5**Measuring height**

- Take your own height at intervals as you grow. You have learnt that your height at age 19 is almost the maximum height that you shall attain. Do this with your friends and try to figure out the reasons for variations. You need only an inch tape for this.
- Go to a clinic or any medical practitioner and see the working of the Sphygmomanometer. Collect data from persons where BP is checked. Analyse the variations and the reasons.

Activity 3.6

At the exit gate of Nehru Place Metro Station in New Delhi, there is a provision for measuring height and weight and also to calculate BMI for 10 rupees. Find out where else measurement of BMI is available. Do you have this in your school?

- My Height =
- My Weight =
- My BMI =

Normal, Overweight, obese.
Tick whichever is relevant

Calculate your Body Mass Index (BMI)

BMI can be calculated by adopting the following formula. Divide your weight by square of your height.

$$BMI = \frac{\text{weight (kg)}}{\text{height (m)}^2}$$

- If you measured your weight in kg then measure height in meters.
- Normal BMI Range = 18 to 25.
- Overweight = more than 25 and less than 29.
- Obese = more than 30.

Examination of conjunctiva

The conjunctiva is a transparent membrane over the eye. A smooth shiny moist conjunctiva is normal. If red or thick or covered by a secretion or foreign body, it requires immediate medical attention or consultation of an eye doctor.

Tongue examination

Nutritional deficiencies, infections, dysfunction of nerves or even cancer can be detected by examining the tongue.

Some key characteristic features of a tongue in normal condition can be noted by physical examination. These are —

- (i) Colour: Pink red on both upper and lower surface. On lower surface blood vessels may be seen.
- (ii) Texture: Rough on upper surface due to presence of papillae or taste buds. Hair, furores or ulceration indicates dysfunction.
- (iii) Size: If not swollen, tongue will fit comfortably inside the mouth. The tongue can be examined by the following steps —
 - Make tip of tongue touch roof of mouth to inspect ventral surface.
 - When protruded out, colour and texture can be noted for any deviation.
 - Use gauze to hold protruded tongue (wearing gloves) between tongue and index finger and fill the fender areas.

Examining nail bed

Nail bed also needs direct physical examination. Nail plate surface discolouration, abnormal cuticle, nail fold or nail shape require inspection. Loss of nails and lesions around nails, need medical attention.

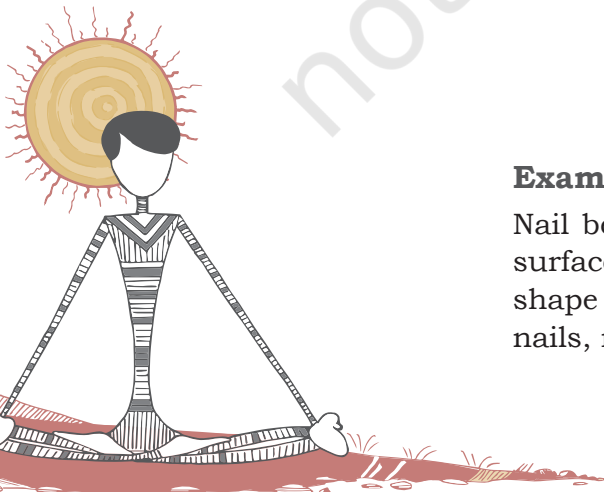

Pharmacology and its impact on the body

Pharmacology deals with biological effects of drugs. Drugs are chemical substances used for healing, curing diseases, slowing them or preventing diseases.

Effects

Therapeutic desired actions for cure are —

- Stimulating or inhibited cell function
- Blocking biochemical of tissues
- Anti histaminic (anti allergic)
- Laxative (reasoning constipation)

Unwanted effects

Side effects are —

- Dry mouth or dangerous effects on tissues
- Damage or toxicity or excessive bleeding are some effects of drugs used as medicine

Prevention

Never buy medicines over the counter (OTC) without Doctor's prescription with dosage and instruction written.

- Unusual responses are reasons for harmful effects of drugs
- Medication error or overdose



ASSESSMENT

I. Fill in the Blanks

1. Childhood is _____.
2. Adolescence is _____.
3. Five changes occurring in boys and girls during adolescence are _____, _____, _____, _____ and _____.

II. Choose the Correct Option

1. Proper hygiene should be practised during adolescence. (Yes/No/Don't know)
2. Wet dream is a normal phenomenon. (Yes/No/Don't know)
3. Government is supporting schemes for promoting menstrual hygiene among adolescent girls. (Yes/No/Don't know)
4. The adolescents begin to be extremely conscious of their physical appearance once secondary sexual characteristics begin to develop. (Yes/No/Don't know)
5. The adolescents begin to develop a strong sense of identity due to increased mental development. (Yes/No/Don't know)
6. Early pregnancy may end in damaged reproductive tract in girls. (Yes/No/Don't know)
7. Physical growth spurt during adolescence is embarrassing. (Yes/No/Don't know)
8. Change of voice in boys is a sign of adolescence. (Yes/No/Don't know)

III. Answer the following Questions

1. What are the health and educational implications of adolescent pregnancy?
2. Write down the process of the —
 - (i) mid-arm circumference.
 - (ii) measurement of height.
 - (iii) body mass index.
 - (iv) tongue examination.
 - (v) examination the nail beds.
3. Write a short note on pharmacology.

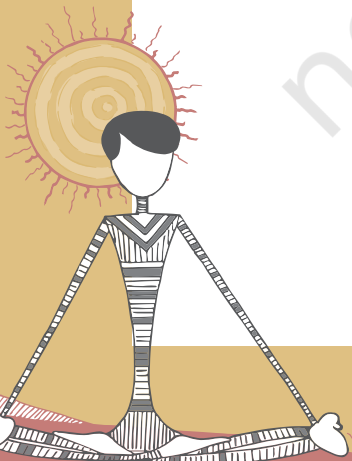



INDIVIDUAL GAMES AND SPORTS I



You might have participated in different games and sports. There are two broad categories of competitions which are played as individual games and team games. Team games are represented by more than two players. The example of team games are Football, Cricket, Hockey, Basketball, Volleyball, etc. Individual games are played with different events like, singles events, doubles or mixed events.

There are many individual sports, for example, Badminton, Table Tennis, Tennis, Swimming, Judo, Wrestling, etc. Track and field is also an individual sport which we will discuss in this chapter. We shall discuss various aspects of track and field, such as, history, rules and regulations, classification of track and field events.

TRACK AND FIELD

Track and field events are comprised with running events and field events. All running events are held in the track and categorised as short distance, middle distance and long distance running, race walk, hurdles and steeplechase events.

Field events are categorised as, throwing and jumping events. There are “combined events” which includes decathlon for men and heptathlon for women. Decathlon which is organised for men includes 10 events and Heptathlon for women includes 7 events. The events are described below with the help of Table 4.1.



1077CH04

Activity 4.1

- Enlist the events of Decathlon for men.
- List out the events of Heptathlon for women.

Table 4.1: Track and Field Events

Track (Running Events)	Field Events	
	Throwing	Jumping
(a) Short Distance Running Events 100 meter, 200 meter, 400 meter, 110 meter, Hurdles (men) 100 meter Hurdles for women 400 meter Hurdles (men and women)	<ul style="list-style-type: none"> • Javelin Throw • Discus Throw • Shot Put • Hammer Throw 	<ul style="list-style-type: none"> • High Jump • Long Jump • Triple Jump (Hop-step-jump) • Pole Vault
(b) Middle Distance Running Events 800 meter, 1500 meter (c) Long Distance Running Events 5000 meter, 10,000 meter 3000 meter Steeple Chase (m), 20 km walking, 50 km walking and Marathon (42.195 km).	Relay Events (a) 4 × 100 mtr (men & women) (b) 4 × 400 mtr (men & women) (c) 4 × 400 mtr (mix relay)	Combined Events (a) Decathlon (Men) (consist 10 events) 100 m, Shot put, High Jump, Long Jump, 400 m, 110 m. Hurdle, Discuss Throw, Pole Vault, Javelin Throw, and 1500 m. (b) Heptathlon (Women) (consist 10 events) 100 m. Hurdle, High Jump, Shot Put, 200 m. Long Jump, Javelin Throw, and 800 m.

Activity 4.2

- Find out why Marathon is 42.195 km?
- Collect information about different Marathon and their distance.

History

Track and field events are among the oldest of all sporting competitions. Running, jumping and throwing have been universal forms of human physical activities since the human beings exist. The first recorded example of organised track and field events is found in the Ancient Olympic Games held in 776 BC. The starting of the modern Olympic Games at Greece in 1896 was marked as new era for track and field events which was initiated by Pierre-de-Coubertin. Until the early 1920s, only males were participating in the track and field events. Introduction of five track and field events for women in the athletics was started during 1928 Summer Olympics. Gradually more women's events were introduced as time progressed. However, it was only towards the second half of the twentieth century that the men's and women's track and field events were given equal status. Furthermore, major track and field events for disabled athletes were first introduced at the 1960 Summer Para Olympics. From 1990's onwards, track and field events became increasingly more professional.

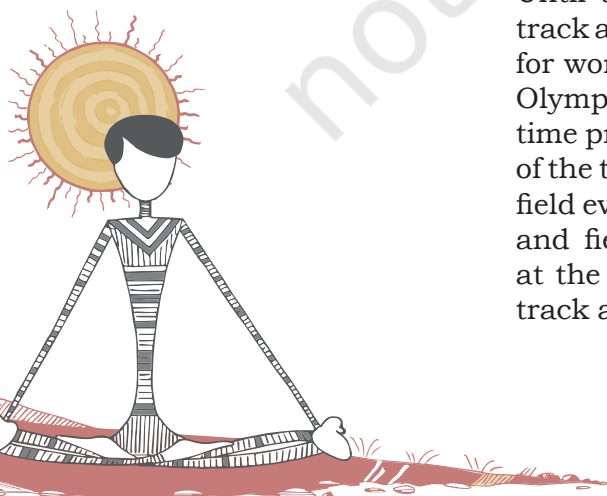

The World Athletics Federations (WAF) was formed and 200 nations became its member. Olympic Games are organised after every four years.

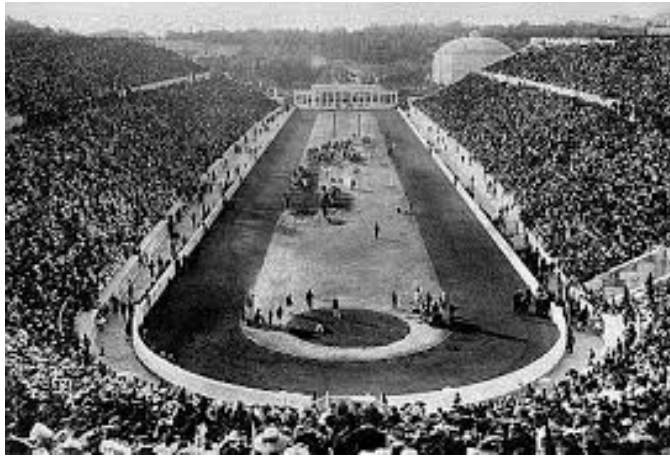

Fig. 4.1: 1896 Olympic Panathnaic Stadium track

TRACK EVENTS

Track events are running events on a track for specified distances.

These include (i) Sprints (100m, 200m, 400m), (ii) Middle Distance (800m, 1500m), (iii) Long Distance (3000m, 5000m, Steeplechase, 10,000m), (iv) Relays (4×100m, 4×400m), and (v) Hurdles (110/100m, 400m).

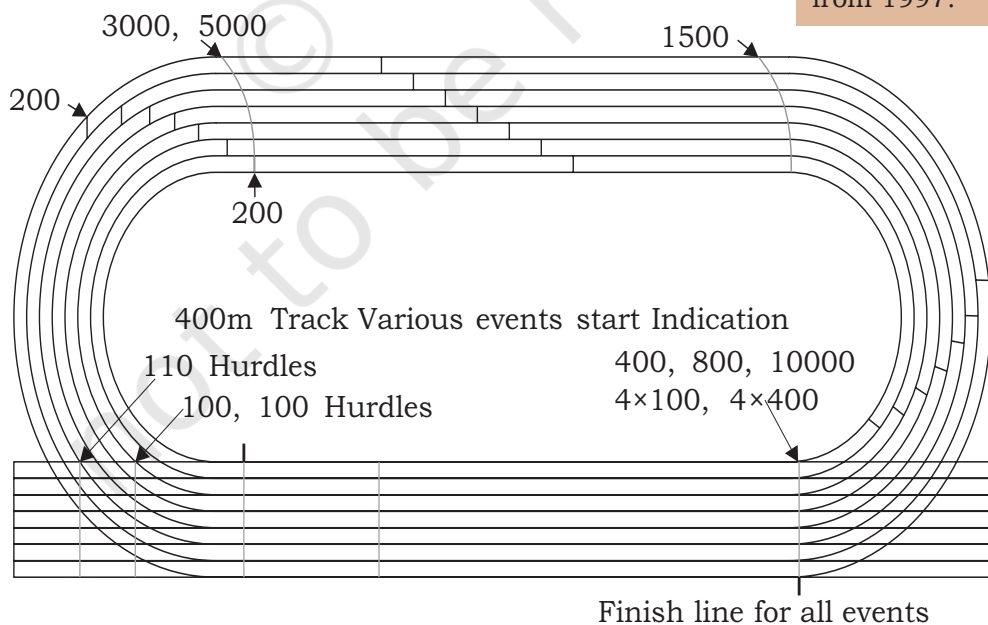

Fig. 4.2: Starting position of various events in 400 meter track

Activity 4.3

- Name the person who started Modern Olympic Games in 1896?
- Find out the colours of Olympic rings.
- What does it symbolise?
- Discuss for whom Para Olympic meant for and how many events?

Do You Know?

The IAAF World Championships in Athletics became a fully professional competition from 1997.

Sprints

Sprinting is the name given to short distance running in which the runner tries to maintain maximum speed for the whole race. These include track events covering distances of 100 meters, 200 meters, 400 meters, 4×100 meters relay, 4×400 meters relay, and hurdle races of 100 meters for women, 110 meters for men and 400 meters for both men and women. At the professional level, sprinters begin the race by assuming a crouching position on the starting blocks. Then they lean their body forward and gradually move into an upright position as the race progresses and momentum is gained. Athletes remain in the same lane on the running track throughout the sprinting distance. The man or woman who runs fastest and takes minimum time over 100m, wins the race.



Fig. 4.3: Sprint running

Activity 4.4

Tell the name of different starts in sprint events.

The winner is often named 'the fastest man/woman in the competition'. Some sprint events start in lanes, to cover the same distance for each runner.

Middle distance

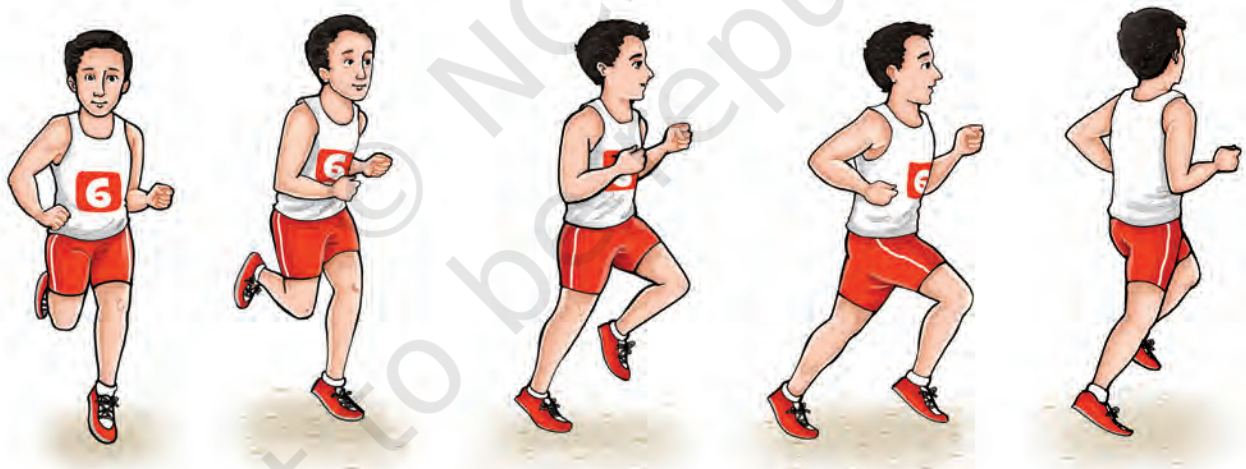
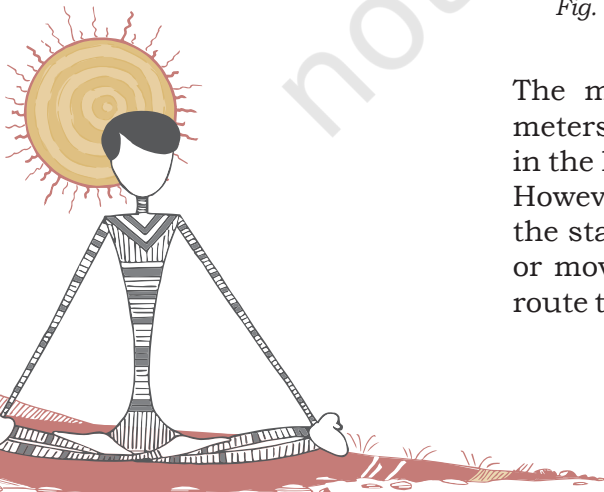

Fig. 4.4: Middle distance running

The middle distance races are of 800 meters and 1500 meters. Runners start the race from a standing start position in the lanes along a curved starting line or in staggered lanes. However the distance is same for each runner. After hearing the starter's pistol, they head forward in the designated lane or move towards the innermost track to follow the shortest route to the finish. Athletes rely more on speed endurance and



spacing than just pure speed. Middle-distance races require different skills and tactics to win the sprints competition. These races require that the athletes maintain a plateau pace, (i.e. the maintenance of speed at which the runner is running) that allows for a final spurt of speed, whereas sprint races need to be run at top speed for the entire length of the race.

Long distance

There are four common long distance running events in track and field. These are 3000 meters, 5000 meters and 10,000 meters and 3000 meters steeplechase. Long distance track races have much in common with middle distance races. However, in these races, pacing, endurance, and race tactics play an important role in performance. In these events, runners need to balance their energy to win the race.



Fig. 4.5: Long distance running

Relays

Relay races are the only track events in which a team of runners directly compete against other teams. Common relay races are the 4×100 meter and the 4×400 meter. The exchange of baton takes place within a specified area of the track called baton exchange zone. Teams may be disqualified if the team fails to complete the baton exchange within an area of 20 meters, the team is considered as disqualified. A team may also be disqualified if its runners have deliberately created hurdle for the other competitors. The 4×100 meter event is run strictly within the same lane on the track. It means that the team collectively runs one complete circuit of the track. Teams in a 4×400 meter event remain in



Fig. 4.6: Relay race

Activity 4.5

What are important points in relays? Practice relay baton exchange technique amongst your friends.

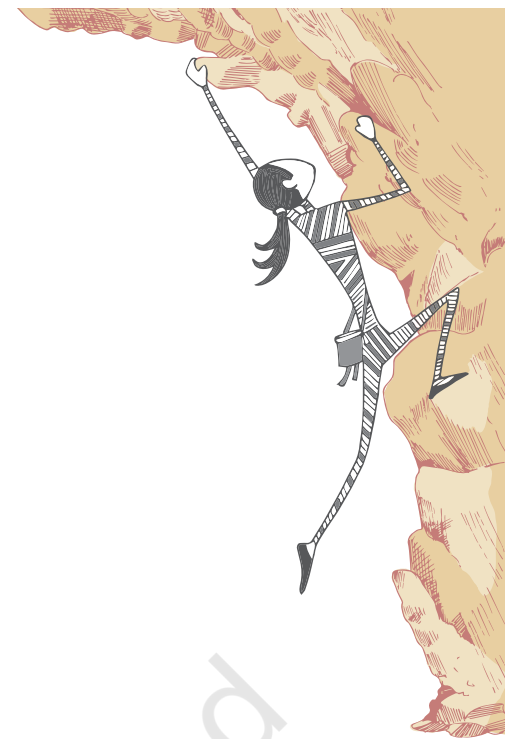

Activity 4.6

There are 28 hurdle jumps and 7 water jumps in 3000 meters steeplechase event.

their own lane until the runner of the second leg passes the first bend, at which point runners can leave their lanes and head towards the inner-most part of the circuit. For the second and third baton change-overs, team mates must align themselves in respect of their team position. The leading team takes the inner lanes while team mates of the slower teams must await the baton on outer lanes.

Hurdles

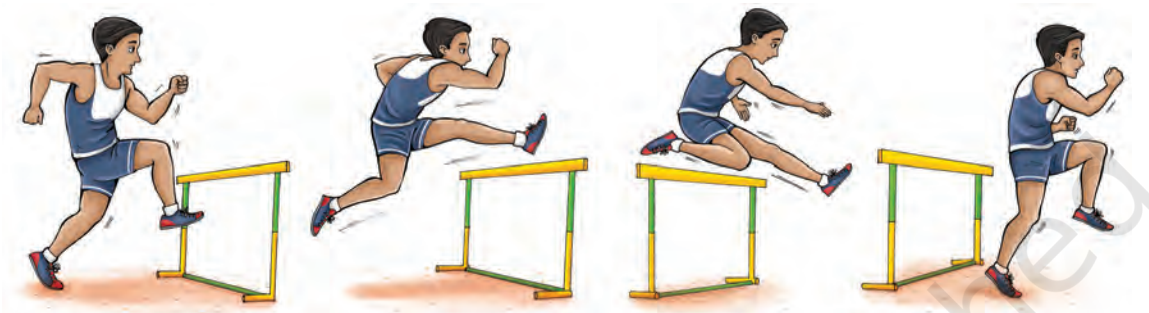

Fig. 4.7: Hurdles race

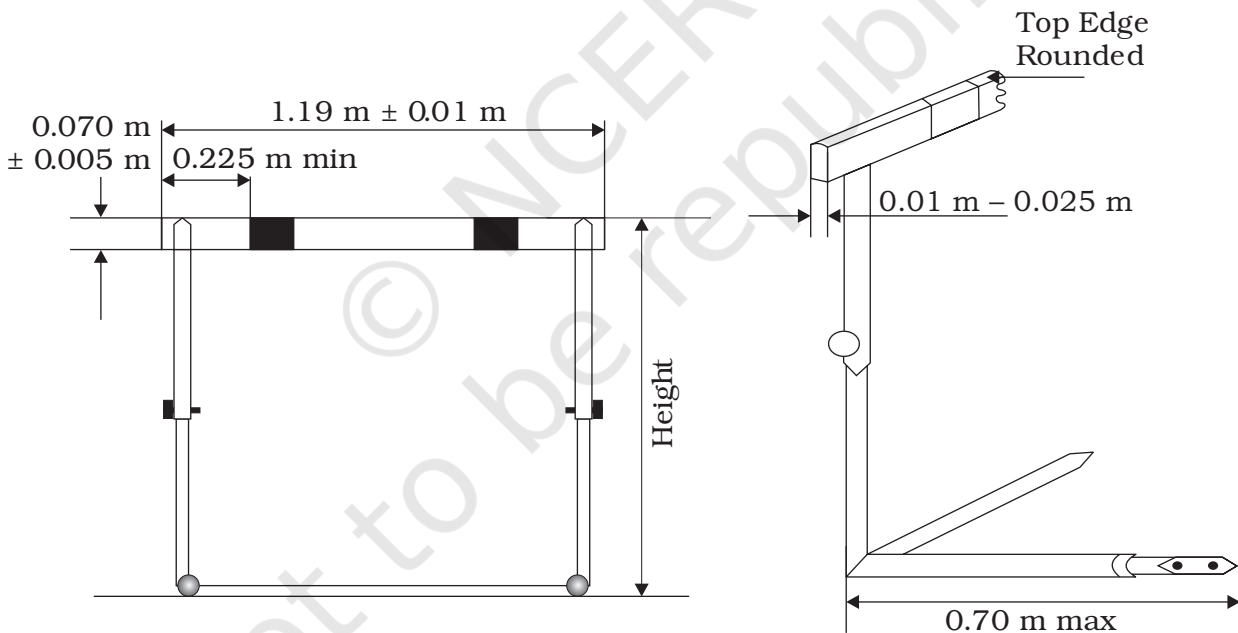
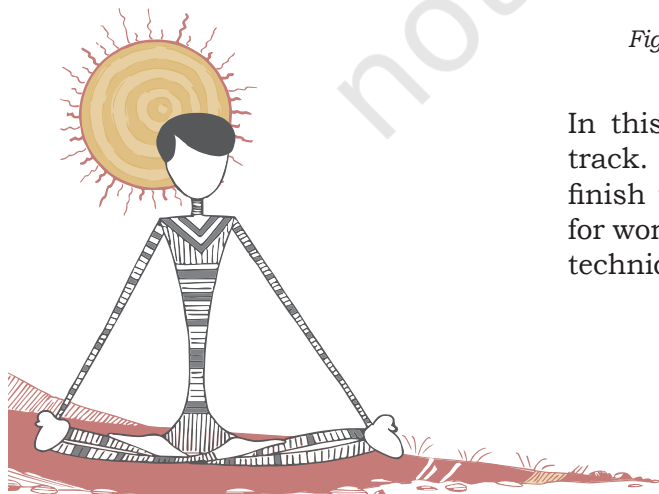

Fig. 4.8: Dimensions of hurdle

In this race, hurdles are placed at fixed intervals along the track. The runners have to run over them on their way to finish the line. Typical hurdle races are the 100m and 400m for women and 110m and 400m for men. Timing, footwork, and techniques are key in winning the hurdle events. Athlete needs



to run fast. The key factor to win in the hurdles race is to cross the hurdles without slowing down.

Dimensions: Standard heights of the hurdles

Distance	Men	Under 20 Men	Under 18 Boys	Under 20 Women	Under 18 Girls
110 m/100 m	1.067 m	0.991 m	0.914 m	0.838 m	0.762 m
400 m	0.914 m	0.914 m	0.838 m	0.762 m	0.762 m

Men under 20 and boys under 18

Distance of Race	Distance from start line to first hurdle	Distance between hurdles	Distance from last hurdle to finish line
110 m	13.72 m	9.14 m	14.02 m
400 m	45.00 m	35.00 m	40.00 m

Women under 20 and girls under 18

Distance of Race	Distance from start line to first hurdle	Distance between hurdles	Distance from last hurdle to finish line
100 m	13.00 m	8.50 m	10.50 m
400 m	45.00 m	35.00 m	40.00 m

Rules of track events

The rules of track events, as observed in most international athletics competitions, are formulated by the International Association of Athletics Federation (IAAF). Key rules of track events relate to three phases — starting, running and finishing.

Starting

- The start of a race is marked 5 cm wide by a white line. In all races, that are not run in lanes, the start line must be curved, so that all the athletes run the same distance upto the finish.
- Starting blocks shall be used for all races up to and including 400 meter (including the first lap of the 4x100 and 4x400) and shall not be used for any other race. No part of the starting block overlaps the start line or extend into another lane.

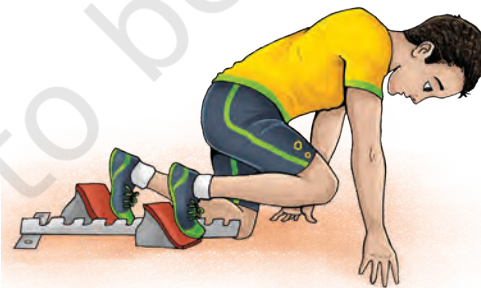

Fig. 4.9: Starting position for a sprint race

Activity 4.7

The details stated above aim at making us understand about the different types of running. Identify the different distances in each of the following —

- Sprints (1)
- (2)
- Middle Distance (1)
- (2)
- Long Distance (1)
- (2)
- Hurdles (1)
- (2)

- In most international competitions, the command of the starter is “on your marks” and “set” for crouch start and “on your mark” for standing start.
- Any sprinter with a false start is considered disqualified.
- Athletes are not permitted to run inside the inner curve of the track. They have to run in their designated lanes only.

Running

- In all races that are run in lanes, athletes have to keep themselves in their allocated lanes from start to finish. This also applies to any portion of a race run in lanes.
- If an athlete leaves the track or steps on the line demarking the track, this will be considered disqualified.
- An athlete, after voluntarily leaving the track shall not be allowed to continue in race.
- Any athlete found intentionally obstructing the path of another runner is also disqualified from the race.
- There are races that start in lanes and then at a “break line”, the competitors merge. Examples of this are the 800 meters and 4x400 relay race.

Finishing

- The finish of a race is marked by a white line 5 cm wide. Competitors are placed in the order in which any part of their torso (as distinguished from the head, neck, arms, legs, hands or feet) reaches the vertical plane of the nearer edge of the finish line.
- The measurement of time shall be taken from the flash or the smoke of the gun to the finishing touch, which shall be recorded in 1/100th of a second if taken manually. Fully automatic timing (FAT) is required for high level meets.

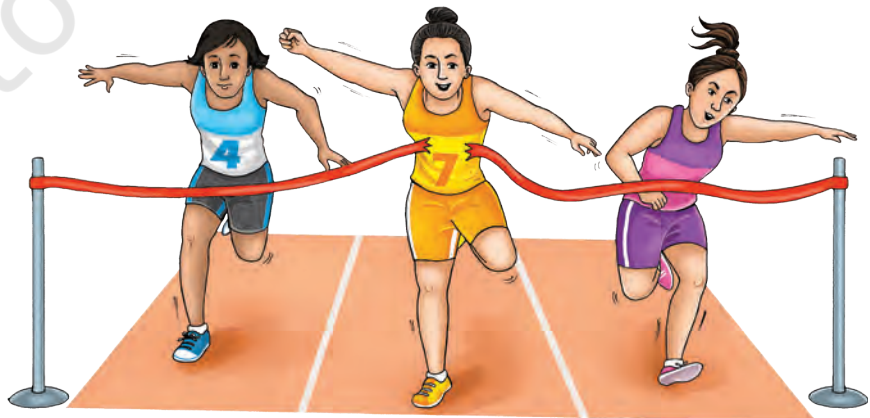
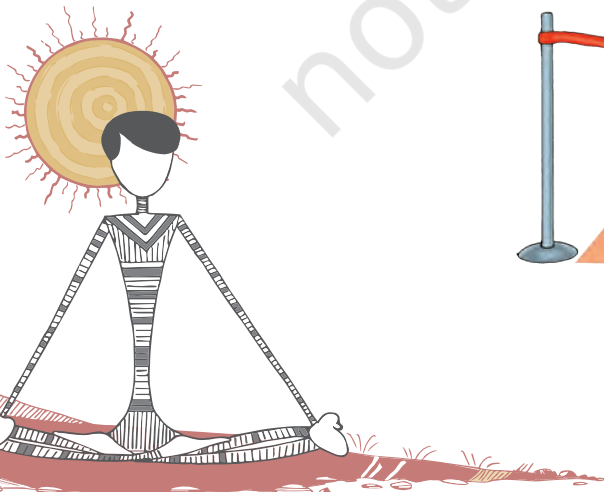

Fig. 4.10: Finishing position for a sprint race



FIELD EVENTS

Field events constitute of events that are participated by men and women outside the track. These include jumping events (Long Jump, Triple Jump, High Jump and Pole Vault) and throwing events (Shot Put, Discus Throw, Javelin Throw and Hammer Throw).

Jumping events

The jumping events comprise Long Jump, Triple Jump, High Jump and Pole Vault.

1. Long jump: The long jump is one of the oldest field events. The take-off has to be made from a 20 cm wide board one meter away from a pit. Athletes sprint along a length of track to a take off board and a sandpit. If any part of the runner's foot goes past the takeoff board, the jumper is considered for a foul and does not receive score for that round. Distance is measured from the end of the takeoff board to the nearest mark made by the jumper on the pit. Best eight competitors have a maximum of six rounds. Professional long jumpers typically have strong acceleration and sprinting abilities. However, athletes must also have a consistent stride to allow them to take off near the board while still maintaining their maximum speed.



Fig. 4.11: Long jump

2. Triple jump: Similar to the long jump, the triple jump takes place on a field heading towards a sandpit. This event is termed as the “hop-step and jump.” The event begins like a long jump, with competitor dashing down the runway and leaping from a takeoff board they first hop then take a step and then jump into the pit. The event is scored identically to the long jump.





Hop phase

Step phase

Jump phase

Fig. 4.12: Triple jump

Activity 4.8

Practice and measure separately hop step and jump

Activity 4.9

In case of tie in high jump practice how to break it.

3. High jump: In high jump event, competitors combined speed, to generate lift, with jumping technique. Jumpers may approach the bar from either-side, and land on a large, generally inflated cushion. In between, they must clear the 4-meter-long bar without knocking it off its supports. The bar will originally be set at a low height, at which competitors may choose to jump, or pass to another height. The bar is raised to a predetermined height after each round. Each competitor who either clears or passes a height advances to the next round. They are ranked according to the height they clear. An athlete is allowed a maximum of three trials of each height. Competitors are eliminated after missing (failing) three consecutive jumps in a particular height. Athletes have a short run up and then take off from near one foot to jump over a horizontal bar and fall back onto a cushioned landing area. Jumping technique has played a significant part in the history of the event. The modern technique of high jump as shown in the figure is known as “Fosbury Flop”.

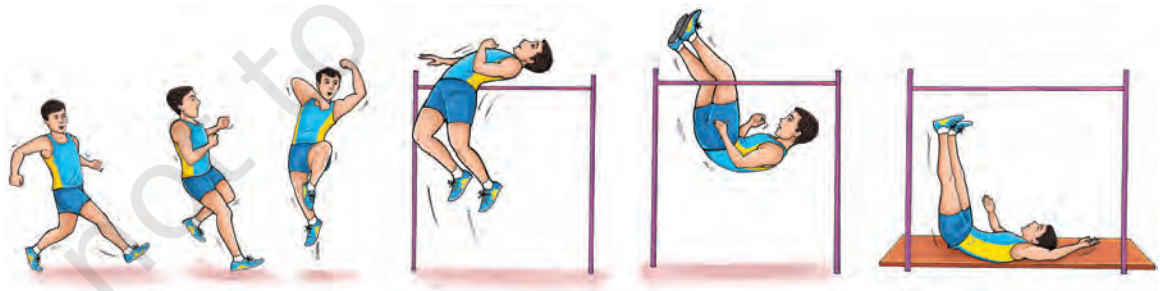

Fig. 4.13: High jump

4. Pole vault: Each vaulter sprints down the runway with a fiberglass or carbon fiber pole and plants the pole into the vaulting box. This box is specifically made of



fiberglass or carbon fiber. The athletes then push themselves over the crossbar and land onto the mattress.



Fig. 4.14: Pole vault

The rules require that athletes do not move their hands along the pole. As per technique, they begin clearing the bar with their feet first in a position so that the stomach faces the bar. As with high jumping, vaulters may touch the bar, as long as it doesn't fall. Round-by-round scoring rules are the same as for the high jump.

Throwing events

There are four major throwing events: Shot Put (putting the shot), Discus, Javelin and Hammer Throw. These are detailed below.



Fig. 4.15: Shot Put

1. Shot Put: In putting the shot event the athletes put a metal ball through the air for maximum distance. For male athletes, the metal ball weights 7.26 kg and for female athletes the weight is 4 kg. The athlete must stay in a circle of 2.135 m (7 ft) diameter until the shot has landed after throw. The put must be made from the shoulder with one arm only, and the shot must not be brought behind the shoulder. In shot put the athlete holds the shot close to their neck in one hand. Then they move in straight line or spin around for gaining

Activity 4.10

What is the weight of discuss for men and women?

Activity 4.11

- What are the lengths of Javelin for men and women?
- What are the weights of Javelin for men and women?

momentum and finally putting the shot in a pushing manner in the direction of the purified landing area.

2. **Discus:** In the discus event the athlete stands inside a throwing circle of 2.5 mt (8'-2½") diameter. As per technique he/she turns around one and a half times and throws the disc as far as he or she can. The disc is a round plate made of wood and metal and weighs 2 Kg for men and 1 Kg for women. When throwing the discus, the athlete must remain in circle. The feet of the athlete cannot leave this area before the discus lands. Even afterwards the athlete must leave the circle from rear half of the circle. Otherwise it is a fault and the throw will not be counted. The athlete will spin around to gain momentum, speed and then releases the disc in the proper direction. The athlete that throws it furthest from the front part of the circle (and within the legal area) wins the event.



Fig. 4.16: Discus throw



Fig. 4.17: Javelin throw

3. **Javelin:** The javelin is something like a spear. The official javelin size for women is 2.2 to 2.3 meters long and weights 600 grams. The weight of javelin for men is 800 grams and 2.6 to 2.7 meters long.



The javelin must be thrown in a specific way for it to be a legal throw. The athlete has to hold the javelin by its grip, throw the javelin overhand and cannot turn the back to the target when throwing. When throwing the javelin, the athlete runs down a runway to gain momentum and then must throw the javelin prior to crossing a line. The athlete cannot go over the line until the javelin lands. To avoid foul, the athlete must have a really good balance at the end of the throw. The athlete must leave the runway from behind the extended lines of the throwing arc.

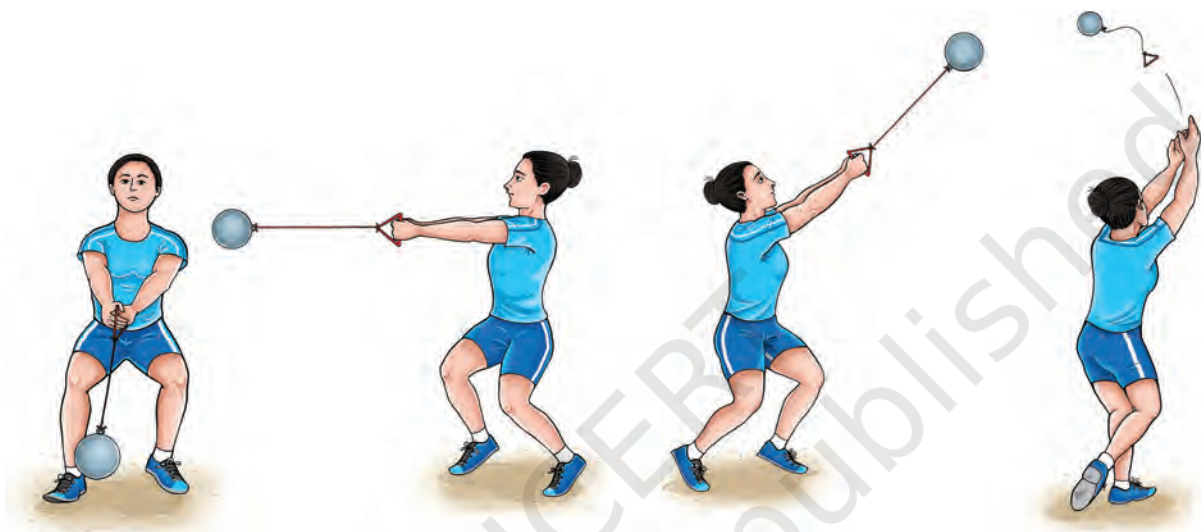

Fig. 4.18: Hammer throw

4. Hammer Throw: The hammer throw doesn't actually involve throwing a hammer like you would think. In this throwing event the athletes throw a heavy ball (7.265 Kg for men and 4 Kg for women) that is attached to a handle with a long (4 feet) wire. Like the discus and the shot put, the athlete must stay in a circle until the hammer lands. They spin several times to gain momentum prior to releasing the hammer. Balance is important due to the force generated by having the heavy ball at the end of the long wire.

Rules for field events

In general, most field events allow an athlete to take their attempt individually, under the same conditions as the other athletes. Each attempt is measured to determine who achieved the longest distance or maximum height.

- Horizontal jumps (long jump and triple jump) must be initiated from behind a line. In the case of throws, that line is an arc or inside a circle. Crossing the line while initiating the attempt will invalidate the attempt. It will be considered as a foul.

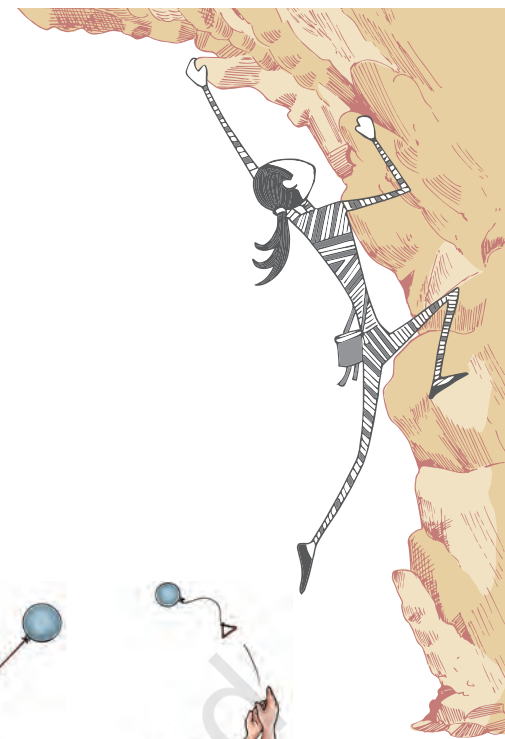

Activity 4.12

The details aim at making us understand that the athletes participate in different types of jumping and throwing events.

Identify —

Horizontal Jump (1)

(2)

Vertical Jump (1)

(2)

Throws (1)

(2)

(3)

- All landings must occur inside the area called safe. For the jumps, it is a sand filled pit, for throws it is a defined sector.
- A throw landing on the line, on the edge of sector, is a foul.
- Assuming a proper attempt, officials will then measure the distance from the closest landing point back to the line.
- Whenever a record (or potential record) occurs, that measurement is taken (again) using a steel tape and observed by at least three officials (plus usually the meet referee).
- The leading 8 competitors in jumps (Long Jump and Triple Jump only) and throws will get three more attempts in addition to the 3 attempts they already have taken.
- In vertical jumps (High Jump and Pole Vault), set the bar at a particular height.
- The competitor must clear the bar without knocking it off the stands that are holding the bar (flat).
- Three failures in a row will end the competitor's participation in the event.
- The competitor has the option to PASS their attempt.
- A pass could be used to save energy and avoid taking a jump. However, that would not improve their position in the standings.
- After all competitors have cleared, passed or failed their attempts at a height, the bar height will be raised.
- The height of the bar raised is predetermined before the competition. Though when one competitor remains, that competitor may choose their own selected height for the remaining attempts. A record is kept of each attempt by each competitor.
- After all competitors have taken their attempts, the one who jumps the highest height is the winner. The bar does not shift to a lower height except to break a tie for first place or a qualifying position. If those critical positions are still tied after applying the tiebreakers, all tied competitors will take a fourth jump at the last height.
- If they still miss, the bar will go down one increment where they will again jump. This process will continue until the tie is broken.



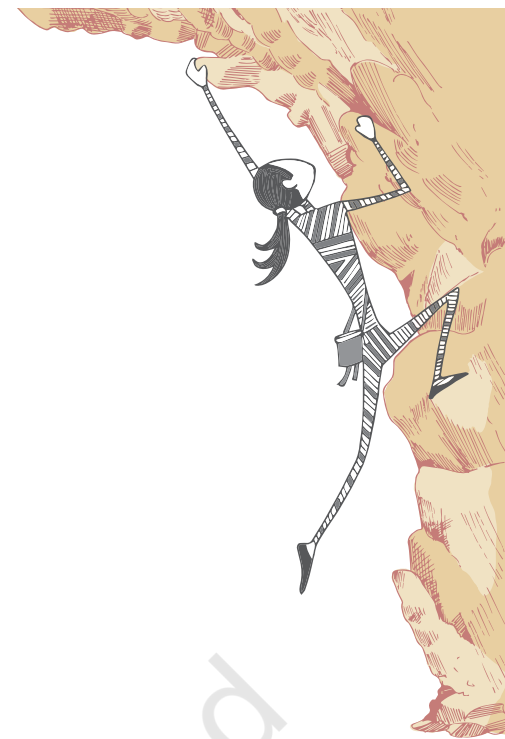

Activity 4.13

Given below the names of various events in one column. You have to identify the category of events each of these belongs to. Tick off in the appropriate column before the sports event. The category of one is marked as an example.

Changes	Categories of Sports Events		
	Running	Jumping	Throwing
Pole Vault			
Middle and Long Distance Run			
Long and High Jump			
Shot Put			
Hurdle Race			
Javelin			
Sprints			
Triple Jump			
Discus			
Relays			
Hammer			

Some Athletic World Records: Men (As on 01.06.2019)

Sr No.	Events	Time/ distance	Men	Country	Date
1.	100 m	9.58 sec	Usain Bolt	Jamaica	16 Aug. 2009
2.	200 m	19.19 sec	Usain Bolt	Jamaica	20 Aug. 2009
3.	400 m	43.03 sec	Wayde Van Niekerk	RSA	14 Aug. 2016
4.	800 m	1:40.91	David Rudisha	Ken	9 Aug. 2012
5.	1500 m	3:26:00	Hicham El Guerrouj	Morocco	14 July 1998
6.	Long Jump	8.95 m	Mike Powel	USA	30 Aug. 1991
7.	Triple Jump	18.29 m	Jonathan Edwards	Great Britain	7 Aug. 1995
8.	Shot Put	23.12 m	Randa Bornes	U.S.A.	20 May 1990

Some Athletic World Records: Women (As on 01.06.2019)

Sr No.	Events	Time/ distance	Women	Country	Date
1.	100 m	10.49 sec	Florance Griffith Joyne	U.S.A.	16 Jul. 1988
2.	200 m	21.34 sec	Florance Griffith Joyne	U.S.A.	20 Sep. 1988
3.	400 m	47.60 sec	Manta Koch	Germany	06 Oct. 1985
4.	800 m	1:53.28	Jarmila Kratochvilova	Czechosl ovakia	26 Jul. 1983
5.	1500 m	3:50:07	Genzebe Dibaba	Ethiopic	17 Jul. 2015
6.	Long Jump	7.52 m	Galina Chistyakoya	Soviet Union	11 Jun. 1988
7.	Triple Jump	15.50 m	Inessa Kravets	Ukraine	10 Aug. 1995
8.	Shot Put	22.63 m	Natalya Lisouskaya	Soviet Union	17 Jun. 1987

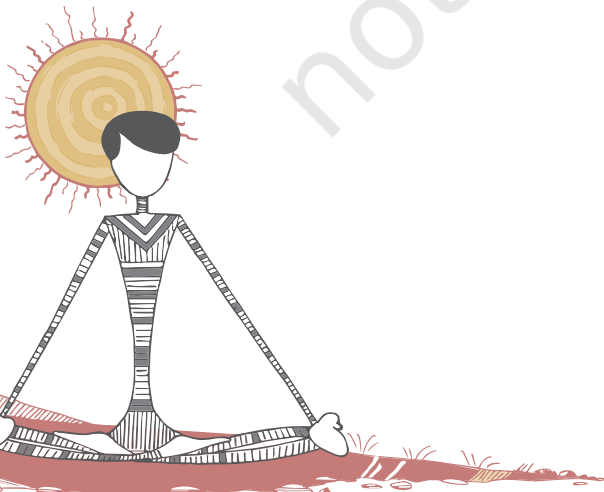

ASSESSMENT

I. Answer the following Questions

1. What are track and field events? Which of these also belong to the category of team sports?
2. What are the main track rules?
3. Describe the major rules that are observed in long jump.
4. Describe the special features of triple jump and high jump.
5. Discuss the specific rules for shot put and discus throw.
6. How do you break a tie in high jump?
7. How is high jump executed?
8. Describe various relay races.
9. In which events does the athlete take standing position to start the race?
10. How do these track and field events help an individual performance?

II. Fill in the Blanks

1. The standard track is of _____ meter.
2. The hurdles event common for men and women is _____.
3. The Diameter of discus circle is _____.
4. The baton exchange area in relay event is _____ meter.

III. State whether True or False

1. Modern Olympic Games started at Greece in 1896.
2. The weight of discus for men is 1 kg.
3. The official women javelin size is 2.2 to 2.3 meters long and weighs 600 grams.





INDIVIDUAL GAMES AND SPORTS II



1077CH05

Track and field events, as one of the major individual sports, have already been studied in the previous chapter. However there are other individual sports like Badminton, Gymnastics, Table Tennis, Tennis, Swimming and Combative Sports such as Judo and Boxing. We shall discuss these games in this chapter.

BADMINTON

Badminton is a racket sport played by either two opposing players (singles) or two opposing pairs (doubles). The players take positions on opposite halves of a rectangular court that is divided by a net. It is one of the few sports where men and women can play together. It is a game for all ages and abilities. Although fitness is a key aspect for professional players, it is also played as a recreation game across the world.

History

The origin of the badminton dates back to second century BC. Although it appears that this sport was named after Badminton House, Gloucestershire, owned by the Duke of Beaufort. In 1873, some British army officers in India initially played the game at 'Poonah' (now known as Pune) thus derived its name. In 1877 first set of rules were derived. These laws were gradually adopted by other nations. However, the game evolved as an international sport only after the first All England Championship. In 1934, the International Badminton Federation (now known as Badminton World Federation) was formed and the rules of the game were standardized. Badminton Association of India came into existence in the year 1934. Various state level associations are affiliated to it.

Events

The events played in badminton are: (a) Singles' (Men, Women), (b) Doubles' (Men, Women), (c) Mixed Doubles' (Combination of one Man and one Woman) and (d) Teams' Event (Men, Women, Mixed)

Court

The court is rectangular, and is divided into 2 halves by a net. Court is usually marked for both singles' and doubles' play. The doubles' court is wider than the 'singles' court.

The full width of the court is 6.1 metres, and in singles' this width is reduced to 5.18 metres. The full length of the court is 13.4 metres. The service courts are marked by a centre line dividing the width of the court, by a short service line at a distance of 1.98 metres from the net, and by the outer side and back boundaries. In doubles', the service court is also marked by a long service line, which is 0.76 metres from the back boundary.

The net is 1.55 metres high at the edges and 1.524 metres high in the centre. The net posts are placed over the doubles sidelines, even when singles is played.

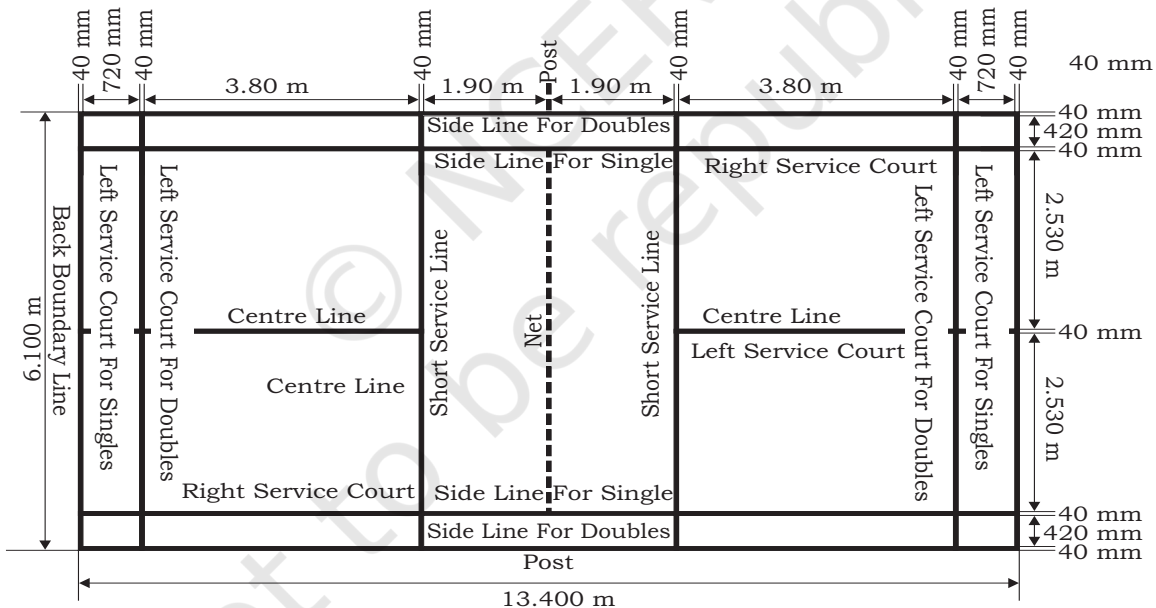
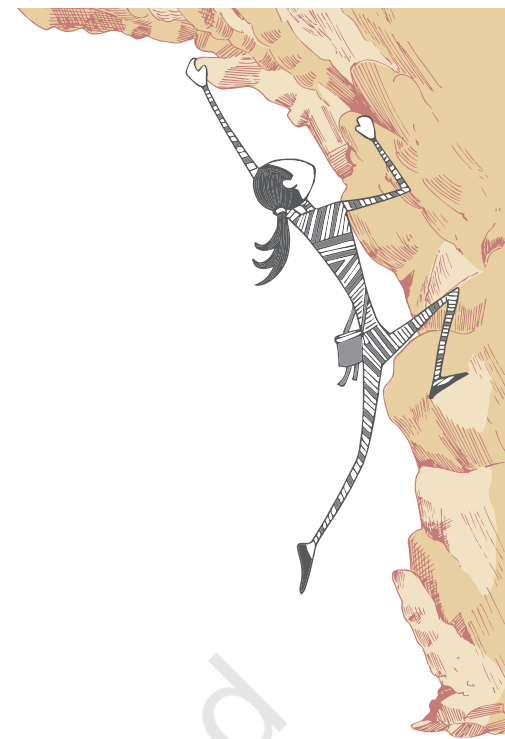

Fig. 5.1: Badminton court

Rules

Starting the game

A coin is tossed to start the game. The player winning the toss has the choice to serve first, or to choose which side of the court would they prefer. The player losing the toss gets the left over option.



Service

- At the beginning of the game of badminton and when the score is even, the server serves from the right service court.
- Server and receiver always stand diagonally in opposite service courts.
- The server's racket shall initially hit the base of the shuttle.
- While serving the whole of the shuttle shall be below 1.15m from the surface of the court at the instant of impact of the racket with the shuttle.
- Some parts of both feet of the server and receiver must remain in contact with the surface of the court until service is delivered.
- The movement of the server's racket must continue forward after the start of service until service is delivered.

Let

'Let' is called by the umpire, or by a player (if there is no umpire), to halt play. A 'let' may be given for any unforeseen or accidental occurrence. It shall be a 'let', if —

- there is an unforeseen or accidental situation occurs.
- during play, the shuttle is caught in the net or caught on the net and remains suspended on its top after passing over the net.
- the shuttle disintegrates and the base separates from the rest of the shuttle.
- the server and receiver are both faulted at the same time.
- the server serves before the receiver is ready.
- the line judge is unsighted and the umpire is unable to make a decision.
- in the opinion of the umpire, the play is disrupted or a player of the opposing side is distracted by a coach.

Faults

A player or player's side loses the rally, if the service or shuttle —

- is not correct.
- misses the shuttle during service.
- lands outside the court.
- passes through the net.
- fails to cross over the net.
- touches the walls or ceiling or ground before being retrieved.
- is hit twice.

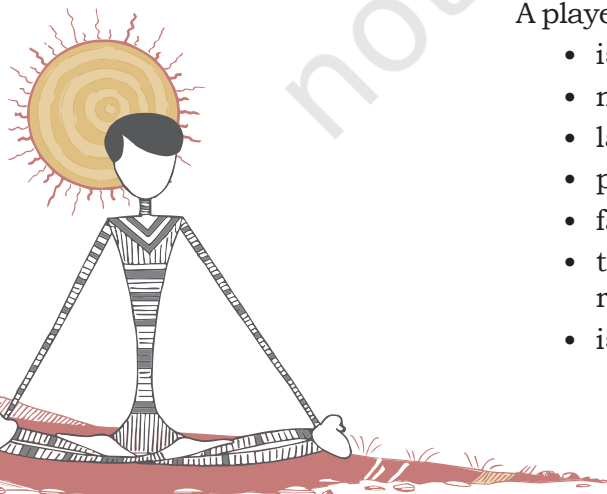

- hits a player, attire, equipment or any person or object outside the court.
- is hit by both the doubles partners in succession.
- is in play, the player's racket, parts of his body or his clothes touch the net or its support.

Fundamental techniques

1. Grip: Holding grip of a badminton racket is the foundation of playing this game. Holding the racket wrongly will reduce the power and accuracy of the stroke. The shots will be limited. A player needs to learn how to change grip quickly during games. Below are the two basic types of badminton grips.

Forehand grip

- This grip is used to hit shots on the forehand side of the body and around the head shots.
- In this a player holds the racket head in the non-playing hand, keeping the handle points towards the body. The face of the racket perpendicular to the floor.
- The player places the playing hand on the handle just like shaking hands with it, it is like a V shape in between thumb and index finger.
- For flexibility, the racket handle rest loosely in the fingers.
- In order to increase control and accuracy while serving and hitting from the forecourt and mid court, the grip is shortened and placed nearer to the shaft.

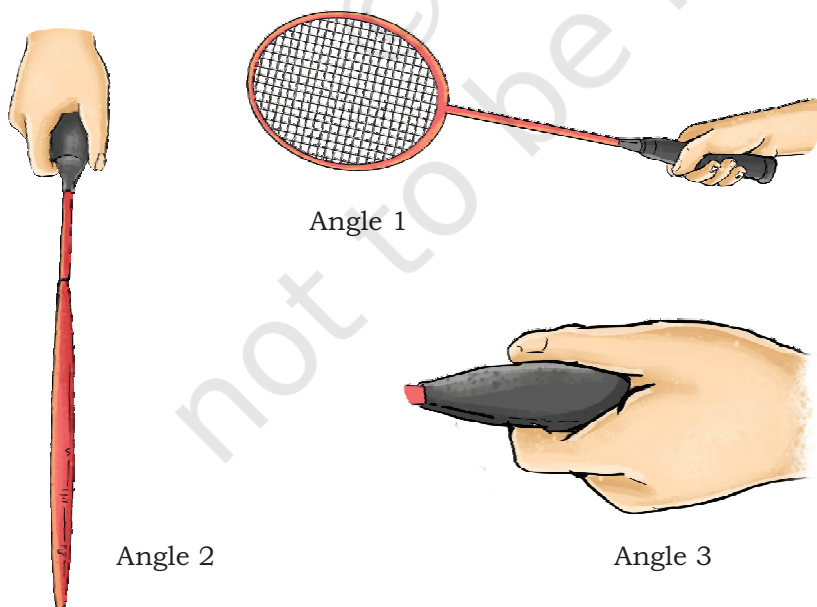
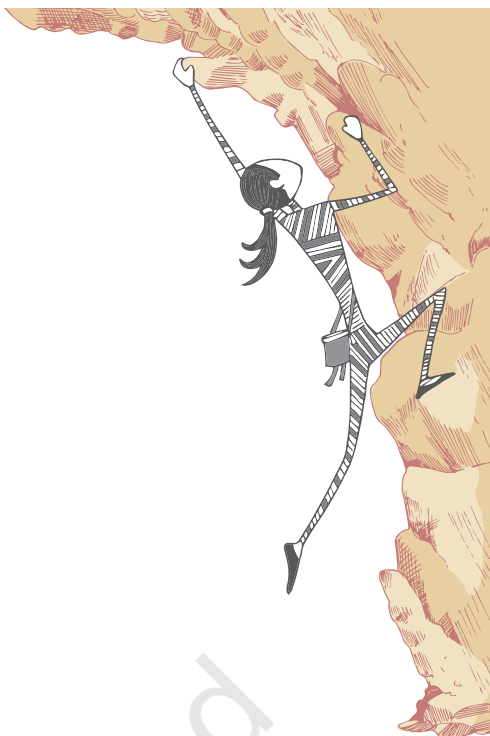

Fig. 5.2: Forehand grip



Backhand grip

- While playing backhand grip, shots is hit from backhand (left) side of player's body.
- The player holds the racket in the same way as it was held in forehand grip.
- The player turns the racket anti-clockwise so that the V shape moves leftwards.
- The player places the thumb against the back of the handle for greater leverage and power.
- The other techniques are the same as in forehand grip.

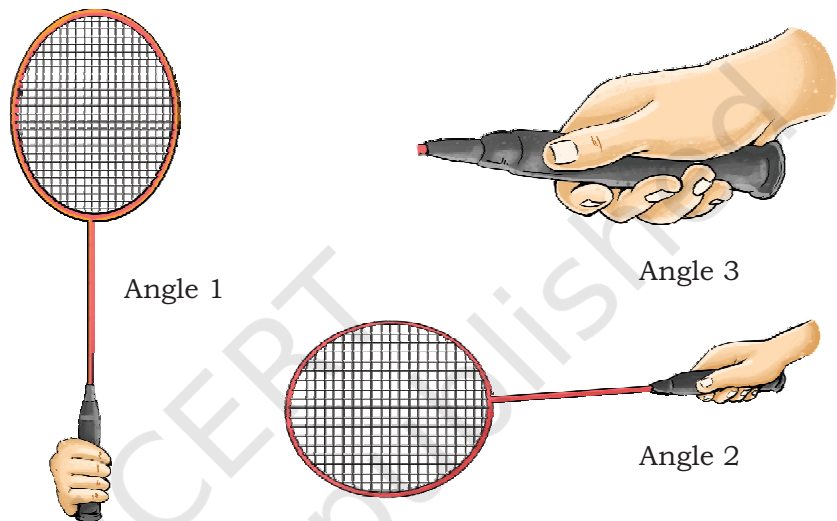

Fig. 5.3: Backhand grip

2. Service: There are basically three types of serves — high, low and flat. High service is the most basic of all strokes. One needs to learn this first when one starts playing the game. You need to concentrate on the following three broad points while delivering the high service.

- Stance: To deliver the high service, the player has to take a position about two feet from the short service line and about six inches from the centre line.

The player has to make sure not to touch the centre line as it will be called a touch fault. The player has to stand comfortably with both feet spread apart and parallel to each other and take the initial serving position. At this stage, the full weight of the body is on the back foot.

- Point of Contact: As one starts the forward movement of the racket, slowly start shifting the weight from the back foot to the front foot. The player then drops the shuttle and hit it high and

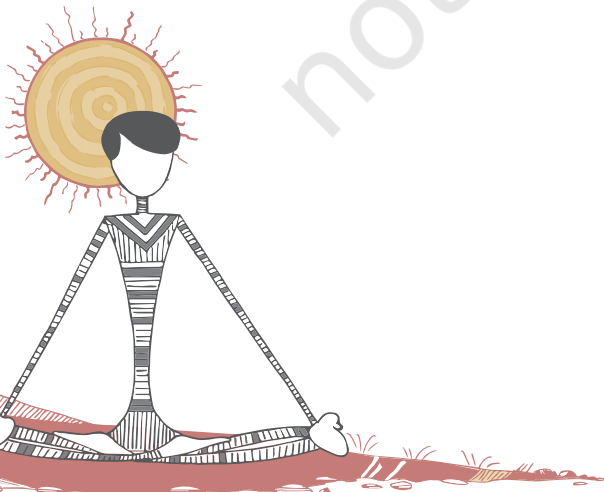

- back to the baseline. The player must make sure that the point of contact is always below the waist.
- Follow-through: Once the service is delivered, the player continues to swing the racket right across the left shoulder (or right shoulder if the player is left-handed). This is called the follow through.
3. Return of Service: This stroke plays a crucial part in a rally because good return of serve allows a player to dictate terms and control a rally till the point is won. However weak return of serve will allow the opponent to go on the offensive. While receiving the serve to hit the shuttle, normally players stand in the centre of the court with the left foot forward and place the weight of the body more on the front foot. It will help the player to receive all types of serves i.e. high, low and flick. In fact, players are advised to take the stance closer to the short service because in high serve the shuttle remains in the air for a longer duration. On a high serve, a player has the choice of playing an attacking clear, drop shot, smash or a half smash. Similarly, on a low serve, a player can flick, push or lift the shuttle to the baseline. It is important to try to meet the shuttle as close to the net as possible so that the receiver has more options available to choose the shots.

GYMNASTICS

Gymnastics is a sport that involves physical movements in a sequence. It requires physical strength, balance, coordination, endurance, flexibility and body control. It often involves dance moves, flips, twists, jumps and other moves. It helps children to develop physical coordination and motor skills, proper use of balance develop a good sense of precision and timing. It can be performed as a way to stay fit or specifically to compete in events locally, nationally as well as internationally.

History

Gymnastics was developed for fitness and beauty practices by the ancient Greeks. It included skills for mounting and dismounting a horse, and circus performance skills. The Greeks used gymnastics as military training. However, in the late eighteenth and early nineteenth century, the German physical educators created exercises for boys and young men on apparatus. Their design is considered as modern gymnastics. The Federation of International Gymnastics was founded in 1881. By the end of the

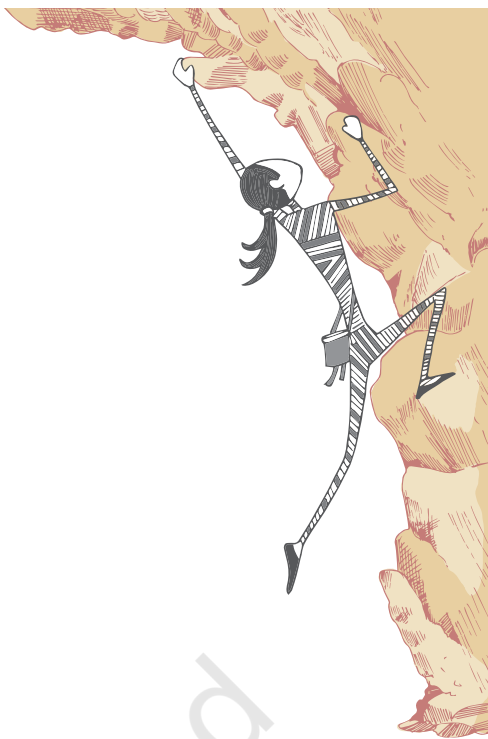

nineteenth century, men's gymnastics competition was popular enough to be included in the first "Modern" Olympic Games in 1896 and women gymnasts were included in Olympic Games in 1986. The first world cup in gymnastics was organised in 1975.

Forms of gymnastics

The major forms of gymnastics are: Artistic gymnastics, Rhythmic gymnastics, Trampolining, Tumbling and Acrobatic Gymnastics.

Artistic gymnastics

Artistic gymnastics is usually divided into Men's and Women's Gymnastics. Men compete in six events. These are floor exercise, pommel horse, still rings/roman rings, vaulting table, parallel bars, and horizontal bar. Women compete on four events. These are floor exercise, vaulting table, uneven bars, and balancing beam.

1. Events for men

(i) Floor Exercise: For this event a 12×12 square spring floor is required. A series of tumbling passes are performed to demonstrate flexibility, strength, and balance. The gymnast must also show strength skills, including circles, scales, and press handstands. Men's floor routines usually have four passes that will total between 50–70 seconds and are performed without music. As per rules, male gymnasts touch each corner of the floor at least once during their routine.



Fig. 5.4: Pommel horse

(ii) Pommel Horse: A typical pommel horse exercise involves both single leg and double leg skills. Single leg skills are generally found in the form of scissors, often done on the pommels. Double leg skill, however, is the main staple of this event. The gymnast swings both legs in a circular motion (clockwise or counterclockwise depending on preference) and performs such skills on all parts of the apparatus. Gymnasts will often include variations on a typical circling skill by turning or by straddling their legs. This makes the exercises of gymnast more challenging. A gymnast performs a dismount, either by swinging his body over the horse or landing after a handstand.

(iii) Still Rings: The rings are attached to a wire cable from a point to 5.75 meters from the floor, and adjusted in height so, that the gymnast has room to hang freely and swing. The gymnast performs a

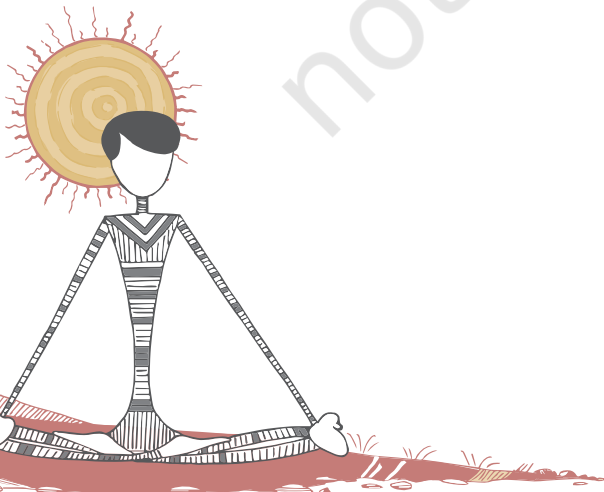

routine demonstrating balance, strength, power, and dynamic motion while preventing the rings themselves from swinging. At least one static strength move is required, but some gymnast includes two or three strengths. A routine should have a dismount at the end of routine.

- (iv) **Vault:** In this, the gymnasts sprint down a runway, which is a maximum of 25 meters in length, before hurdling onto a spring board. The body position is maintained while “punching” (blocking using only a shoulder movement) the vaulting board. The gymnast then rotates to a standing position. Multiple twists and somersaults are added before landing in case of advance gymnastics. Vaults depend on the speed of the run, the length of the hurdle, the power the gymnast generated from the legs and shoulder girdle and the kinesthetic awareness in the air. In case of more difficult and complex vaults the speed of rotation is more important.

- (v) **Parallel Bars:** Men perform on two bars. These are kept slightly further than a shoulder’s width apart and usually 1.75 m high. For executing a series of swings, balances, and releases require great strength and co-ordination.

- (vi) **Horizontal Bar:** A 2.8 cm thick steel or fiberglass bar raised 2.5m above the landing area is all the gymnasts have to hold onto as they perform giants (revolutions around the bar), release skills, twists, and changes of direction. By using all of the momentum from giants and then releasing at the proper point, enough height can be achieved for spectacular dismounts. Leather grips are usually used to help maintain a grip on the bar.

2. Events for women

- (i) **Floor Exercise:** The floor event occurs on a carpeted 12m × 12m square, usually consisting of hard foam over a layer of plywood, which is supported by springs or foam blocks generally called a “spring” floor. Female gymnasts perform a choreographed routine of 50 to 70 seconds in this event. The routine should consist of tumbling lines, series of jumps, dance elements, acrobatic skills, and turns.



Fig. 5.5: Vault

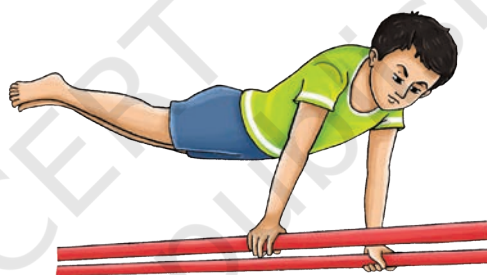

Fig. 5.6: Parallel bars

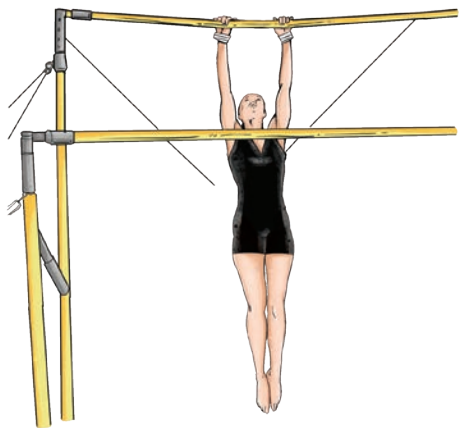

Fig. 5.7: Uneven bars

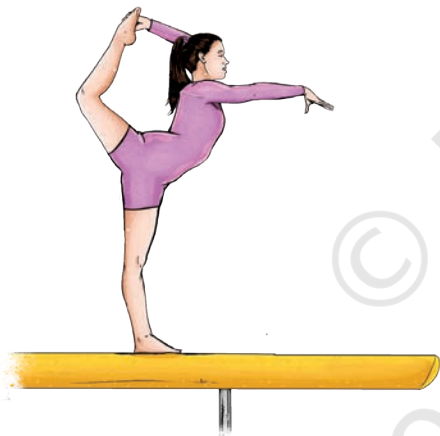

Fig. 5.8: Balance beam

60



- (ii) Vault: In the vaulting events gymnasts sprint down a 25 meters (82 ft) runway, jump onto or perform a round off entry onto a beat board or spring board, land momentarily, inverted on the hands on the vaulting horse or vaulting table. Then they spring off this platform to a two footed landing. Every gymnast starts at a different point on the vault runway depending on her height and strength. The post flight segment may include one or more multiple somersaults, and/or twisting movements. In vaults with round-off entries, gymnasts “round-off” so that hands are on the runway while the feet land on the springboard. From the round-off position the gymnast travels backwards as in a back handspring so that the hands land on the vaulting platform (horse). She then blocks off the vaulting platform into various twisting and somersaulting combinations.
- (iii) Uneven Bars: On the uneven bars (also known as asymmetric bars), the gymnast performs a routine on two horizontal bars set at different heights. The height is generally fixed, but the width may be adjusted. Gymnasts perform swinging, circling, transitional, and release moves, as well as moves that pass through the handstand. Usually in higher levels of gymnastics, leather grips are worn to ensure that the gymnast maintains a grip on the bar, and to protect the hands from blisters and tears.
- (iv) Balance Beam: The gymnast performs a choreographed routine from 70 to 90 seconds in length consisting of leaps, acrobatic skills, turns and dance elements on a padded spring beam. Apparatus norms set by the International Gymnastics Federation specify that the beam must be 125 cm (4') high, 500 cm (16') long, and 10 cm (4.5") wide. The event requires in particular, balance, flexibility and strength.

3. Rhythmic gymnastics

Only women compete in rhythmic gymnastics, although there is a new version of this discipline for men being pioneered in Japan. This combines elements of ballet, gymnastics, dance and apparatus manipulation. The sport involves the performance of five separate routines with the use of five apparatus – Ball, Ribbon, Hoop, Clubs, Rope on a floor area, with a much greater emphasis on the aesthetic rather than the acrobatic.

4. Acrobatic gymnastics

Acrobatic gymnastics is one of the oldest forms of organised physical activities, and today it is being reorganised, revitalised by changes and renewed interest. The International Federation of Sports Acrobatics (IFSA) was founded in Moscow in 1973. United States Sports Acrobatics (USSA) was founded in 1975. It was merged with International Gymnastics federation (FIG) in 1999. Sports Acrobatics was demonstration sports at the 2000 Olympics in Sydney. Now, it is an accepted competitive sport. It is very effective for the development of physical fitness and graceful posture.

Acrobatic gymnastics is a group gymnastic discipline for both men and women. Acrobats in groups of two, three and four perform routines with the heads, hands and feet of their partners. They may, subject to regulations (e.g. instrumental), pick their own music.

5. Tumbling and trampolining

Tumbling, also known as power tumbling, is a gymnastics sporting discipline which combines skills of artistic gymnastics with those of trampolining. It is sometimes practiced on a 25-meter-long spring track, competitors both male and female, perform two passes, each containing eight skills, along the track.

TABLE TENNIS

Table Tennis is also known as Ping-Pong, in which two or four players participate using table-tennis rackets on a plain hard surface called Table, which is divided by a net.

History

The game of Table Tennis probably descended from the game of 'Royal Tennis', which was played in the medieval era (12th century A.D.) Table Tennis was probably played with improvised equipment in England during the last quarter of 19th century. Evidence show that David Foster in England patented an action game of Tennis on Table in 1890. One year later John Jaques came out with a game called Gossima. In 1900, a celluloid ball was introduced by Jaques and the name was given as 'Ping-Pong'. Table Tennis is controlled by ITTF (International Table Tennis Federation) which was founded in 1926 with headquarters in Berlin. It was introduced in Olympics in 1988 in Seoul, South Korea. First World Championship of Table-Tennis was held in London in 1926. TTFI (Table-Tennis Federation of India) was formed in 1926 in Calcutta, now known as Kolkata.

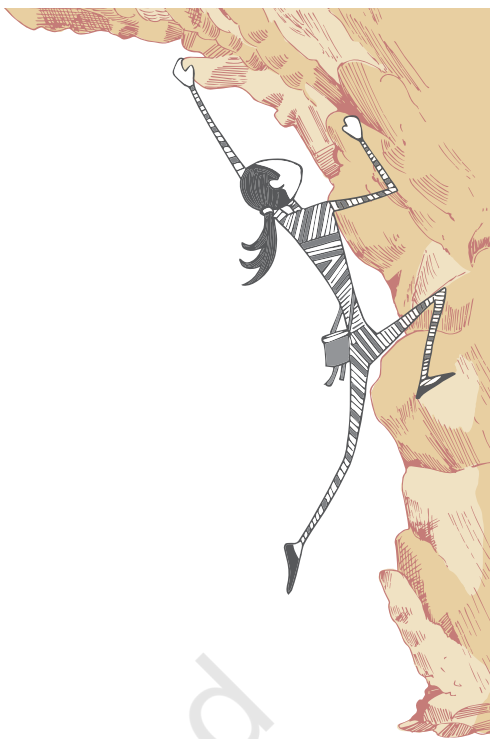

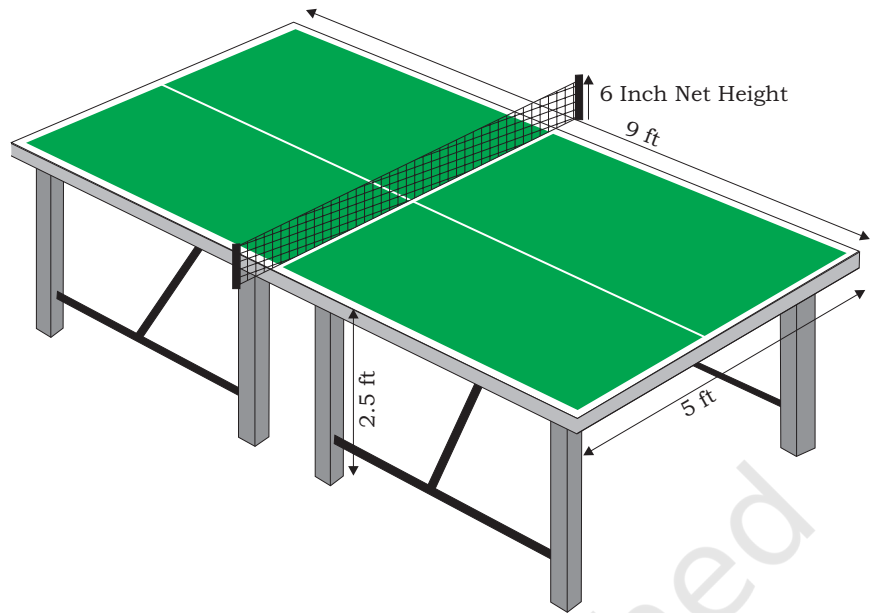

Fig. 5.9: Table tennis

Rules

- Table Tennis table is 9 ft. (2.74 meter) long, 5 ft. (1.525 meter) wide and 2.5 ft.(76 centimeter) high.
- Net is 6 inches (15 centimeter) high from the table.
- A game of Table Tennis is played up to 11 points.
- A player or the pair who first scores 11 points wins unless both players or pairs score 10 points then the game is won by the player or pairs who gains 2 point lead.
- If a player causes the table to move while the ball is in play, player loses a point.
- A player shall score a point if the opponent's free hand touches the playing surface or the net assembly.

Fundamental techniques

1. Grip: Players grip their rackets in a variety of ways. The manner in which players grip their rackets can be classified into two major categories i.e. Pen hold grip (mainly used by Chinese and Korean) and shake hand or Orthodox grip (commonly used).
 - **Pen hold grip:** In this, one grips the racket in such a way as one holds a pen. It involves index finger and thumb joining each other across the handle and curling the middle, ring and fourth finger on the back of the blade. The three fingers however, will always remain touching one another.

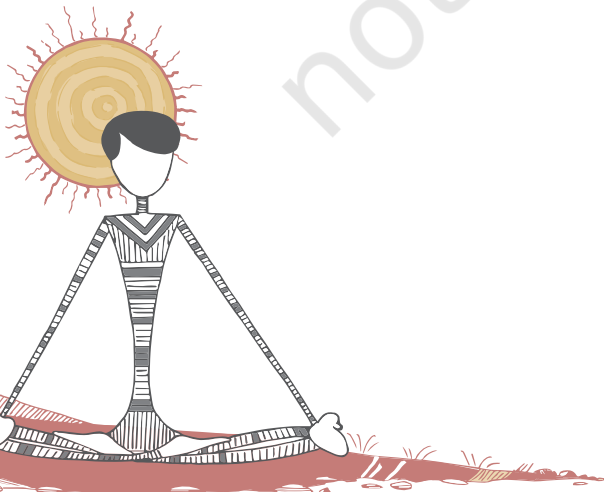



Fig. 5.10: Pen hold grip

- Shake hand grip: In this grip, the racket is held in such a way as one shakes hand with someone. The shake hand grip is used due to increasingly fast nature of the game, making the backhand stroke more effective.
2. Services: There are different kind, of services, such as, long service, short service, spin service, flat service, high toss service and back-hand or forehand service.
 3. Types of strokes: The two types of strokes are offensive and defensive including backhand and forehand.
 - (i) Offensive strokes (drive, loop drive, loop, loop kill, hook, counter drive, flip and smash)
 - a) Drive: The racket is primarily perpendicular to the direction of the stroke, and most of the energy applied to the ball results in speed rather than spin, creating a shot that does not arc much, but it is fast enough to make it difficult to return.
 - b) Loop drive: The racket is much more parallel to the direction of the stroke (closed) and the racket thus grazes the ball, resulting in a large amount of topspin. Variations in spin and speed add to the effectiveness of this shot.
 - c) Loop: The loop produces a more pronounced loopy arc, with a higher trajectory and extreme topspin, but is typically slower.
 - d) Loop kill: The loop kill produces a flatter arc, with higher speed that resembles a speed drive but with stronger topspin.
 - e) Hook: It is similar to a regular Loop, but carries a tilted topspin (or is referred as the “top-side” spin), it bounces sideways and downward upon hitting the table.
 - f) Counter drive: It is a counter attack against drives (normally high loop drives). One has





to bring close to the racket and stay close to the ball (try to predict its path). The racket is held closed and near to the ball, which is hit with a short movement off the bounce (before reaching the highest point) so that the ball travels faster to the other side.

- g) Flip: When a player tries to attack a ball that has not bounced beyond the edge of the table, however the ball may still be attacked, and the resulting shot is called flip because the back swing is compressed into a quick wrist action.
 - h) Smash: Smash is executed when his or her opponent has returned a ball that bounces too high and/ or too close to the net. Smashing is a large back swing and rapid acceleration imparting as much speed on the ball as possible.
- (ii) Defensive strokes
- a) Push or Slice: The push is usually used for keeping the point alive and creating offensive opportunities. A push resembles a tennis slice, the racket cuts underneath the ball, imparting backspin and causing the ball to float slowly to the other side of the table. Offensive players should only push for variation and not for general rallies.
 - b) Chop: A chop or cut is the defensive, backspin counterpart to the offensive loop drive. A chop is essentially a bigger, heavier slice, taken well back from the table. Sometimes a defensive player can impart no spin on the ball during a chop, or frequently add right- or left-hand spin to the ball. This may further confuse his/ her opponent.
 - c) Block: A block is executed by simply putting the racket in front of the ball, the ball rebounds back toward the opponent with nearly as much energy as it came in with. This is not as easy as it sounds, because the ball's spin, speed, and location, all influence the correct angle of a block.
 - d) Side spin drive: The premise of this move is to put a spin on the ball either to the right or the left of the racket. The execution of this move is similar to a slice, but to the right or left, instead of down. This spin will result in the ball curving to the side but bouncing in the opposite direction when the opponent returns it.

- e) Lob: The defensive High Ball or Lob is deceptive in its simplicity. To execute a High Ball, a defensive player first backs off the table 8-10 meters; then, the stroke itself consists of simply lifting the ball to an enormous height before it falls back to the opponent's side of the table. A High Ball is inherently a creative shot, and can have nearly any kind of spin.
- f) Drop shot: The drop shot is a high level stroke, used as another variation for close-to-table strokes. The player has position the racket close to the ball and just let the ball touch it (without any hand movement) in a way that the ball stays close to the net with almost no speed and spin, and touches the other side of the table more than twice if the opponent doesn't reach it.



Skills

Forehand drive

- Keep arm close to the torso.
- Forearm makes 90° with the upper arm.
- Draw the forearm back to another 45°.
- Let the waist turn naturally along with the arm and shift your weight towards the right foot.
- Swing forward with a slight upward motion while shifting your weight back to left foot.
- Elbow should be used as a pivot point and should only move a little forward in the follow through.

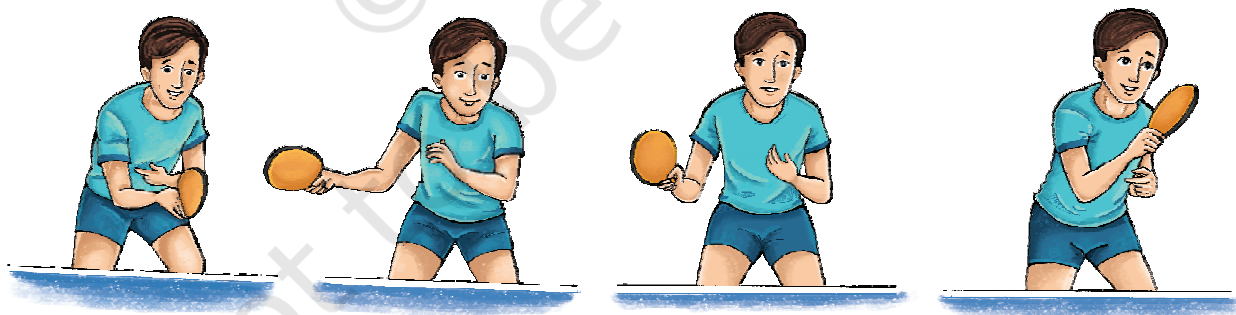

Fig. 5.11: Forehand drive

Backhand drive

- Form ready position.
- Turn waist towards left with Racket towards 9 O'clock position.
- Contact with the ball is made in front of the body slightly after the top of the bounce.

- Elbow acts as pivot point.
- Snap the forearm forward in slightly upward direction.
- Power comes with the flick of the wrist.
- Follow through until the racket points after the ball.

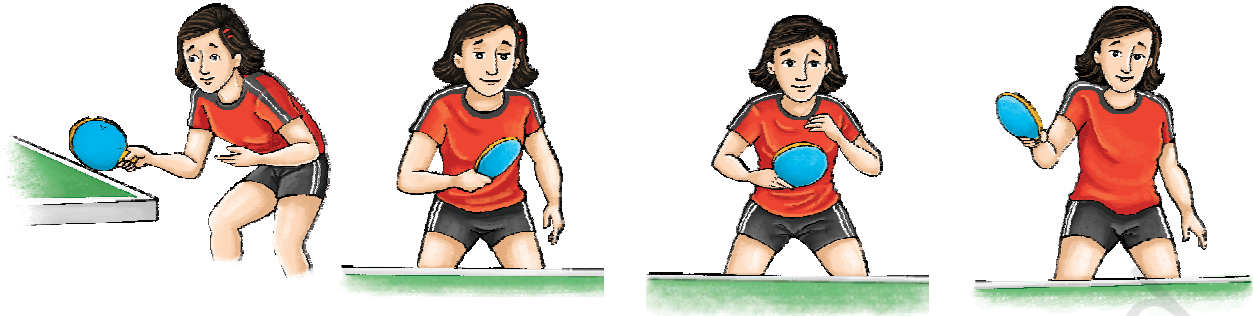

Fig. 5.12: Backhand drive

Blocking

It is a backup shot, when there isn't enough time for a full drive or loop. This stroke allows the players to use opponent force against them.

- Adjust the racket angle according to the severity of top spin. More the spin, more one should close the racket.
- Involve a little backspin and follow through.
- Execute immediately after the bounce to keep control and speed.
- Hit the ball as it is rising off the surface of the table on your side using 50 per cent of the stroke action before hitting the ball and 50 per cent after hitting the ball.

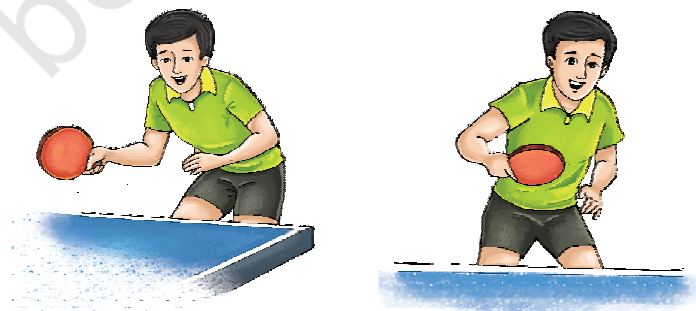
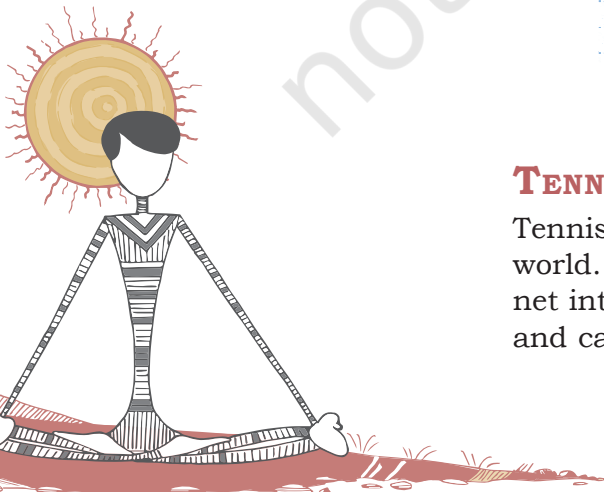

Fig. 5.13: Blocking

TENNIS

Tennis is one of the most popular individual sports in the world. In tennis, the player uses a racquet to hit a ball over a net into the opponent's court. The ball must be kept in play and can only bounce one time on the court surface and the



opponent must strike the ball back over the net. It is a sport usually played between two players (singles) or between two teams of two players each (doubles).

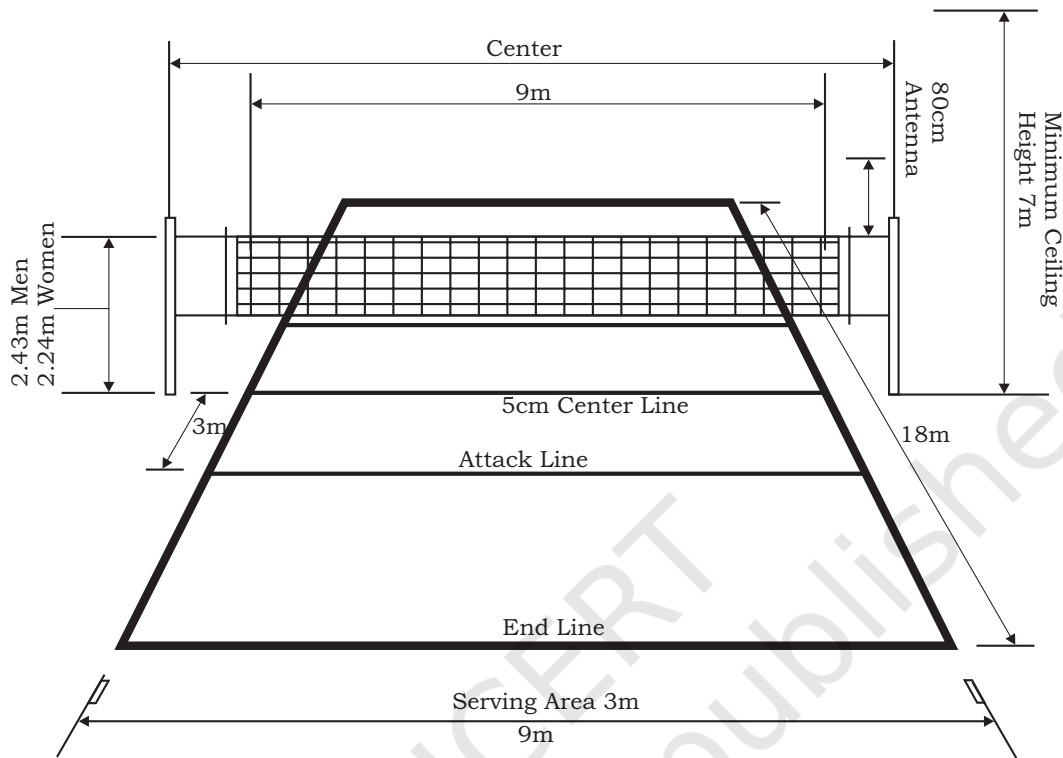

Fig. 5.14: Tennis court

History

An early version of Tennis started in the 16th century in France where players would yell “tenez” when starting a game giving the game the name, Tennis. Later the game was refined in England in the 19th century as lawn tennis which resembled the sport played today. The world’s oldest tennis tournament, the Wimbledon Championships were first played in London in 1877. The comprehensive rules promulgated in 1924 by the International Lawn Tennis Federation, now known as the International Tennis Federation, have remained largely stable, one of the major changes being the addition of the tie-back system. The Davis Cup, an annual competition between men’s national teams, dates to 1900. The analogous competition for women’s national teams, the Fed Cup, was founded as the Federation Cup in 1963. There are four top tournaments called the Grand Slam Tournaments, these are Wimbledon, the US Open, the Australian Open, and the French Open.

Rules

The following are the rules regarding equipment, balls, court, lines and scoring:

1. Equipment

(i) Racquets: Tennis racquet must adhere to the following guidelines —

- The hitting area, composed of the strings, must be flat and generally uniform.
- The frame of the hitting area may not be more than 29 inches in length and 12.5 inches in width.
- The entire racquet must be of a fixed shape, size, weight, and weight distribution. There may not be any energy source built into the racquet.
- The racquet must not provide any kind of communication, instruction or advice to the player during the match.

(ii) Balls: Tennis balls are of hollow rubber with a felt coating. Traditionally white, the predominant colour was gradually changed to optic yellow in the latter part of the 20th century to ensure better visibility.

(iii) Court

- Tennis is played on a rectangular, flat surface, usually grass or clay, a hard court of concrete and/or asphalt and occasionally carpet (indoor). The court is 78 feet (23.77 m) long, and 27 feet (8.23 m) wide for singles matches and 36 ft (10.97 m) for doubles' matches.
- Additional clear space around the court is required for players so as to reach over run balls.
- A net is stretched across the full width of the court, parallel with the baselines, dividing it into two equal ends. The net is 3 feet 6 inches (1.07 m) high at the posts and 3 feet (91.4 cm) high in the center.

(iv) Lines

- The lines that delineate the width of the court are called the baseline (farthest back) and the service line (middle of the court).
- The short mark in the center of each baseline is referred to as either the hash mark or the center mark.



- The outermost lines that make up the length are called the doubles' sidelines. These are the boundaries used when doubles is being played.
- The lines to the inside of the doubles' sidelines are the singles' sidelines and used as boundaries in singles' play. The area between a doubles' sideline and the nearest singles' sideline is called the doubles' alley, which is considered playable in doubles' play.
- The line that runs across the center of a player's side of the court is called the service line because the serve must be delivered into the area between the service line and the net on the receiving side.
- All the lines are required to be 2 inches (51 mm) in width. The baseline can be up to 4 inches (100 mm) wide if so desired.

(v) Scoring

- The players (or teams) start on opposite sides of the net. One player is designated as the server, and the opposing player is the receiver.
- A tennis match is determined through the best of 3 or 5 sets. Women play 3 set matches, while men play 5 set matches. For men, the first player to win three sets wins the match, and for women, the first player to win two sets wins the match.
- A set consists of games, and a game, in turn, consists of a sequence of points played with the same player serving.
- A game is won by the first player to have won at least four points in total and at least two points more than the opponent.
- The running score of each game is described in a manner peculiar to tennis: scores from zero to three points are described as "love", "15", "30", and "40" respectively
- If at least three points have been scored by each player, making the player's score equal at 40 a piece, the score is not called out as "40-40", but rather as "deuce".
- If at least three points have been scored by each side and a player has one more point than the opponent, the score of the game is "advantage" for the player in the lead.

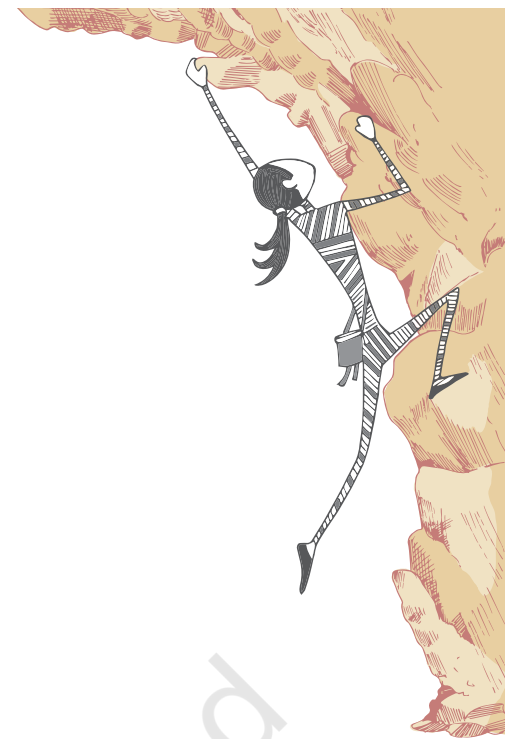



- A game point occurs in tennis whenever the player who is in the lead in the game needs only one more point to win the game. The terminology is extended to sets (set point), matches (match point), and even championships (championship point).
- A break point occurs if the receiver, not the server, has a chance to win the game with the next point. Break points are of particular importance because serving is generally considered advantageous, with the server being expected to win games in which they are serving.
- A receiver who has one (score of 30–40), two (score of 15–40) or three (score of love–40) consecutive chances to win the game has break point, double break point or triple break point, respectively.
- If the leading player wins that game, the player wins the set 7–5. If the trailing player wins the game, a tie-break is played. A tie-break, played under a separate set of rules, allows one player to win one more game and thus the set, to give a final set score of 7–6.
- In tournament play, the chair umpire announces the winner of the set and the overall score.

2. Grip

A grip is a way of holding the racquet in order to hit shots during a match. There are three types of grip.

- Forehand: the tennis forehand is a stroke in which the inner side of the palm of the dominant hand that is holding the racket faces forward. The forehand stroke is made by swinging the racket across one's body in the direction of where one wants to land the ball.
- Backhand: The backhand is a tennis stroke in which one swings the racquet around one's body with the back of the hand preceding the palm.
- The Serve (Service): A serve in tennis is a shot to start a point. A player will hit the ball with racquet so it will fall into the diagonally opposite service box without being stopped by the net. There are three types of serve —
 - Flat Serve
 - Slice Serve
 - Kick Serve

SWIMMING

Swimming is a water based sport where a person propels the body through the water by arms, known as strokes and legs that are called kicks and move progressively through water. It is a sport for all round development of the child. Swimming improves cardiovascular system and places minimum stress on joints. It employs major muscle groups of the body leading to a well-developed flexible muscular system. Swimming is also important for physical rehabilitation for people suffering from disabilities or those recovering from injuries.



Fig. 5.15: Swimming

History

Swimming is a sport that was included in the first modern Olympic Games at Athens in 1896, diving events were added in 1904 and women's competitions were recognised in 1912. FINA (Federation International de Notation) was formed at London Olympic in 1908 AD. National Swimming Association of India was founded in 1949. Swimming was one of the six sports at the First Asian Games held at Delhi in 1951. The aquatic sport of swimming involves competition amongst participants to be the fastest over a given distance. Different distances are covered in different levels of competition.

Rules

- A swimmer must finish the race in the same lane. Swimming across another lane or interfering with the other shall disqualify the offender.
- During a turn the swimmer shall touch the end of the pool.
- A swimmer should not walk.
- Any swimmer not participating in a race, who enters the water in which an event is being conducted before all swimmers shall be disqualified from the next scheduled race in the meet.

Do You Know?

The current Olympic games contain freestyle events of 50m, 100m, 200m, 400m, 800m, and 1500m; 100m and 200m events in each of backstroke, breaststroke and butterfly; 200m Individual Medley (that is, 50m butterfly, 50m backstroke, 50m breaststroke, and 50m freestyle); 400m Individual Medley (100m butterfly, 100m backstroke, 100m breaststroke, and 100m freestyle); and the Marathon 10km.

- There shall be four swimmers in each relay team. In relay events, the team of swimmers whose feet lose touch with the starting platform before the preceding teammate touches the wall shall be disqualified. Any relay team shall be disqualified from a race if a team member, other than the swimmer designated to swim that length, enters the water when the race is being conducted, before swimmers of all teams have finished the race. The member of a relay team and their order of competing must be nominated before the race. Any relay team member may compete in a race only once.
- The composition of a relay team may be changed between the heats and finals of the event, provided that it is made up from the list of swimmers properly entered by a member for that event. Failure to swim in the order listed will result in disqualification. Substitutions may be made only in the case of a documented medical emergency.
- Any swimmer having finished the race, or the stipulated distance in a relay event, must leave the pool as soon as possible without obstructing any other swimmer who has not yet finished the race. Otherwise the swimmer committing the fault or the relay team shall be disqualified.
- Should a foul endanger the chances of success of a swimmer, the referees shall have the power to allow the swimmer to compete in the next heat or, should the foul occur in a final event or in the last heat, they may order it to be re-swim.

Fundamental techniques

Techniques in swimming are strokes, starts and turns.

Strokes

In swimming there are four competitive strokes (Front Crawl, Back Crawl, Breast stroke and Butterfly stroke) being followed all over the world. All the above mentioned strokes have been learnt in the previous class.

Starts

All four competitive strokes are to be started in the competition by using the technique known as start. The swimmers emphasis on the quickest technique, which allows him a stronger push off from the starting position. The starting techniques, popular today, are: (i) Grab start (ii) Circular start (iii) Racings start (iv) Conventional start (v) Tuck start. The following sequence is followed; (i) Position on the block (ii) Take off (iii) Flight (position in air) (iv) Entry into the water

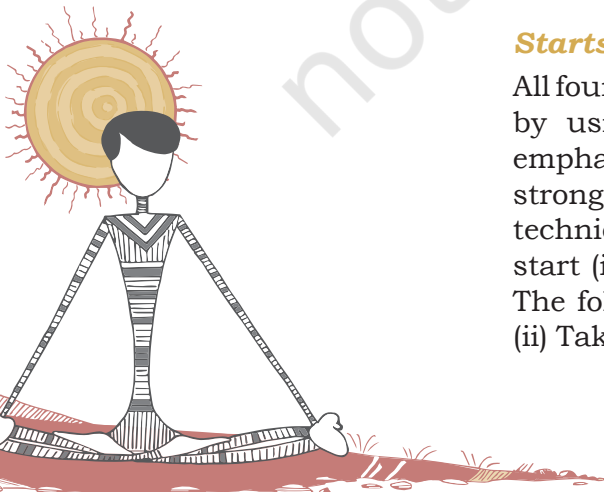

(v) Glide (vi) First stroke. However, backstroke uses almost a uniform technique, which does not have any special name and is known as backstroke start.

Turns

During the race, the swimmer must take a turn from the end of the wall to complete the full distance. The swimmers try to use a technique that is quicker and gives a strong push off from the wall within the permissible rules of the stroke. The various turns used by swimmers are: (i) Simple turn (ii) Throw away turn (iii) Summer Sault turn (iv) Flip turn (v) Roll over turn (vi) Breast stroke turn (vii) Butterfly turn. The following sequence is followed in the turn: (i) Approach to the wall (ii) Turn or touch (iii) Push off (iv) Glide (v) First stroke.

Tactics

Swimming is an individual and cyclic sport. It is highly competitive with the application of science. It is getting transformed from an art to science. Now, the importance is given to strategy and tactics for completing and pacing the race. In order to achieve the best performance, a swimmer must learn to distribute the distance economically and thoughtfully throughout the race. Tactics in swimming during different races can be categorised in three different phase — (i) Sprint races (ii) Middle distance races (iii) Long distance races

Sprint races

The 50 m race or the sprint race depends on the start, maintaining the speed and a good finish.

Middle and Long distance races

In these races, the key word is to build endurance and speed. In middle and long distance races, the swimmer tries to prevent building up high oxygen debt. Swimming at a very fast pace will accumulate a high level of oxygen debt early in the race and will experience an immediate drop in speed. Swimmer may sometimes prefer to begin faster than an ideal pace and attempt to get out in front avoiding the choppy waters. Some swimmers like to swim the strategy races in relation to the opponent.



ASSESSMENT

BADMINTON

I. Answer the following Questions

1. What are the types of events in Badminton?
2. Which motor skill do you enjoy the most and why during a game of badminton?
3. Explain the badminton technique you like most. Why?

II. Fill in the Blanks

1. Measurement of Badminton court for singles is _____.
2. Height of the poles from the floor is _____.
3. Weight of the shuttle cock is _____ to _____.
4. Number of feathers in a shuttle cock are _____.

III. State whether True or False

1. Four players are required to start a game.
2. International Badminton Federation was founded in 1934.
3. Player can leave the court at any time.
4. Breadth of badminton net is 2'6".

GYMNASTICS

I. Answer the following Questions

1. What is the difference between gymnastics events for men and women?

II. Fill in the Blanks

1. Rhythmic Gymnastics was included in Olympic games in _____ at _____.
2. Measurement of floor for floor exercises is _____ metre.
3. Length of balancing beam is _____.
4. Gymnastic team consists of _____ players.
5. A official can wait for _____ minutes, if a player has not arrived in time.

III. State whether True or False

1. Uneven bar is a men's event.
2. Balancing beam is a women's event.

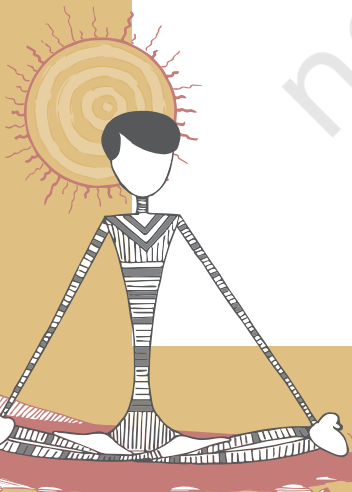

3. Pommel horse is a men's event.
4. Parallel bar is a men's event.
5. International Gymnastic Federation was founded in the year 1881.

TABLE TENNIS

I. Answer the following Questions

1. Which motor skill did you enjoy the most in table tennis game and why?
2. Give three landmarks in the development of table tennis.
3. Define the terms, drive and smash as used in table tennis.
4. Write in brief the history of table tennis.
5. List the equipments required in table tennis.

II. Fill in the Blanks

1. The table used in table tennis is _____ feet long _____ feet wide and _____ feet high.
2. Net is _____ inches high from the table.
3. A game of table tennis is played up to _____ points.
4. A player or the pair who first scores 11 points wins unless both players and pairs score _____ points. Then the game is won by the player or pairs who game a 2 point lead.
5. If a player causes the table to move whilst the ball is in play, player _____ a point.
6. A player shall score _____ if his opponent's free hand touches the playing surface or the net assembly.

TENNIS

I. Answer the following Questions

1. When does a game point occur in tennis?
2. What is a break point in tennis?
3. How is the scoring done in a tennis match?

II. Fill in the Blanks

1. The frame of the hitting area may not be more than _____ inches in length.
2. Tennis balls are of hollow rubber with a felt coating. Traditionally white, the predominant color was gradually changed to _____.
3. The tennis court is _____ feet long and _____ feet wide for singles matches.

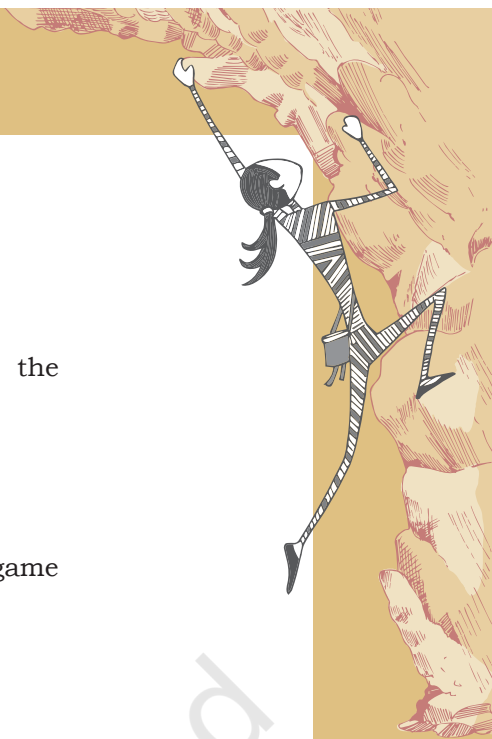

- The lines that delineate the width of the court are called the _____.
- A tennis match is determined through the best of 3 or 5 sets. Women play _____ set matches, while men play _____ set matches.

SWIMMING

I. Answer the following Questions

- Which stroke is the slowest?
- List down the diving events of men and women?
- Explain the technique of any stroke of your choice?

I. Fill in the Blanks

- Standard swimming pool should be of _____ mts. length and _____ mts. width.
- There are _____ lanes in standard swimming pool.
- Width of lane is _____.
- Height of starting platform is _____.

II. State whether True or False

- A swimmer can change the lane after start.
- The fourth lane is given to the best swimmer.
- Roll over turn is permitted in backstroke.

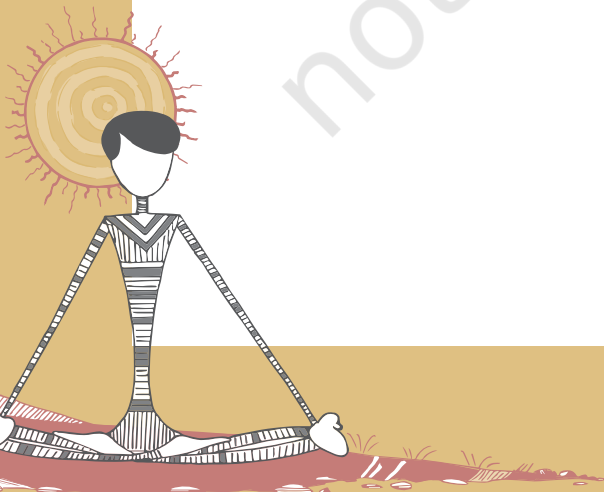

6

TEAM GAMES AND SPORTS I



A team game means organised physical activity with players working together towards a shared objective. In team games a group of individuals in the same team, work together to achieve the objective of being the winners of the game. Team members set points and scores, make decisions, communicate among themselves, manage conflicting situations, and solve problems in a supportive, trusting atmosphere in order to achieve their objectives. Team games include games, such as, Basketball, Cricket, Football, Handball, Hockey, Kabaddi, Kho-Kho and Volleyball, etc. In this chapter, we shall discuss Basketball, Cricket, Football, Hockey and Volleyball.



1077CH06

BASKETBALL



Fig. 6.1: Children playing basketball

Basketball is a fast, free-flowing, high-scoring team game. The players shoot a ball through a basket to score points while following a set of rules. Usually, two teams consist of

five players on each team. They play on a marked rectangular court with a basket fixed on each end. Basketball is one of the world's most popular games.

The rules allow all players to move freely around the court and occupy any position. All players have an equal opportunity to score a Basket. To play basketball, students should learn and practice the basic skills of dribbling, passing, receiving and shooting.

History

The game of basketball originated at the Springfield College of Physical Education, Massachusetts, USA in 1891, invented by Dr. James Naismith. In 1894, Naismith fixed the first 13 rules which still form the basis of modern basketball. In India, the Young Men's Christian Association (YMCA) at Kolkata introduced basketball for the first time. Later the YMCA established at Madras in 1920 played an important role in the development of this game. Today basketball is one of the most favourite games in many schools and colleges. The game is played by both men and women of all ages and ability. In order to promote Basketball at National and International levels the Basketball Federation of India was set up in 1950. The first National Basketball tournament was held in Delhi in 1934 and thereafter it was organised every two years until 1951. After that it started being organised annually.

Basketball court measurements

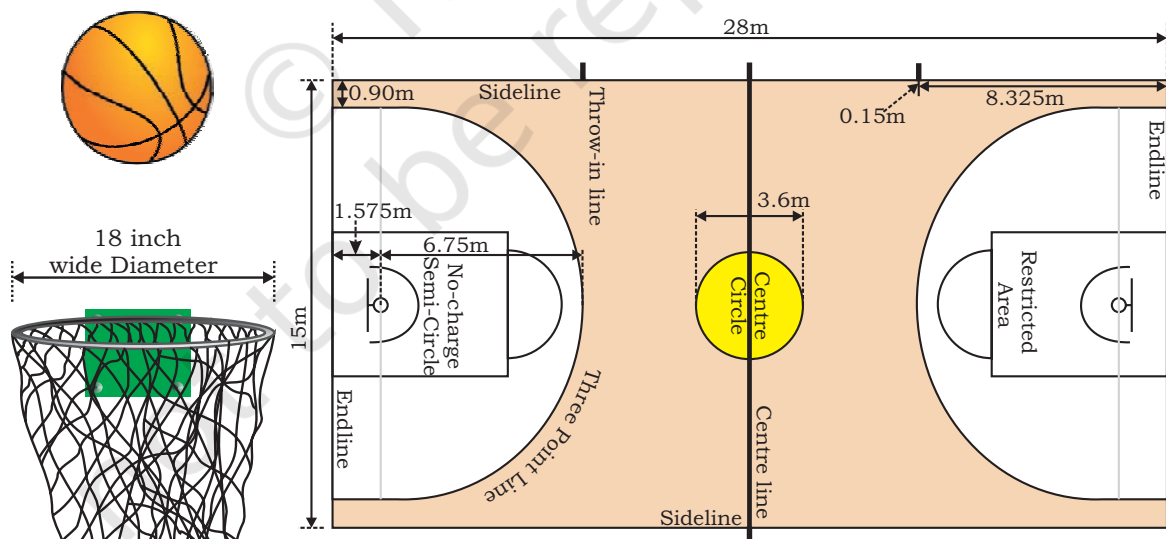

Fig. 6.2: Basketball court, a basket and a basketball

Basketball is played on a rectangular court, which should be an indoor wooden court or an outdoor concrete court having two side lines and two end lines. The dimensions of basketball court is 28 x 15 meters. The court is divided

into two sections, called half-courts, by the mid-court line, which is where the game starts with a jump ball. A jump ball is when a referee throws the ball up at center circle to determine which team gets possession. Two players from opposing teams jump up to tap the ball out of the circle in order to gain control over the ball take the game forward. The basketball posts are located at the opposite ends of the court.

Rules

Duration of a Match (Total 4 Quarters)						
Play	Rest	Play	Half time	Play	Rest	Play
10 min	2 min	10 min	15 min	10 min	2 min	10 min

- The duration of the game of each quarter is ten minutes with 2 minutes rest between 1st and 2nd quarter and 3rd and 4th quarter, also 15 minutes rest between 2nd and 3rd quarter. Extra time period is of about 5 minutes. Teams exchange the side after half time. The clock is stopped while the play is not active. Therefore, it takes longer time to complete the game than the allotted time.
- A team must consist of twelve (12) members. But only five players from each team may be on the court at one time. Substitutions are unlimited but can only be done when the play is stopped.
- The team with the ball, attempting to score in their basket is 'on offense', the team that prevents opposite team from scoring is 'on defence'. The ball is moved in two ways: either dribbling or by passing to teammates. If the ball goes out of the court, the ball possession is given to the opposite team.
- For both men's and women's teams, a standard uniform consists of a pair of shorts and a jersey with a clearly visible bib number, printed on both the front and back. Players should wear appropriate shoes that provide extra ankle support.
- The game is controlled by the officials consisting of the three (3) referees, out of which one (1) is the overall incharge and the other four (4) table officials are responsible for keeping other records of each teams scoring, timekeeping, individual and team fouls, player substitutions, alternating possession arrow, and stop-and-go-clock, etc.
- The essential equipment in basketball game is the ball, clocks, score sheets, scoreboard(s), alternating possession arrows and other required equipments.
- An attempt to unfairly disadvantage an opponent through physical contact is illegal and called a foul.

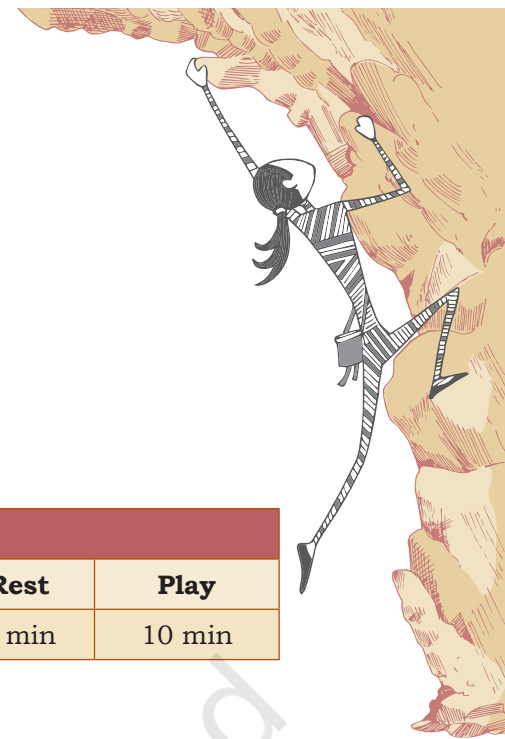



Fig. 6.3: Dribbling

Players who are fouled either get ball possession or are awarded one or two free throws and one point is awarded for successfully converting a free throw, which is attempted from a line 15 feet (4.6 m) from the basket. Each player is allowed 5 personal fouls before they are disqualified from the game. At this point they no longer remain a part of the game.

- Two points are awarded when a basket is scored during the game but three points are awarded when a basket is scored from outside the 6.25 mtrs line.

Fundamental skills

We are well aware that, to play any game one has to learn some skills. Similarly to play basketball game a player should learn the following fundamental skills.

Dribbling

It is important to penetrate to score a basket, move the ball across the court, get away from the defenders, and find a good passing lane. There are different types of dribbling —

- basic dribble
- low dribbling
- high dribble
- behind the back
- crossover dribble
- change-of-pace
- between the legs dribble

Passing

A good offensive attack requires accurate passing from players. It helps find an open man, to find a good shooter or to get away from a defender. There are several types of passes used in basketball, either one hand or both hand pass —

- Overhead
- Chest
- Push
- Baseball
- Off-the-dribble
- Bounce
- Shoulder
- Hook

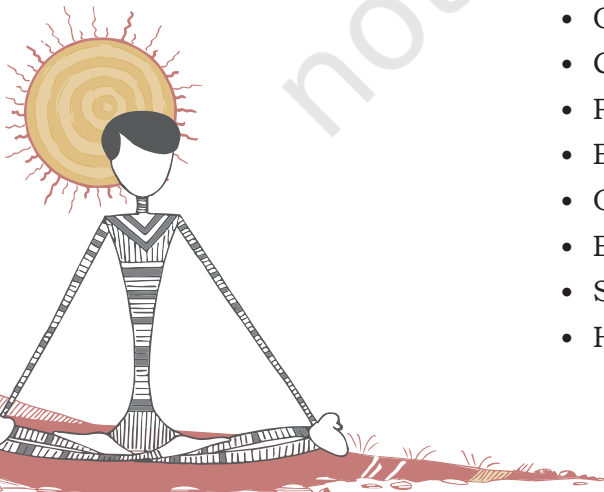

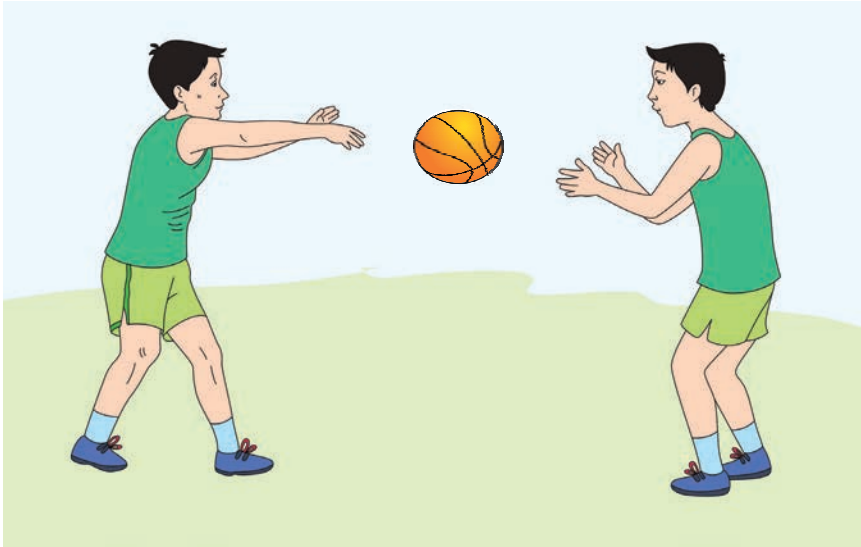

Fig. 6.4: Passing

Shooting

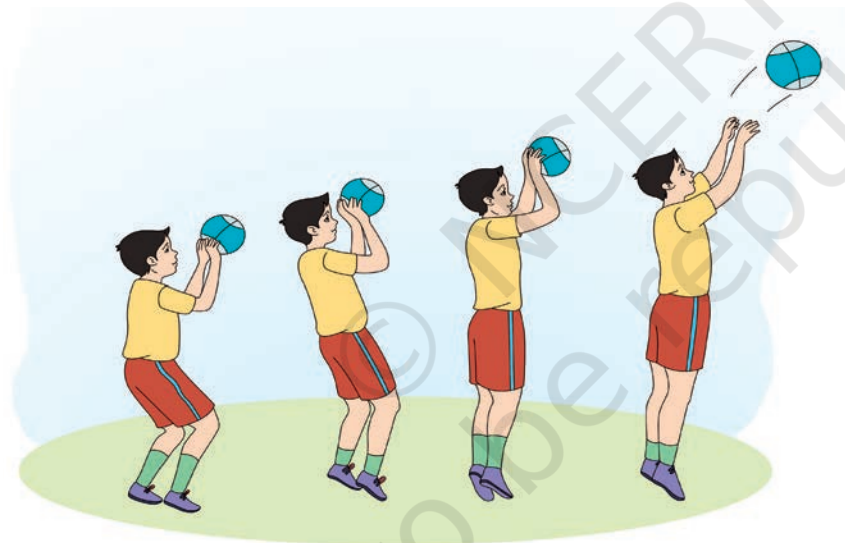
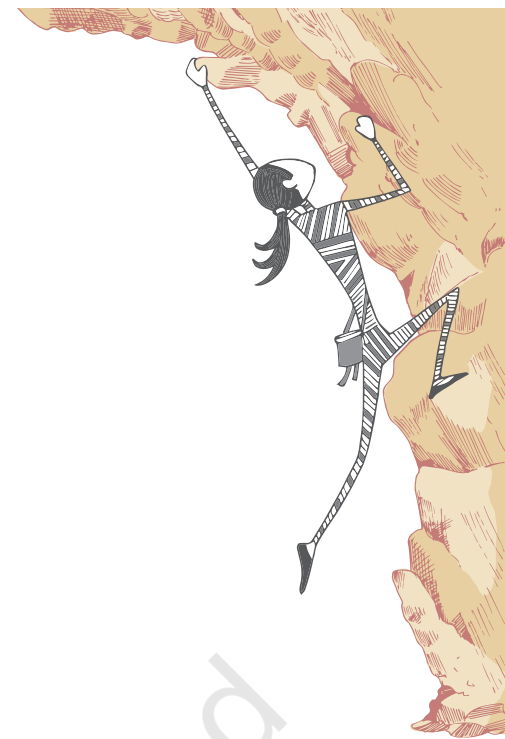

Fig. 6.5: Shooting

The objective of the game is to win by scoring maximum points. Therefore, improving the team's shooting is important to win a game. Shooting with either one hand or both hands is done in the following ways —

- Jump shot
- Dunk shot
- Free throw
- Layup
- Three-point shot
- Hook shot



Defence



Fig. 6.6: Defence

The game of basketball allows a variety of defences to be deployed in an effort to disrupt and combat offensive plays. Here are examples of the three basic categories of team defences. In addition, each category comprises of an assortment of different variations.

- *Man to man defence:* Man-to-man defences match up the defenders against specific offensive players. Defenders are usually assigned to be matched up with offensive players by size and ability.
- *Zone Defence:* In Zone defence, defenders are assigned to guard specific areas on the court. Zones are named or designated by their player alignments.
- *Combined Defence:* A third type of defence that can be deployed is the combination defence. With combination defences, some of the players are assigned to play man-to-man while the rest of the defenders play zone. Combination defences are usually deployed in an effort to stop or neutralise great individual offensive players.

Rebounding

The objective of rebounding is to successfully gain possession of the basketball after a missed field point or free throw, as it rebounds from the ring or backboard. This plays a major role in the game, as most possessions end when a team misses a shot. There are two categories of rebounds: offensive rebounds, in which the ball is recovered by the offensive side and does not change possession, and defensive rebounds, in which the defending team gains possession of the loose ball. The majority of rebounds are defensive, as the team on defence tends to be in better position to recover missed shots.

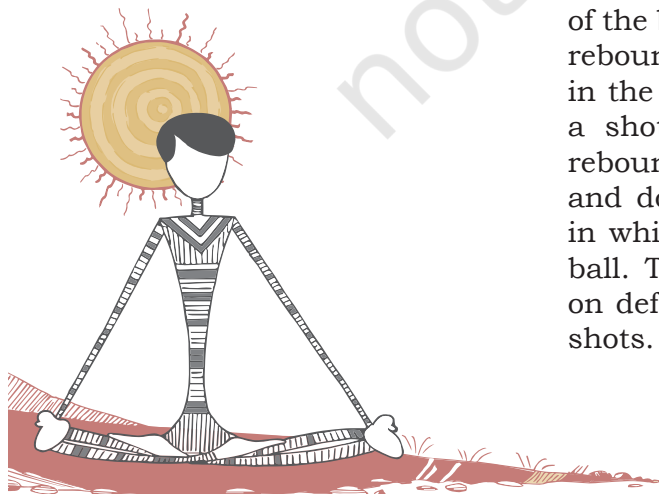



Fig. 6.7: Rebounding

Arjun awardees

S.No.	Name of Player	Year
1.	Sarbjit Singh	1961
2.	Man Mohan Singh	1971
3.	Suman Sharma	1983
4.	Parminder Singh	2001
5.	Geethu Anna Jose	2014
6.	Prashanti Singh	2017

CRICKET

Introduction

Cricket is a bat and ball game played between two teams on a field, at the centre of which is a rectangular pitch. One team bats, trying to defend the wicket and scoring as many runs as possible. The other team bowls and fields, trying to dismiss the batsmen and thus limiting the runs scored by the batting team. A run is scored by the striking batsman hitting the ball with his bat, running to the opposite end of the pitch and touching the crease there without being dismissed. The teams switch between batting and fielding at the end of an inning.



History

The game of cricket, as it is played today, has its origin in the south eastern part of England. Cricket became a generally adopted sport in the second half of the seventeenth century. The Hambledon club which was founded in about 1750's had played a significant part in the evolution of the game. It was superseded by the Marylebone Cricket Club (M.C.C) with its headquarters at Lords, London. Cricket became an international game with the formation of the Imperial Cricket Conference (I.C.C) in 1909. The name of Imperial Cricket Conference was changed to International Cricket Conference (later, Council) to enable countries outside the common wealth to become its members. The first Limited Over International cricket match was played in 1971 at Melbourne. The governing International Cricket Council (ICC) saw its potential and staged the first limited over Cricket World Cup in 1975. The first edition of limited over Cricket world cup won by West Indies.

In the 21st century, a new limited over form, Twenty 20, has made an immediate impact. The first T-20 international match took place on August 5 2004, between the women's teams of England and New Zealand. The first T-20 international match between men's teams was played on February 17 2005, between Australia and New Zealand. The first T-20 World Cup was played in South Africa in 2007. India won the first edition of T-20 World Cup.

An all India team went on a tour of England in 1911 under Maharaja Bhupinder Singh of Patiala. The Indian Cricket Control Board came into being towards the end of 1928. The national championship for the Ranji Trophy began in 1935. India entered the international arena and played its first official Test against England in 1932. Meanwhile Prince Ranjit Singhji of Nawanagar who had gone to England for further studies, made a remarkable name for himself in the game of cricket.

Measurement

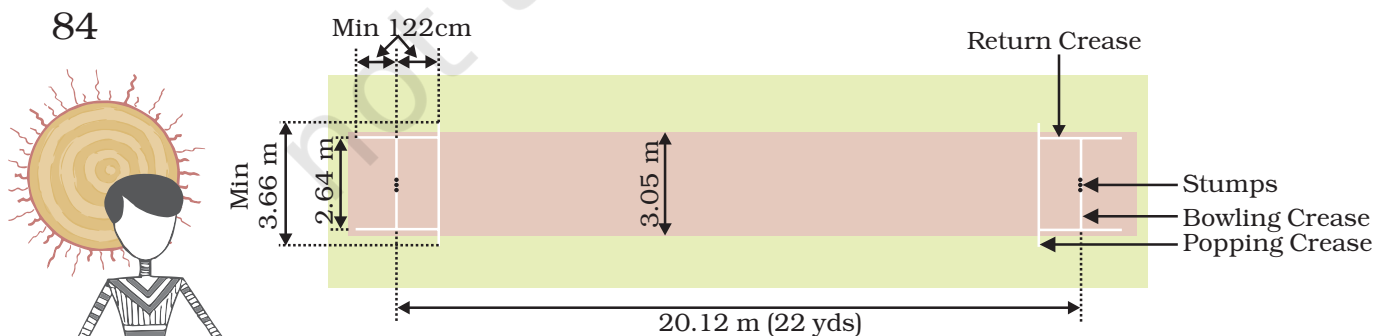

Fig. 6.8: Specifications of cricket ground

Ways to score runs

The aim of the batsmen is to score runs. One of the main cricket rules for batsmen to score runs is that they must run to the pitch at each other's end (from one end to the other), hence score one run. Cricket rules state that, they may run multiple runs per shot. As well as while running they can also score runs by hitting boundaries. A batsman hits a boundary and scores 4 or 6 runs. A four and six both are scored by hitting the ball. If it crosses the boundary after touching the ground it is considered as four and if the ball crosses boundary before touching the ground it is considered as six. Cricket rules also state that once a 4 or 6 has been scored any runs physically scored by the batsman by running between the wickets are null and void.

Other ways runs can be scored according to the cricket rules include no balls, wide balls, byes and leg byes. Cricket rules state that all runs scored by these methods are awarded to the batting team but not the individual batters.

- A **No Ball** can be declared for many reasons: If the heel of the bowler's front foot lands on or in front of the popping crease or if the bowler's back foot touches then outside the return crease the ball is declared no ball. If the bowler bowls the ball from the wrong place, the ball is declared dangerous (often happens when bowled at the batsmen's body on the full), bounces more than twice or rolls before reaching the batsman or if fielders are standing in illegal positions. The batsman can hit a No ball and score runs off it but cannot be out from a No ball except if they are run out, hit the ball twice, handle the ball or obstruct the field. The batsman gains any runs scored off the no ball for his shot while the team also gains one run for the no ball itself.
- A **Wide Ball** will be declared if the umpire thinks the batsman did not have a reasonable opportunity to score off the delivery. However if the delivery is bowled over the batsmen's head it will not be declared a wide but a no ball. Umpires are much stricter on wide deliveries in the shorter format of the game while being much more relaxed in test cricket. A wide delivery will add one run to the batting team and any runs scored by the batsman. The batsman is not supposed to be declared 'out' off a wide delivery except if they are stumped, run out, handle the ball, hit their wicket or obstruct the field.
- A **Bye** is where a ball that isn't a no ball or wide passes the striking batsman and runs are scored without the batsman hitting the ball.

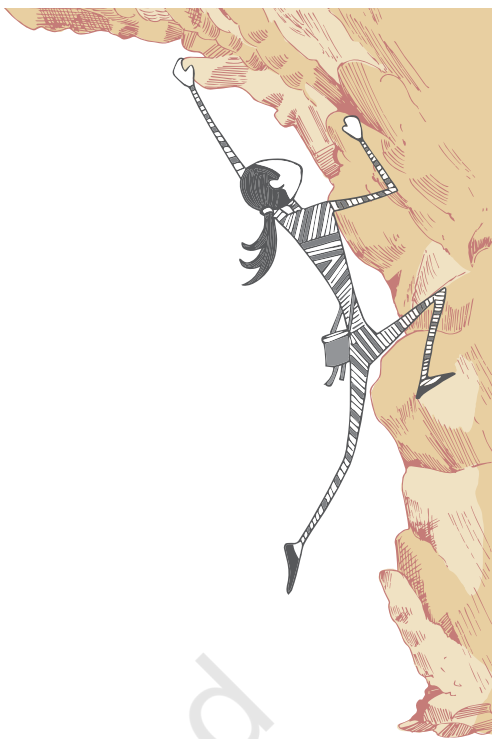

- A **Leg Bye** is where runs are scored by hitting the batsman, but not the bat and the ball is not a no ball or wide. However no runs can be scored if the striking batsman didn't attempt to play a shot or if he was avoiding the ball.

Types of 'out' in cricket

Ways batsmen can be given 'Out' according to cricket rules: There are a number of different ways a batsman can be given out in the game of cricket. When a bowler gets a batsman out it is said that the bowler gets a 'wicket'. Following are the different ways, a batsman can be given out according to the rules of cricket:

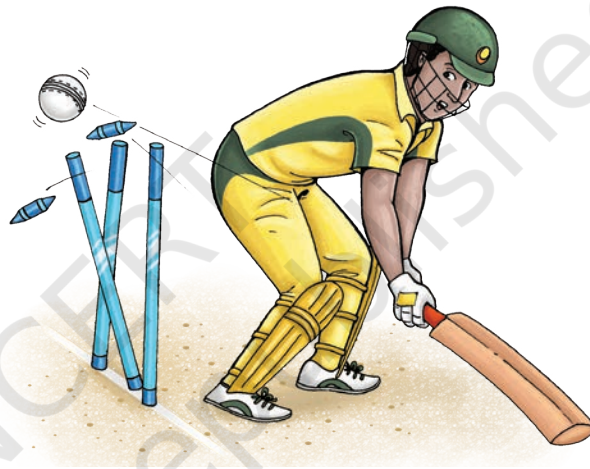
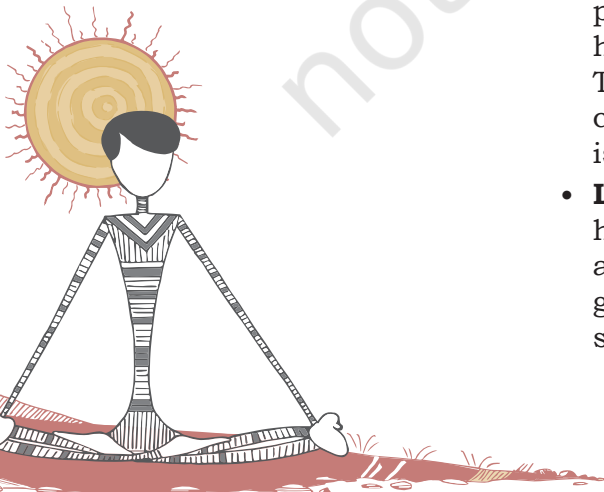

Fig. 6.9: Bowled

- **Bowled** – Cricket rules state that if the ball is bowled and hits the striking batsman's wickets the batsman is given out (as long as at least one bail is removed by the ball). It does not matter whether the ball has touched the batsman's bat, gloves, body or any other part of the batsman. However, the ball is not allowed to have touched another player or umpire before hitting the wickets.
- **Caught** – Cricket rules state that if a batsman while playing the ball, either it touches his bat, hand or glove holding the bat then the batsman can be caught out. This is done by the fielders, wicket keeper or bowler catching the ball on the full (before it bounces). If this is done then cricket rules state the batsman is out.
- **Leg before Wicket (LBW)** – If the ball is bowled and hits the batsman first without touching the bat, then an LBW decision is possible. However for the umpire to give this out he must first look at some of the factors stated in the cricket rules. The first thing the umpire



need to decide is that if it is not a no ball, would the ball have hit the wickets if the batsman was not there. If his answer to this is yes and the ball was not pitched on the leg side of the wicket he can safely give the batsman out. However, if the ball hits the batsman outside the line of off stump while he was attempting to play a stroke then he is not out.

- **Stumped** – A batsman can be given out according to cricket rules when the wicketkeeper puts down his wicket while, he is out of his crease and not attempting a run (if he is attempting a run it would be a run out).
- **Retired Out** – A batsman leaves the field without the permission of umpire for any resource like, illness, injury etc. Then is given as retired out.
- **Run Out** – Cricket rules state that a batsman is out if no part of his bat or body is grounded behind the popping crease while the ball is in play and the wicket is fairly put down by the fielding side.
- **Hit Wicket** – Cricket rules specify that if a batsman hits his wicket down with his bat or body after the bowler has entered his delivery stride and the ball is in play then he is out.
- **Handled the Ball** – Cricket rules allow the batsman to be given out if he willingly handles the ball with the hand that is not touching the bat without the consent of the opposition or umpire.
- **Timed Out** – An incoming batsman must be ready to face a ball or be at the non strikers end with his partner within three minutes of the outgoing batsman being dismissed. If this is not done the incoming batsman can be given timed out.
- **Hit the Ball Twice** – Cricket rules state that if a batsman hits a ball twice other than for the purpose of protecting his wicket or with consent from the opposition, he is out.
- **Obstructing the Field** – A batsman is out if he intentionally obstructs the opposition by word or action

There are many other cricket rules. However these are most of the basics and will get you well on your way to playing the game. Many of the more advanced rules and laws can be learned along the way and are not vital to general play.

If any batsman leaves the field of play without the Umpire's consent for any reason other than injury or incapacity, he may resume the innings only with the consent of the opposing captain. If he fails to resume his innings, he is out. For the purposes of calculating a batting average, retired out is considered a dismissal.



Rules

- Cricket is a game played between two teams consisting of eleven players each. There is also a reserve player called a twelfth man, who can only be utilized as fielder.
- The twelfth man is not allowed to ball, bat, and wicket keeping or captain the team. His sole duty is to act as a substitute fielder.
- Two umpires are placed on the playing field while there is also a third umpire off the field who is in charge of video decisions.
- When the call is too close for the on field umpires then they refer it to the third umpire who reviews slow motion video replays to make a decision.

Fundamental skills

Batting skills

Being a batsman he must have good wrist power, eye co-ordination, Endurance, speed, Excellent reaction ability and Statistics for cricket.



Fig. 6.10: Batting skill



Batting techniques

- Defence
- Pull
- Hook
- Drive
- Cut
- Sweep

Front foot defence

- The front foot defence is played when the ball is bowled at a good length, which is not over-pitched enough for a drive and not short enough to go on the back foot.
- The front foot should move as close as possible to the pitch of the ball with the left shoulder and left elbow leading the body in the direction of the ball.
- The weight of the body is on the front foot with the knee bent and the head should be over the bat watching the point of contact. The bat is kept angled and very close to the front pad to prevent the ball going through bat and pad.
- The top hand is firm at the top of the handle while the bottom hand is relaxed, with the thumb and index finger loosely holding the bat. The back leg should be fully extended with the heel raised off the ground but remaining parallel to the crease.
- The weight of the back foot should be on the inside of the right toe and care should be taken not to turn it or drag it out of the crease.
- The front foot defensive stroke can be played with the bat slightly behind or in front of the pad depending on the nature of the wicket and the proficiency of the bowler.

Off drive

- Off drive is played to an over-pitched ball in line with the off stump or marginally outside.
- Like the forward defence, the left shoulder and elbow lead the body with the front foot going as close as possible to the pitch of the ball. The bat comes down in an arc from the top of the back lift and strikes the ball just in front of the left foot.
- After impact, the bat must continue in the arc and finish over the left shoulder. The follow through can also be checked at shoulder height, keeping the bat face open.
- The head is kept straight and still throughout the shot and the top hand and elbow controls the direction of the shot. At the time of impact the head should be over the ball with the body weight balanced on the front foot. The full face of the bat must hit the ball and on completion, the batsman must be well balanced.





Fig. 6.11: Bowling Skills

Straight drive

- This shot is played exactly in the same way as an off drive but with the difference is that it is played to a over pitched ball in and around the line of middle stump and the front foot must point down the wicket and the body must be turned slightly and the shoulders opened out to allow the free swing of the bat.

On drive

- On drive is played to a over-pitched ball on and around the leg stump.
- This has been considered to be a difficult shot to play. The basic principles of a drive apply here too, though the swing of the bat is an arc from slips to mid- on with the front pointing down the wicket.
- The front foot should be placed outside the line of ball with the shoulders turned and the impact is just in front of the left toe. The follow through is generally checked below shoulder height.

Back foot defence

- The back foot defensive stroke is played to a short-pitched ball in line with the stumps, which is not short enough to play and attacking shot.
- The back foot is moved back and across to the line of the ball with the front naturally following it. The bat is brought down close to the body with the head steady and over the ball.
- The back foot must remain parallel to the crease as far as possible to maintain the sideways position of the body with the top hand firm and in control, and the bottom hand holding the bat loosely.
- To keep the bat straight, the left elbow is held high next to the head. Care should be taken to maintain the balance at the time of playing the ball and to remain 'side-on' as this presents a smaller target for short rising deliveries.
- The back foot defence can also be played with the body beside the line of the ball, but here the batsman must resist the temptation to follow the movement of the ball away from him.

Bowling skills

Bowling is as important as batting. The ball is defended by a batsman to save his wicket. When the ball is bowled to a batsman it is called as a ball or delivery.

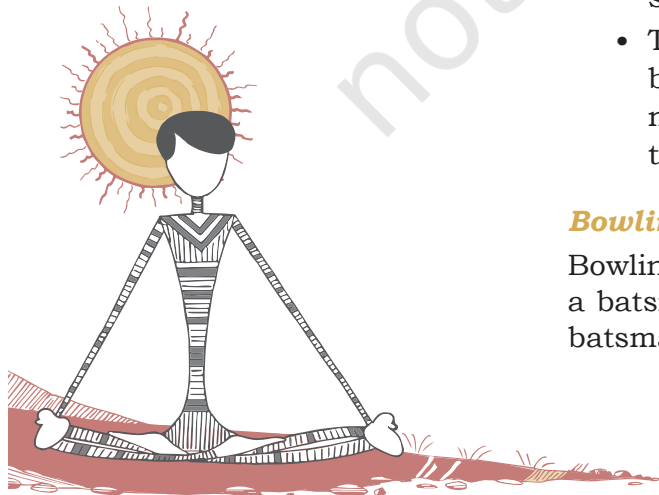

Types of bowling

Fast bowling	Spin bowling
Seam bowling	Off spin
Swing bowling	Leg spin
Bouncer	Chinaman
In swinger	Doosra
Leg cutter	Googly
Off cutter	Arm ball

Swing bowling

- When a ball of a fast or medium fast bowler deviator in air either on leg side (in swing) or on off side (out swing) it is turned in air as swing bowling.

Outswing

- For out swing bowling, the ball is held with the index and middle finger and thumb below the seam, which is upright & angled towards the slips with the shiny surface on the right (for right hand bowler).
- For effective out swing bowling, the bowler should bowl as close as possible to the stumps.
- The wrist is cocked and when the ball is released the seam must be vertical and goes down the pitch upright. The two fingers should stay behind the seam as long as possible.

Inswing

- Here, the ball is held by the two fingers and the thumb underneath it, with the seam upright and angle towards fine leg.
- The shiny side is on the left side and the fingers may also have a slight gap between them.

Wicket keeping

The wicket keeper plays an important role in cricket. A good wicket keeper can save a number of runs for his team. His function is to stop deliveries, which the batsman is unable to play or passed by batsman.

Fielding

In 21st century, fielding is a key point to win the match. A player requires more hard work, practice and flexibility to become a good fielder.

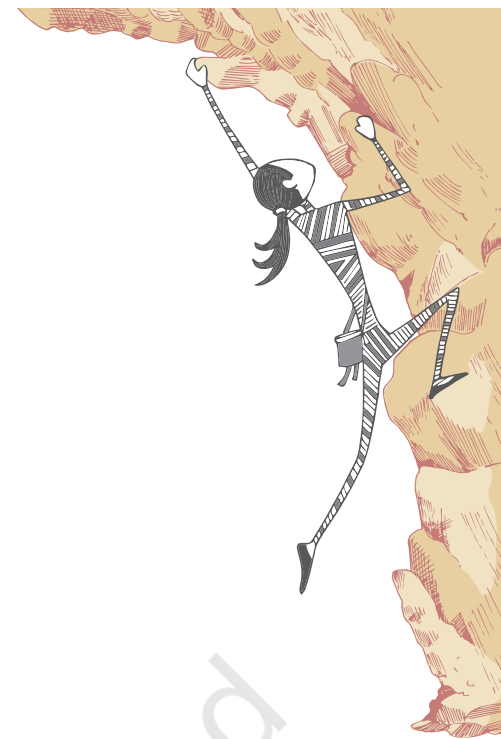

Fig. 6.12: Wicket keeping

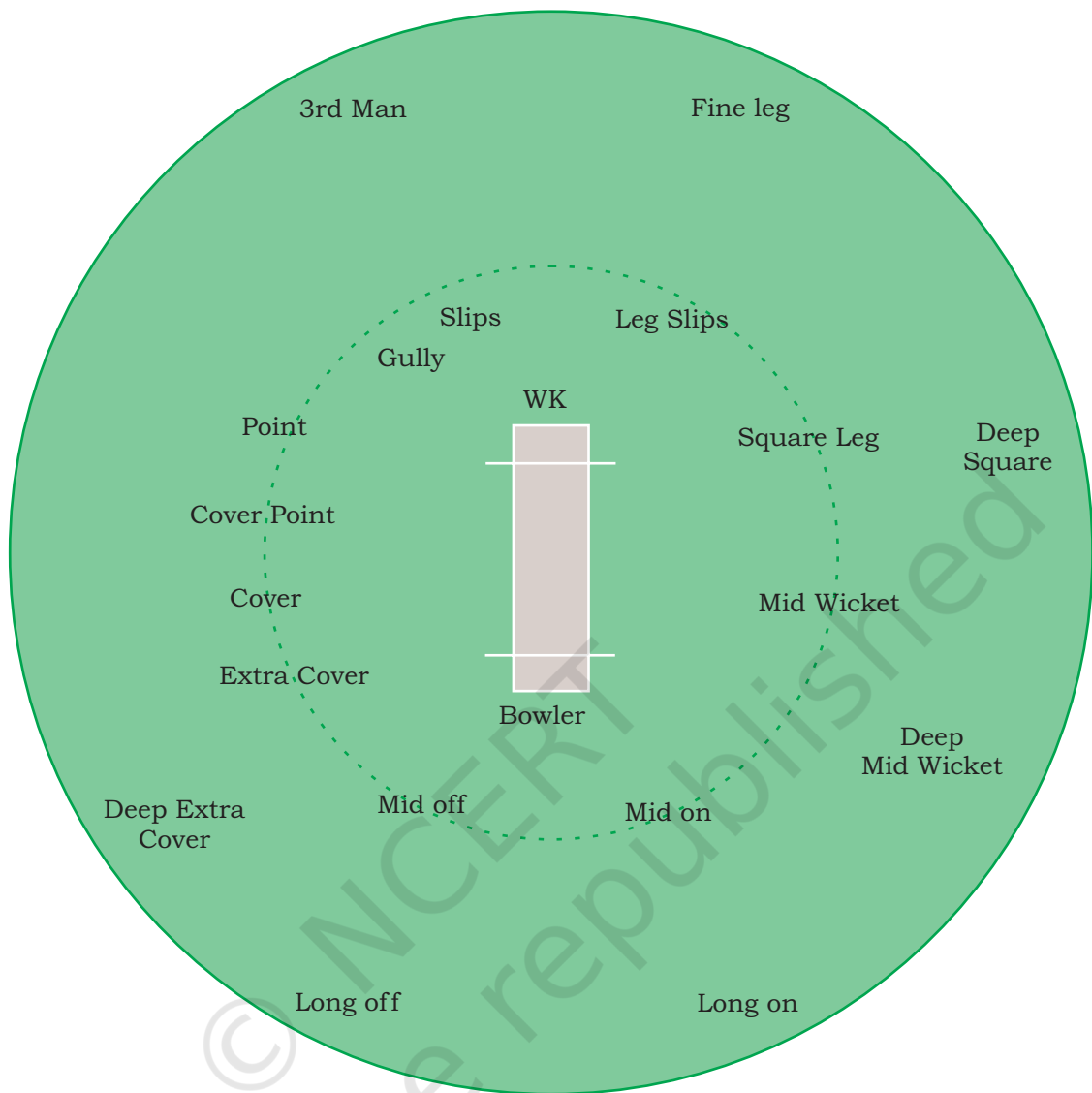
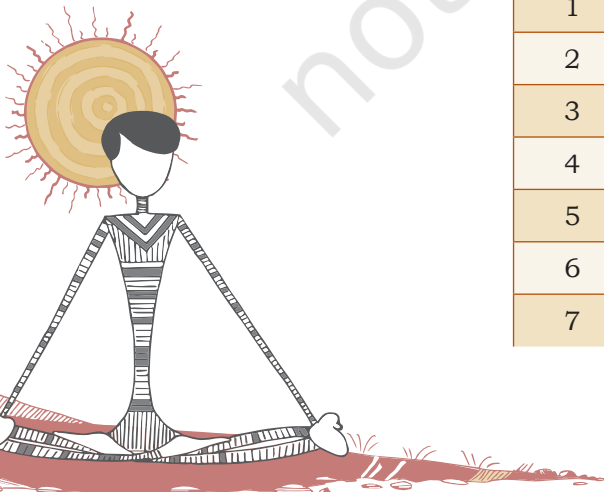

Fig. 6.13: Fielding

Arjuna awardee

S.No.	Name of Player	Year
1	Sachin Tendulkar	1994
2	Sourav Ganguly	1997
3	Rahul Dravid	1998
4	Mithali Raj	2003
5	Anju Jain	2005
6	Anjum Chopra	2006
7	Jhulan Goswami	2010



8	Virat Kohli	2013
9	Harmanpreet Kaur	2017
10	Smriti Mandhana	2018

Bharat Ratna

S.No.	Name of Player	Year
1.	Sachin Tendulkar	2013

FOOTBALL

Football has been a very popular game all over the world since ages. Also commonly known as soccer, it is a game that involves kicking a ball with the foot to score a point. It is played between two teams with a spherical ball on a rectangular field of grass or green artificial turf. There is a goal post at each end of the rectangular field and erected at the middle of base line. Points are scored by moving the ball to an opposing team’s end of the field and putting it between two goal posts. Players are required to move the ball by kicking, dribbling, carrying, and passing. The team that scores more points than the other by the end of the match wins the game.

History

According to FIFA (Federation International de Football Association), the “very earliest form of the game was played in china during the second and third centuries. The game was later developed in England and the rules of football were formulated in India, football began its journey when the British rulers brought it with them and in no time it became popular in the masses. The first recorded game here took place between the ‘Calcutta Club of Civilians’ and the ‘Gentlemen of Barrackpore’ in 1854. The first ever football club in India, the ‘Calcutta Football Club’ was founded in 1872. The first football association, “the Indian Football Association” (IFA) was established in Calcutta in 1893, though there was no Indian on its board till 1930s. It was later, replaced by All India Football Federation (AIFF). The Durand Cup Tournament is the oldest in India and the one of the oldest in the world, was started in Shimla in 1888. The decade of 1951 to 1962 is known as the golden era in the history of Indian football, as the country put up commendable performances in a number of international competitions. India won gold medals in 1951 and 1962 Asian Games, held at New Delhi and Jakarta.

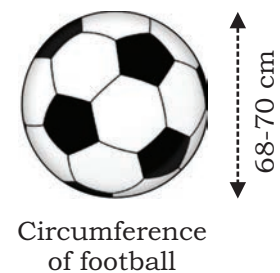
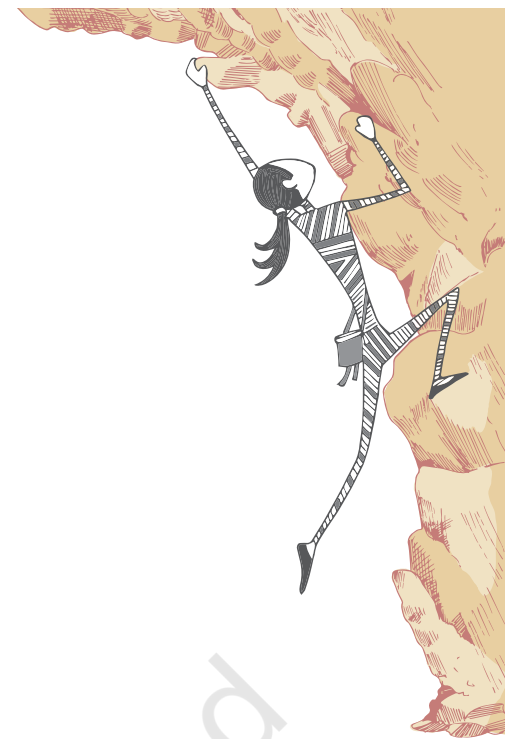

Fig. 6.14: Specifications of football



Fig. 6.15: Children playing football

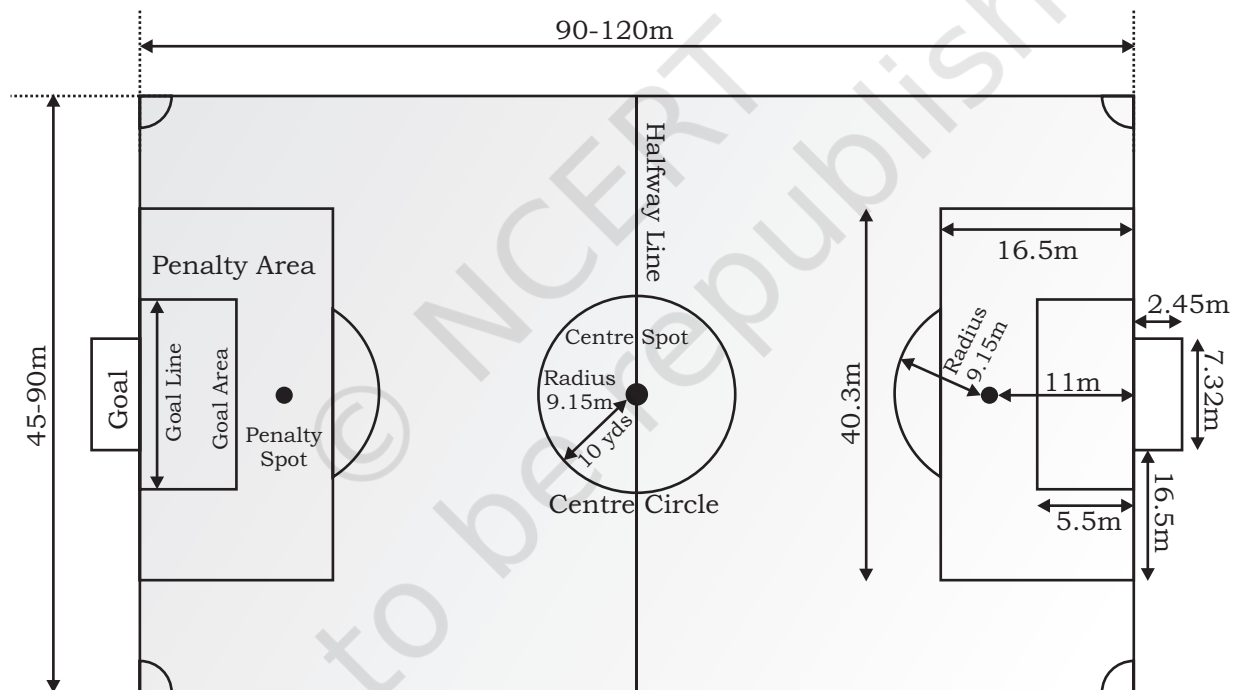
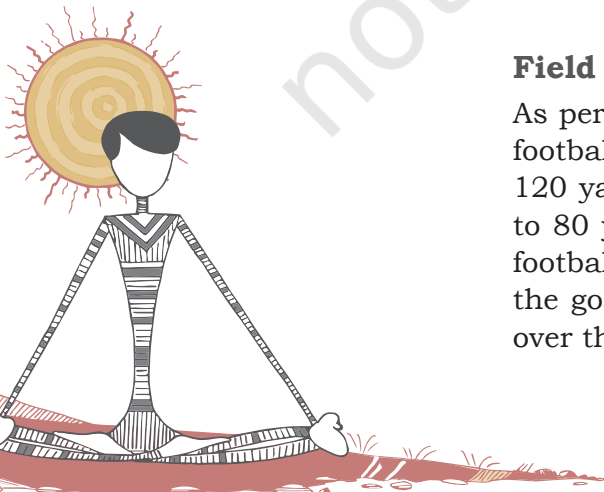

Fig. 6.16: Specifications of football ground

Field measurements

As per international standard, the length of the rectangular football field (pitch) is in the range of 100 to 110 m (110 to 120 yards) and the width is in the range of 65 to 75 m (70 to 80 yards). There are also goal posts at the back of each football zone. One way to score is to kick the football through the goal posts. The ball must go between the uprights and over the crossbar.



Goal post

Distance between the posts is 7.32 meter whereas the height of the goal post is 2.44 meter.

Rules

According to the official rules of football guide, the players need to execute the game in a fair and accepted manner. The football match is played in two halves of 45 minutes each. There are several rules in the game of football regarding the field, players, penalties, offence and defence.

Start and restart of play

A coin toss takes place before the game starts, the winner of the toss will get the choice of choosing the end to attack. At the kick-off, all players from each side must be in their own halves of the field. The kick-off takes place on the centre spot in the centre circle. The player who kicks off cannot touch it again until another player has made contact.

Punishment for offences

If the player persistently offends during a match, the referee can choose to take action. First the Yellow Card as a caution is shown to a player. Any offence after the second one leads to Red card. If they showed a red card to a player it means that player is expelled from the match. A straight red card (no previous caution) can be shown for extreme offences, such as, serious foul play, violent conduct, spitting, deliberately handling the ball to prevent a goal, a professional foul (denying a goal scoring opportunity) and insulting language and/or gestures.

Free kicks

Whenever a free kick is taken, the players on the opposite side must be at least 10 yards away from the ball until it is kicked. If this rule is not adhered to, the kick is retaken. There are two types of free kicks awarded, depending on the nature of the offence: (i) Direct Free Kick — allows the team to take a direct shot at the opponent's goal. (ii) Indirect Free Kick — a direct strike on goal is not permitted. It means a second player has to touch the ball after the kick is taken to score a goal.

Penalty kick

A penalty kick is awarded for offences taking place in the penalty and goal areas. A nominated member of the team is allowed to strike at goal from the penalty spot, with only the goalkeeper to beat. The goalkeeper must remain on his line until the ball has been kicked, and all other players must be outside the penalty area behind the penalty spot. After the

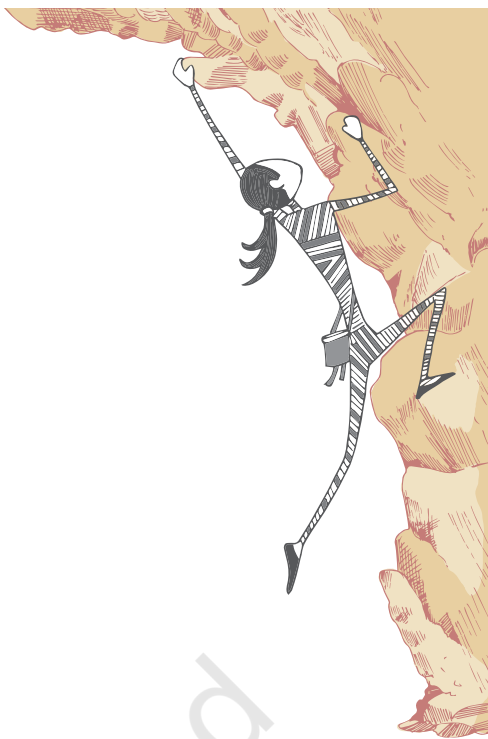

player has taken the kick, that player cannot strike the ball again without another player touching the ball.

Throw-in

A throw-in is awarded when the whole ball crosses the touch line (conceded by the team who last touched the ball). It is delivered on the field of play with both hands and from behind and over the player's head. Otherwise it is deemed to be a foul throw and a throw-in is given to the opposition. It cannot go directly to the goalkeeper's hands (if on the same team). A goal cannot be scored directly from a throw-in.

Corner kick

A corner kick is awarded once the whole ball crosses the goal line of the opposition, after touching one of their players. A kick is taken from the corner of whichever side the ball travelled over the field. Opponents must be 10 yards from the corner arc and the kicker cannot touch the ball a second time without having touched by any other player.

Fundamental skills

Receiving

Receiving a ball on the ground is different than receiving a ball in air. Keep your eye on the ball, select the foot to receive the ball, don't stop the ball, prepare it for new action or move, shot, dribble, pass.

Passing

Passing involves giving the ball to partners. Perfect decision making is required before a perfect pass. Before pass, see the target, approach the ball, and look at the ball holding the head steady. Strike the correct area of the ball with laced ankle, make sure of follow through and transfer of weight forward.

Shooting

Shooting uses the same elements as used in passing, the difference is that the ball is to be passed to the goal keeper to convert the score for the team. Player should look up to see the position of goal keeper, choosing the area to shoot the ball while make a proper contact with the ball with proper follow through.

Trapping

It is a method of gaining control of the ball. Trapping uses the feet, thigh, or chest to bring the ball to the ground.

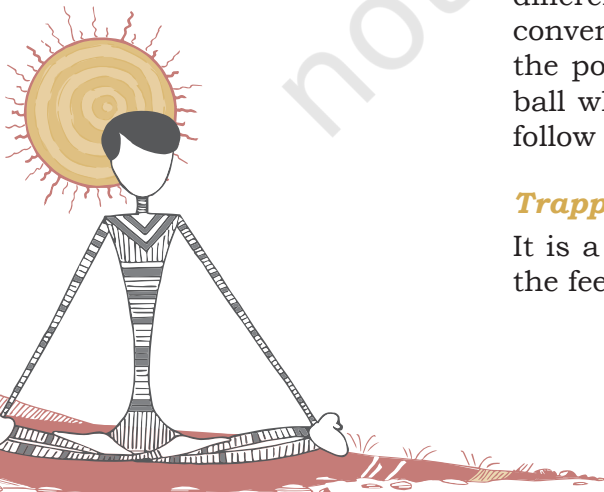

Techniques and lead-up activities

The students already learnt the fundamental techniques of playing football in the previous classes. Now let us discuss a few lead-up activities to develop these techniques.

Ball control

Five versus two in 30m x 20m area. Players make two touches only to retain possession of the ball.

Dribbling

Four quarters of the area are numbered. One player dribbles in one quarter and passes the ball to quarter number 2 and so on. Reaching last quarter, the player without losing the ball gets points. If ball is lost in any quarter, the other teams start anti clockwise and then enter in to the next three quarters.

Passing

Number of players—four. Rectangle measures 5m x 20m or 10m x 30 m, one ball.

Heading

Two versus two, Goal of 8 yards, Centre line 5 yards from each goal.

Shooting

Shooting board is a place along the penalty spot, arranged inside the penalty area.

Tackling

One versus one, 10m x 10m area, time 2 minutes.

Throw-ins

Throw-in is a competition between two players.

Goal keeper

A goal keeper also acts as a defence but is allowed to catch or touch the ball with hands within the penalty box (D-area). A goal keeper is usually the last man standing at the goal to prevent opponents from scoring the goal.

Arjuna awardees

S.No.	Name of Player	Year
1	P.K. Banerjee	1961
2	C.P. Singh	1971

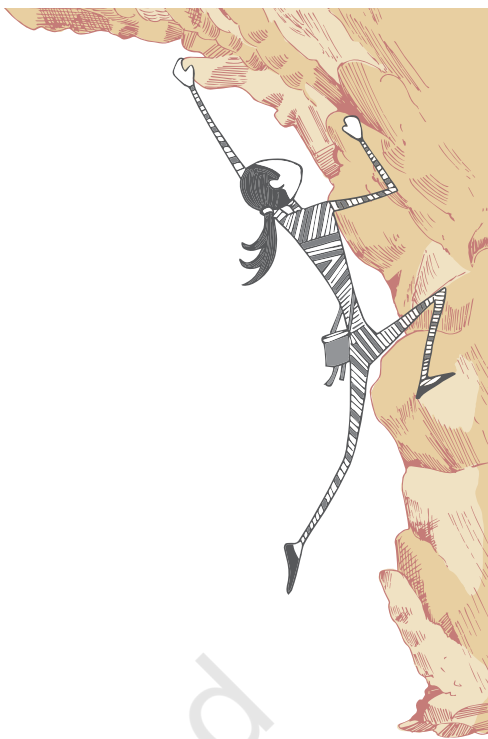

3	Sudhir Karmakar	1981
4	Baichung Bhutia	1998
5	Oinam Bembem Devi	2017

HOCKEY

Introduction

Field Hockey is a team game, in which a team of players attempt to score goals by hitting/Scooping, pushing or flicking a ball into an opposing team's goal using curved sticks. However, the name Field Hockey is used in countries in which the word Hockey is generally reserved for another form of hockey, such as ice hockey or street hockey. The players should learn and practice the basic skills of dribbling, passing, tapping and hitting. They should learn how to attack and score goals and how to work with others to defend and stop goals from being scored. To do this they need to learn how to keep possession by dribbling effectively and moving the ball accurately and quickly between players. As they progress, skills should become more consistent and efficient, and the players should be introduced to set play situations.



Fig. 6.17: Players playing hockey

History

The history of the game of hockey has its roots well laid in the world's early civilisations. One of the oldest known sports, the hockey game is believed to be in existence about 1200 years before the Ancient Games of Olympia. Right from Arabs, Greeks, Romans, and Persians to Ethiopians, every country played with a variation of the game. While some played it just

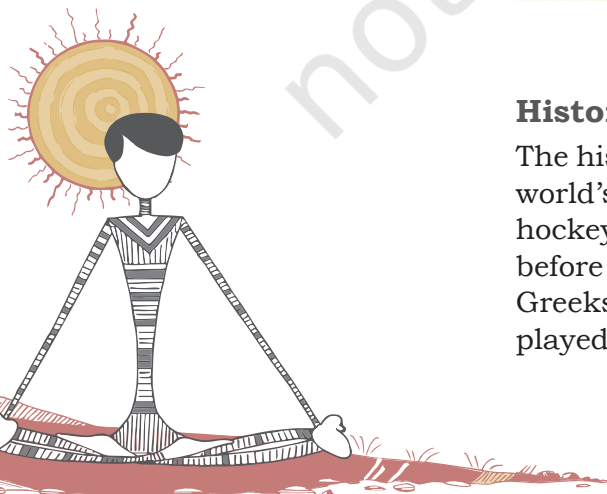

Hockey is played on a 91.40 m × 55 m rectangular field. At each end there is a goal 2.14 m high 1.20 m deep and 3.66 m wide measured from the inner sides of the posts and crossbar, and the goal post is surrounded by an approximately semi-circular area 14.63 m from the goal bounded by a solid line. A spot 0.15m in diameter, called the penalty spot, is marked with its centre 6.40 m from the centre of each goal.

Equipment

Each player carries a stick, normally a little over 3 feet (90 centimeters) long, 2 inches wide and traditionally made of wood but now often made with fiberglass, Kevlar and carbon fiber composites, with a rounded handle flattening out on one side and with a hook at the bottom.

Rules

The rules set by the International Hockey Federation FIH are used worldwide.

General play

Prior to the start of the game, a coin is tossed and the winning captain can choose a starting end or start with the ball. The game time is divided into four quarters of 15 minutes each 15-02-15-10-15-2-15. At the start of each quarter as well as after goals are scored, play is started with a pass from the centre of the field.

Field players may only play the ball with the flat side of the stick. Tackling is permitted as long as the tackler does not make contact with the attacker or his stick before playing the ball (contact after the tackle may also be penalised if the tackle was made from a position where contact was inevitable). Further, the player with the ball may not deliberately use his body or stick to shield the ball from a legitimate tackle.

When the ball passes over the sidelines, it is returned to play from sideline either by individual player by himself or with a push or hit, taken by a member of the team whose players were not the last to touch the ball before crossing the sideline. If it crosses the goal line after last touched by an attacker, a 15 mt hit or pass can be made by any player of the defending team. A 15 mt hit is also awarded for offenses committed by the attacking side within 15 mt of the end, of the pitch they are attacking.

Free hits

Free hits are awarded when offences are committed outside the scoring circles. The ball may be hit or pushed once in any direction by the team offended against. Opponents

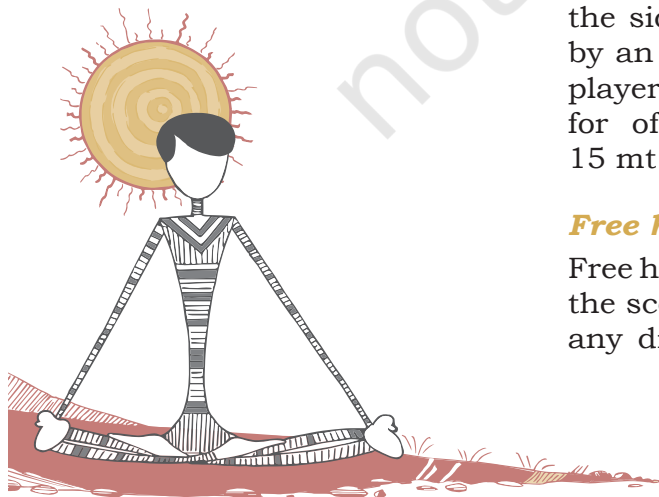

must move 5 mt away from the ball when a free hit is awarded, and for attacking free hits within 5 mt of the circle, all attackers other than the one taking the hit must also be 5 mt away.

Corner

A corner is awarded if the ball goes over the backline after last being touched by a defender. Corners are played by the attacking team and involve a free hit from the 22.90 meter line.

Penalty corner

The penalty corner is set play that is awarded against a defending team when any offence is committed in the defensive circle, and may be awarded when a deliberate offence is committed in the defending 23 m area, or when the defending team deliberately plays the ball over the back line.

Penalty stroke

A penalty stroke is awarded when defenders commit a deliberate foul in the circle which deprives an attacker of possession or the opportunity to play the ball. This penalty is being taken by a single attacker against the goalkeeper, and is taken from a spot 6.4 m from the penalty spot and directly in front of the goal. The goalkeeper must stand with heels on the goal line, and cannot move his feet until the ball is played.

On the umpire's whistle, the striker may push or flick the ball at the goal, which the goalkeeper attempts to save. The player taking the penalty shot may not touch the ball twice. Hitting or dragging or tapping the ball is also forbidden. If the shot is saved, play is restarted with 15 mt hit to the defenders; if a goal is scored, play is restarted from the centre line. Time is stopped for the Penalty stroke.

Dangerous play

If the ball is raised off the ground in a manner that is, in the umpire's opinion, dangerous, the ball is turned over to the other team and they receive a free hit from the point of contact.

Tie breaker (shootout)

In case of a draw match, penalty shootout is conducted. The winners will be decided by 5 penalty shootouts by each team and the team which scores highest number of goals is declared the winner. The shootout will start at 22.90 mt. line in front of the shooter and should be completed within 8 seconds after the umpire's whistle. The goalkeeper will start defence from goal line.

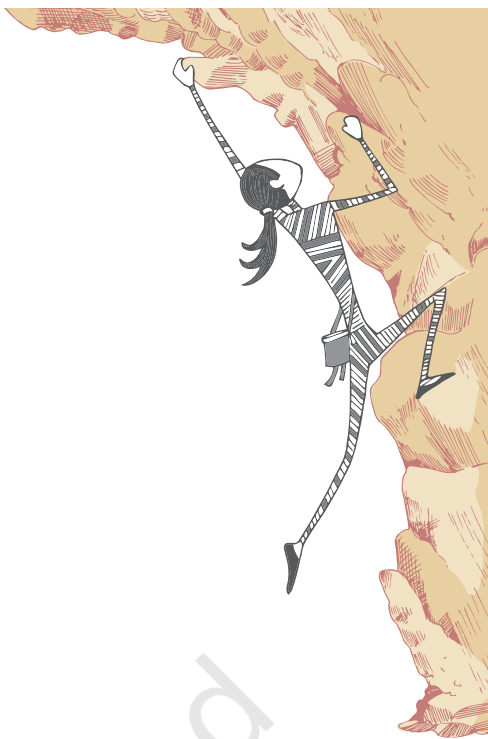

Arjuna awardees

S.No.	Name of Player	Year
1	Prithipal Singh	1961
2	Sunita Puri	1966
3	P. Krishnamurthy	1971
4	Versha Soni	1981
5	Dhanraj Pillai	1995
6	Baljeet Singh Saini	2000
7	Mamta Kharab	2002
8	Ritu Saini and Rani Rampal	2016
9	S.V. Sunil	2017
10	Savita Punia	2018
11	Manpreet Singh	2018

VOLLEYBALL

Volleyball is a net game that involves two teams of 12 players (six playing and six substitutes). Each team works together to hit an inflated ball over a high net. Each team tries to score points by grounding the ball on the other team's court. Volleyball is a rebound game where one cannot hold or catch the ball; every contact must be a rebound action. It is essential for the player to be in the right place at the right time if the game is to be played in a controlled manner. Therefore, good anticipation and movement skills should be taught to players. At competency level, students should learn and practice the basic skills of sending and receiving the ball over a high net. They should play simple 3 touch volleyball games working as a team to keep the ball in play and ground it on the opponent's side of the court.

History

Originally named Mintonette, it was created as a gentle indoor sport for older players to be able to exert a bit of athletic effort by keeping the ball in the air. The idea of using a net was borrowed from tennis. It was raised to a height above the average man's height. During a demonstration game, someone remarked that the players seemed to be volleying the ball back and forth over the net, and perhaps "volleyball" would be a more descriptive name for the sport. The game of Volleyball was invented by William G. Morgan in the year 1895 in Holyoke, Massachusetts by YMCA (USA). It was invented as a recreational game. This game was brought to India more than 85 years ago when some physical education

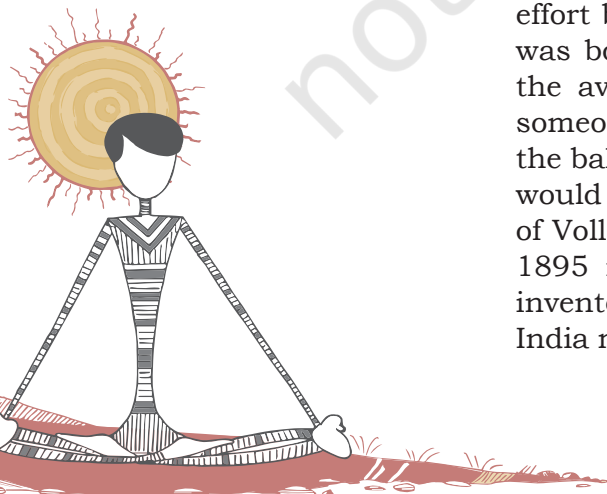

teachers had been abroad and were trained in different games including Volleyball. YMCA College of Physical Education, Madras, took this game seriously and students trained there have taken the game to other parts of the country.

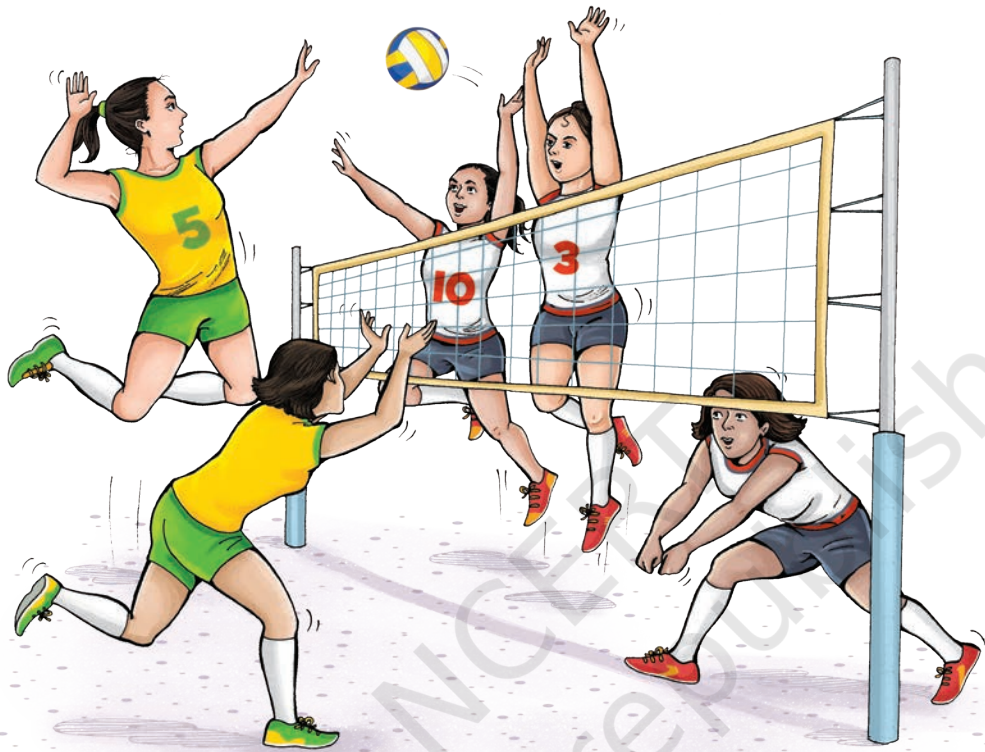

Fig. 6.19: Players playing volleyball

Measurements

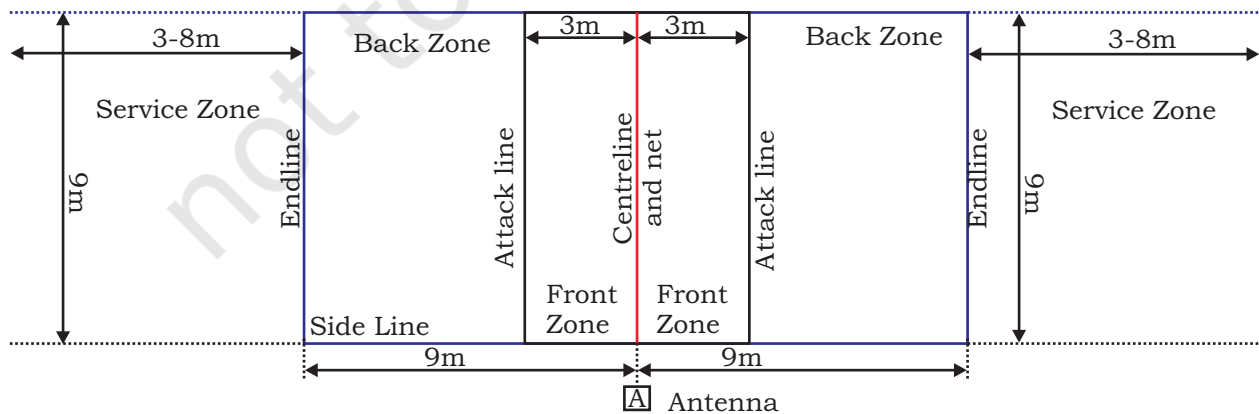

Fig. 6.20: Specifications of volleyball court

NETR Posts

The net is 2.43 mt high for men and 2.24 mt high for women. It is doubled vertically over the center line. It is 1 m wide and 9.5-10 m long end is 10 cm more bleak mesh. The antenna is a flexible rod 1.8 m long and 10 mm. in diameter centered fixed an side line near pole. The top on antenna extends 80 cm above the net. The 2.55 m high posts are placed 0.5 m – 1.0 m out side the side line.

Rules

Volleyball is a fast game played by two teams of 6 players each. It can be played indoors or outdoors. A player on one of the teams begins a 'rally' by serving the ball from behind the back line of the court, over the net, and into the receiving team's court. The receiving team must not let the ball be grounded within their court. The rally continues, with each team allowed up to three consecutive touches, until either a team grounds the ball on the opponent's court and wins the rally or a team commits a fault and loses the rally. The team that wins the rally is awarded a point, and serves the ball to start the next rally. The ball is usually played with the hands or arms, but players can legally strike or push the ball with any part of the body.

Common faults include —

- catching and throwing the ball;
- two consecutive contacts with the ball made by the same player;
- four consecutive contacts with the ball made by the same team;
- touching the net during play;
- crossing the centre line; and
- violation of rotation.

Fundamental skills and lead-up activities

104

Smash

- Run and approach as per the height, distance and speed of the ball.
- Swing the arm back behind the body. Bend slightly and jump off both feet. Swing the arm back behind the body.
- Hit the ball between the head and the hitting shoulder, in front of the body and with an outstretched arm.
- Land in a balanced position on both feet and shift weight from toe to heel. Flex knees to avoid injury.



- Setting up the ball, sending and receiving practices requiring students to:
 - Overhead pass, underhand pass the ball.
 - Keep the ball in the air. Play in a circle or small group: how long can you keep the ball in the air?
- Striking the ball against the wall
- A player strikes the ball on the surface keeping in view the force and direction in a manner that the ball hit the wall and deflects within the reach of Player B and the rally goes on.



Fig. 6.21: The smash

Block

- Block is the first line of defence against the smash. It may be performed by one, two or three front-row players who jump at the net.
- Stand in a balanced position about half a meter from the net, feet shoulder width apart.
- Watch the opposition developing their attack and move quickly to where it is anticipated.
- Use side steps or cross steps to move along the net.
- Coordinate with the timings of the jump of attacker and raise hands above the net to block the smash.
- Move to receive passes: from a ready position, players should move right or left to receive a pass and return it.
- Play simple games that combine serving, overhead pass and underhand passes.
- Mark a chalk line on the wall. Practice the blocking action. Jump using vigorous knee extension and controlled arm movement. Both hands must touch simultaneously above the mark. Practice blocking at the net with one, two or three players.

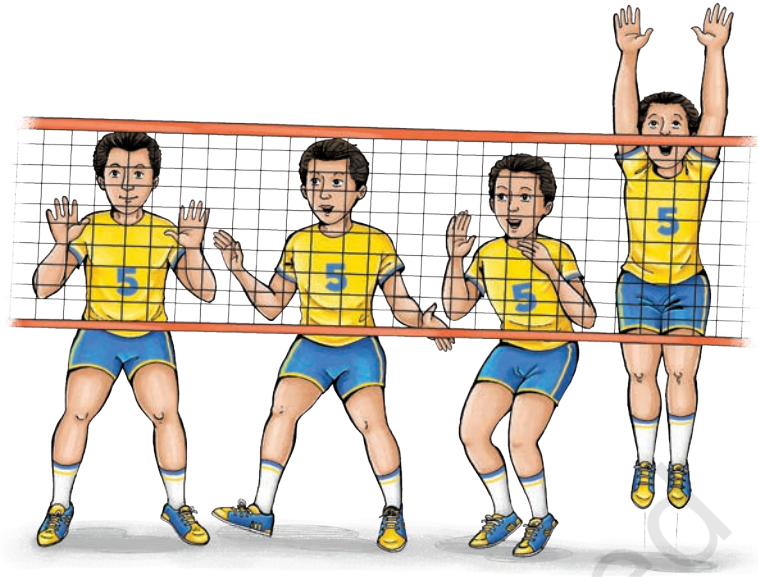

Fig. 6.22: The block

Arjuna awardees

S.No.	Name of Player	Year
1	Nripjit Singh	1962
2	G.M. Reddy	1973
3	K.Udaya Kumar	1991
4	Amir Singh	2001
5	Tom Joseph	2014



ASSESSMENT

BASKETBALL

I. Answer the following Questions

1. List any five important rules of the basketball game.
2. List any five penalties of basketball game.
3. How does playing basketball help us in the improvement of our health?
4. Which is the motor skill you enjoyed the most and why?
5. Explain any one fundamental skill of basketball game.
6. How can you improve your performance in the game of basketball?

II. Fill in the Blanks

1. Measurement of a basketball court is _____ .
2. Height of the lower edge of the board from floor is _____ .
3. Diameter of the ring is _____ .
4. Duration of one quarter is _____ .
5. Duration of team time out is _____ .

III. State whether True or False

1. Five players are required to start a game.
2. Basketball game was invented in 1981.
3. Player is to be substituted within 20 seconds.
4. Player can leave the court at any time.
5. After five fouls player has to leave the court.

IV. Assess your Performance by the following Activities

1. Dribbling Test: Zig Zag dribbling for 30 seconds
2. Passing Test: Passing on the wall for 30 seconds from 5 mt. distance
3. Shooting Test: Shooting for 30 seconds from under the basket position

CRICKET

I. Answer the following Questions

1. List the basic rules of the game of cricket.
2. What has been the impact of Twenty20 form of cricket on Test Matches?

II. Fill in the Blanks

1. Cricket became an international game with the formation of the _____ in 1909.
2. The name of Imperial Cricket Conference was changed to _____ to enable countries outside the Common Wealth to become its members.
3. The International Cricket Council (ICC) staged the first limited over Cricket World Cup in _____.
4. The lines that delineate the width of the court are called the _____.
5. The Indian Cricket Control Board came into being towards the end of _____.
6. The National Cricket Championship known as _____ Trophy, named after Prince Ranjit Singhji of Nawanagar.

FOOTBALL

I. Answer the following Questions

1. What is the stipulated size of the field for playing football according to the international standard?
2. How many players constitute a football team and what are their positions?
3. What are the basic equipment required for football teams?
4. What role does the Referee play? Who are the other officials in the football match?
5. What is the official duration of a football match? How far can it be extended and why?
6. On how many occasions is the kick-off used during a football match?
7. What are the penalties that the Referee can award against offences during the match?
8. What are the rules regarding free kick, penalty kick, throw-in and corner kick?
9. What are the norms of fair play in football for footballers and spectators?

II. Fill in the Blanks

1. The first ever football club in India, the _____ was founded in 1872.
2. The first football association, known as "Indian Football Association" (IFA) which was established in 1893 was replaced by _____.
3. The decade of 1951 to 1962 is known as the _____ era in the history of Indian football.



4. India became the first Asian nation to reach the Olympic football semifinals in the _____ Olympics.
5. The Asian Football Confederation (AFC) was formed in the Second Asian Games held in Manila in _____ .

HOCKEY

I. Answer the following Questions

1. Write a brief note on the history of Hockey in India.
2. What are the rules of the game in respect of (i) field, (ii) players, (iii) equipment, (iv) free hits, (v) long corner, (vi) short corner, and (vii) penalty stroke?

II. Fill in the Blanks

- (a) If the ball is raised off the ground in a manner that is, in the umpire's opinion, dangerous, the ball is turned over to the _____ and they receive a _____ from the point of contact.
- (b) Hockey uses a three-tier card system of warnings and suspensions and these are known as (i) _____ card, (ii) _____ card, and (iii) _____ card.
- (c) The procedure laid down in FIH tournament regulations for tie breaker mandates _____ minutes each way of "golden goal" extra time (i.e. the game ends as soon as one team scores). If scores are still levelled, the game will be decided with _____.

VOLLEYBALL

I. Answer the following Questions

1. What are the advantages of playing volleyball?
2. Which motor skill you enjoyed the most and why?
3. Explain any one technique of volleyball.
4. How can you improve your performance in the game of volleyball?

II. Fill in the blanks

1. The first game of volleyball was played in _____
2. Volleyball is a fast game played by two teams of _____ players each.
3. When the rally continues, each team is allowed upto _____ consecutive touches.

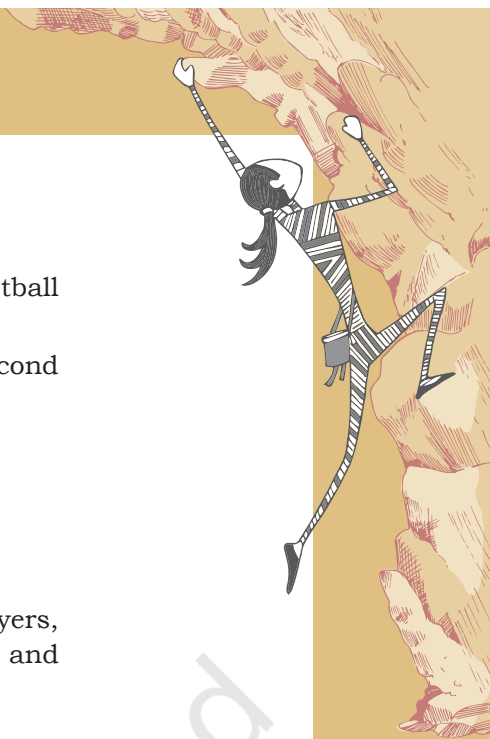

III. State whether True or False

1. It is considered as a fault if six players are playing the game.
2. A player catches and throws the ball.
3. Three consecutive contacts with the ball made by the same team are allowed.
4. Two consecutive contacts with the ball made by the same player are allowed.
5. The player touches the net during play.

© NCERT
not to be republished



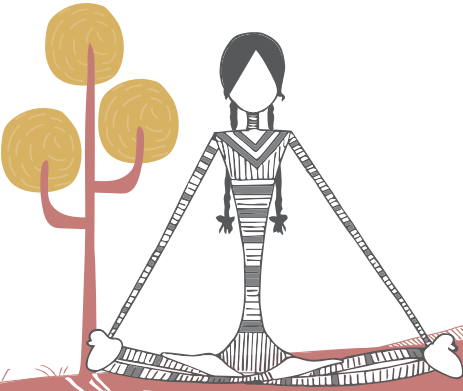

TEAM GAMES AND SPORTS II



In the previous chapter, we have discussed team games like Football, Hockey, Basketball, Cricket and Volleyball. This chapter includes Kabaddi, Kho-Kho and Combative sports like Judo and Wrestling.

KABADDI

Kabaddi is an indigenous game which is popular in India. It is a simple and inexpensive game and does not require a big playing area or any equipment. This game is popular in the villages and small towns in India. It is played throughout Asia with minor modifications. Kabaddi is quite new to the other parts of the world. It was known by various names in different parts of India. For example, Chedugudu or Gudugudu in Southern parts of India, Ha-du-du (Men), Chu-kit-kit (Women) in Eastern India, Hu-tu-tu in Maharashtra in western India and Kabaddi in Northern India. It is a game of attack and defense. The two teams occupy opposite halves of a field and take turn in sending a 'Raider' into the other half. In order to win points, members of the opposite team are tagged and the raider tries to return to half, holding the breath and chanting, "Kabaddi, Kabaddi, Kabaddi".



1077CH07



Fig. 7.1: Children playing kabaddi

Do You Know?

- Pro Kabaddi League was established in 2014.
- Women Kabaddi Challenge was first played in 2016.
- 2019 Kabaddi World Cup was held in April 2019 at Malaysia. It is the largest World Cup in the history of kabaddi consisting of 32 men's team and 24 female's teams.

History

According to some historians Kabaddi might have developed during prehistoric times when human beings were forced to defend themselves from sudden attacks from ferocious beasts. There is also another school of thought, in India, which believes that this game is a version of Chakravyuha, used in Mahabharata. The game was demonstrated for the first time at the international level during 1936 in Berlin Olympics by *Hanuman Vyayam Pracharak Mandal*, Amravati, Maharashtra. The game was introduced in the Indian Olympic Games at Calcutta in 1938.

In 1950, the All India Kabaddi Federation came into existence and compiled standard rules. The Amateur Kabaddi Federation of India (AKFI) was founded in 1973. After formation of the AKFI, the first men's nationals were held in Madras (Chennai), while the women's were held in Calcutta (Kolkata) in 1955. The Asian Kabaddi Federation (AKF) was founded in 1978. AKF is affiliated to Olympic Council of Asia. The parent body designated to regulate the game at the international level is International Kabaddi Federation (IKF). The Kabaddi World Cup was first played in 2004, then in 2007 and 2010. So far India is the unbeaten champion in Kabaddi World Cup. Iran is the next most successful nation being runners-up twice. Pakistan was the runners-up in 2010.

Rules**Kabaddi field measurements**

S. No	Field measurements	Men	Women
1	Side lines (AB, CD, EF & GH)	13 meter	12 meter
2	End Line (AD, BC)	10 meter	8 meter
3	Lobby (AE, BF, DG, CH)	1 meter	1 meter
4	Baulk Line (from Mid line) (LN, KM, LR, KQ)	3.75 meter	3 meter
5	Baulk Line (RQ, MN)	8 meter	6 meter
6	Mid-line (IJ)	10 meter	8 meter
7	Bonus Line (TS, PO) from Baulk Line (RT, QS, MO, NP)	1 meter	1 meter
8	Bonus Line (MN, ST)	8 meter	6 meter
9	Sitting Block (2 meters away from End lines)	8×1 meter	6×1 meter
10	Court (each half of the playfield divided by the mid line)	6.5×8 meter	6×6 meter
11	Space surrounding the play field	4 meter	4 meter
12	Duration of the match	20-5-20 Minutes	15-5-15 Minutes

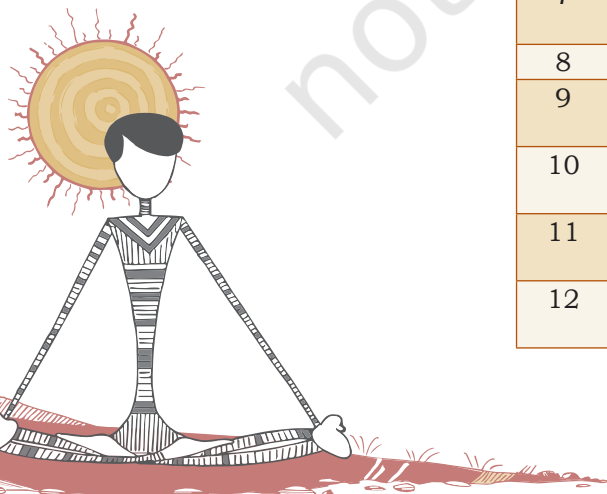

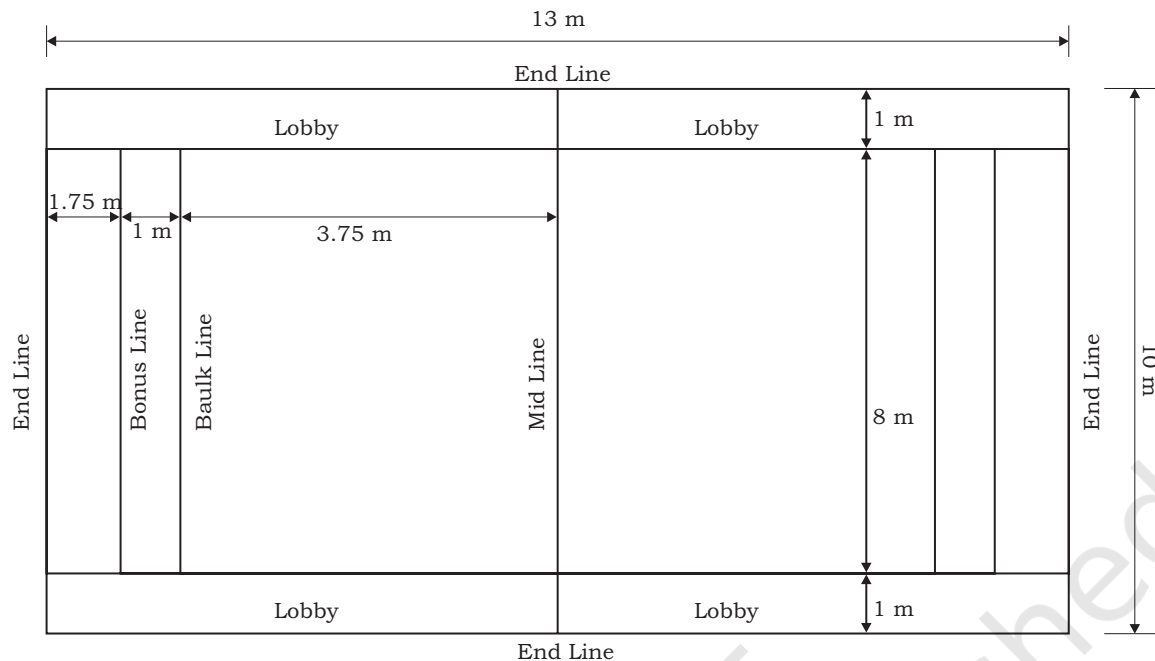

Fig. 7.2: Specifications of Kabaddi court

Court

The Kabaddi court measures 13×10 meters for men and 12×8 meters for women with a line dividing it into identical halves denoting actual playing area of the two teams. Traditionally the game is played outdoors and the entire court is dug at least 1 foot deep. The mud is removed and filled with sand from the river or beach. This ensures that the player is not seriously injured if he falls or is dragged by opponents. However, now synthetic Kabaddi fields are used for comfort and to reduce injuries. Tournaments like the Indian Kabaddi league have emerged as crowd pullers in urban areas.

Team

Each team shall consist of minimum 10 and maximum 12 players. Seven players shall take the ground at a time and the remaining players are the substitutes.

Duration of the match

The duration of the match is divided into two halves of 20 minutes each. In case of men and junior boys there is a 5 minutes interval and in case of women, junior girls, sub-junior boys and girls two halves of 15 minutes with 5 minutes interval. The teams shall change court after interval. The number of players for each team at the start of the second half shall remain the same as it was at the end of first half. The last raid of each half of the match shall be allowed to be completed even after completion of the scheduled time as mentioned above.

System of scoring

One point score will be given to each team for every opponent who is deemed out. And if your team, makes all the players of your opponent team out, your team is entitled to get 2 points as a bonus. This is known as Lona.

Time out

- Each team shall be allowed to take two time outs of 30 seconds in each half. Such time out shall be called for by the Captain, Coach or any playing member of the team with the permission of the Referee. The time out duration shall be added to match time.
- During time out, the team shall not leave the ground. Any violation of this will result in the award of a technical point to the opponent team.
- Official time out shall be called for by the Referee or Umpire in the event of any injury to the player, interruption by outsiders, re-marking of the ground or any such unforeseen circumstances. Such time out will be added to the match time.

Substitution

- Five reserve players can be substituted with the permission of the referee during time out or interval.
- Substituted players can be re-substituted.
- If any player is suspended or disqualified from the match, no substitution is allowed for that particular player. The team will play with less number of players.
- No substitution is allowed during the official time out.
- Substitution is not allowed for players who are deemed out.

Bonus point

- One point shall be awarded to the raider when they cross the bonus line. If the raider after crossing the bonus line, (is caught) the opponent team will also be awarded one point.
- The bonus line will be applicable when there are a minimum of 6 players in the court; the bonus point shall be awarded by the referee after completion of such a raid by showing thumb upward towards the side which score.
- If the raider while crossing the bonus line is caught, then a point will be awarded to the defending team. No bonus point shall be given to the attacking team.
- If the raider, after crossing the bonus line, puts out one or more antis, they will get the number of points

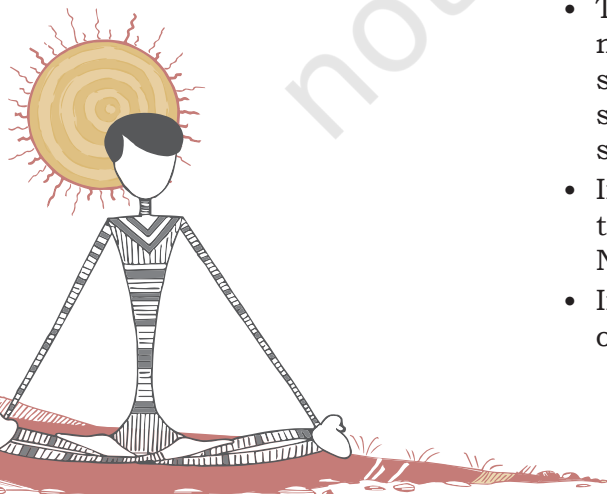

scored in addition to the bonus point for crossing the bonus line.

- The raider has to cross the bonus line to score the bonus point before touching the antis or before he is caught by the antis. The raider will not be awarded bonus points if they cross the bonus line after a touch or struggle.
- There shall be no revival for bonus points.
- If player is suspended temporarily or disqualified from the match, then the team will play with less number of players. Such players shall be counted while awarding bonus point.

Result

The team which scores the highest number of points at the end of the match shall be declared the winner.

Precautions

- Players should have clipped nails and no ornaments of any sort shall be allowed.
- All players must have distinct numbers on their T-shirts of at least 4 inches thickness in front and 6 inches thickness at the back. Dress code is followed compulsorily by both the teams during competitions.
- Application of oils or any other soft substances to the body shall not be allowed.
- Shoes are compulsory in case the match is played on the mat surface.

Fundamental skills

Skills

The skills used by the raider in kabaddi are called offensive skills. The skills used by the antis are called defensive skills. During a raid, the raider has to make maximum use of his limbs to come in contact or touch the opponents in order to score points. This is accomplished through leg touches, such as, toe touch, foot touch, squat leg, thrust, kicks, etc., with lower limbs and through hand touches with upper limbs.

Offensive skills

- a) Touch: Touch is a fundamental and the easiest skill, which every raider applies in one or the other forms. There are different kinds of touches such as —
 - (i) Hand touch: (a) running hand touch (b) stooping hand touch (c) turning hand-touch (d) hopping hand touch (e) fake and touch
 - (ii) Toe touch: This offensive skill is used by almost every raider. A raider can execute this





skill even from a considerable distance from the anties. During the course of a raid, the raider will move in different angles, according to the positions and moves of the opponents. At the same time, in order to apply this skill, the raider requires to extend his leg towards the opponent suddenly.

- (iii) Foot touch: The modern toe touch is a moderate form of foot-touch. The major difference between these two skills is that in foot-touch, the raider tries to touch the opponents with complete foot whereas in toe touch, toe is used to touch the opponents. This skill helps the raider to cover more area in the opponent's court and has an advantage over toe touch.
- b) Mule kick: It is very useful in critical situations. Mule kick is a thrust or blow in the air, by the raider, with leg, to touch an anti. There are various types of kicks, such as —
 - i. Back kick: Kicking the anti who comes behind the raider during the course of raid is known as back kick. The different forms of back kick are: (i) running back kick (ii) standing back kick (iii) fake and kick (iv) taking a turn and back kick.
 - ii. Side kick: Raiders who raid from second to second and attack the central zone will find this skill the most suitable. The method and principle of kick are the same as in the case of back kick. The only difference between the two is that the area to be covered is sideward.
 - iii. Curve kick is also called a mule kick as the leg lifted to kick at the anties takes a curve from back to the side. This type of kick will enable the raider to cover more area with the attacking leg. At the same time it enables the raider to change his direction.

Defensive skills

- a) Ankle hold: This is a counter skill used by defensive players against leg thrusts and foot touches during an attack or raid. A team, which has mastery over ankle hold, can plan different strategies and tactics in various situations, such as, (a) lifting up (b) pulling back (c) changing direction of the raider.

- b) Thigh hold: This skill is a good defensive skill. Every team uses this technique as a planned and surprise tactic. For example: (a) Taking one step forward and hold — Taking one step forward means holding the raider's thigh on wrong step or rear leg (b) thigh hold from behind.
- c) Waist hold or trunk hold: Waist hold is a skill used by a defender to catch the raider from behind.
- d) Wrist hold: Wrist hold is also a defensive skill and used occasionally only when a situation presents itself. This hold is rarely used now a days.
- e) Blocking: It is a defensive skill used by covers and corners. Blocking is an act of creating a wall of obstruction in the path of the raider to prevent the movement. The aim of blocking is not just to obstruct the path, but also to catch the raider.

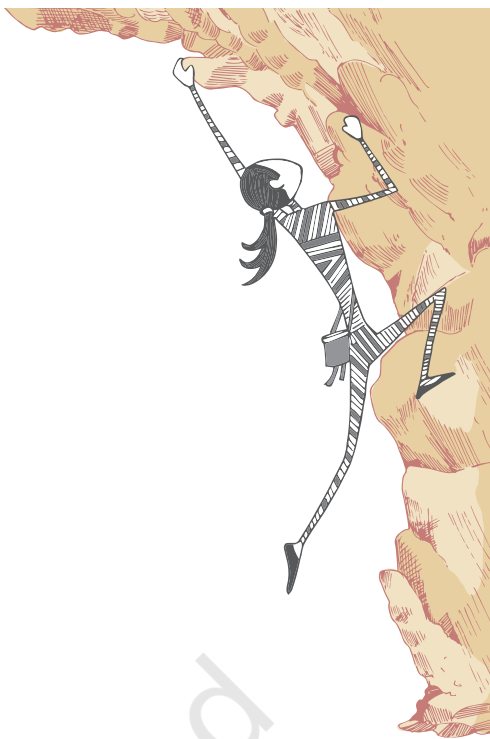

Tactics

Tactics means exploiting a given situation to one's advantage. This is also done to create a situation to suit one's purpose. The raider may increase or decrease the tempo of the game depending on the situation. In order to do this the player may adopt a passive raid or an aggressive raid by creating a situation for a struggle. Sometimes the raider may pass time in the last few minutes of the game, especially when the team is leading and the opponents are playing an aggressive game. Keeping in view the game situation, different tactics adopted by the raider.

Retreat

Unless the raider returns to home court safely after the raid, the raid cannot be treated as successful. This is called a retreat. The raider has to pre-plan the path of retreat before starting the raid. While retreating to home court, the raider should keep the following points in view —

- The raider does not give room for pursuit.
- The raider regains their defensive position quickly before the opponent team's raider begins the raid.
- While returning to home court, the raider must pass only through the midline.

Raid

Raid is the offence part of the game. The main feature of the game is raiding on the opponent's court, alternatively by both the team players. The defence is done with teamwork while only one player makes an attack.

Cant

'Cant' is holding of breath by the raider during the attack and chanting the word kabaddi, kabaddi, respectively, in one single expiration.

KHO-KHO

Kho-Kho is one of the most popular traditional team sport in India. It is the simplest form of chasing and touching a person. It is an inexpensive and enjoyable sport that demands physical fitness and a set of skills. Dodging, feigning and bursts of controlled speed make this game quite thrilling. To catch by pursuit is to chase, rather than just run — is the main skill of Kho-Kho. This game is played in two innings by two teams on a rectangular court. One team becomes the chasers and the other the runners. In the game, the chaser pursues the runners and touches them and puts them out. Each team has to chase and defend for 9 minutes twice in a match.

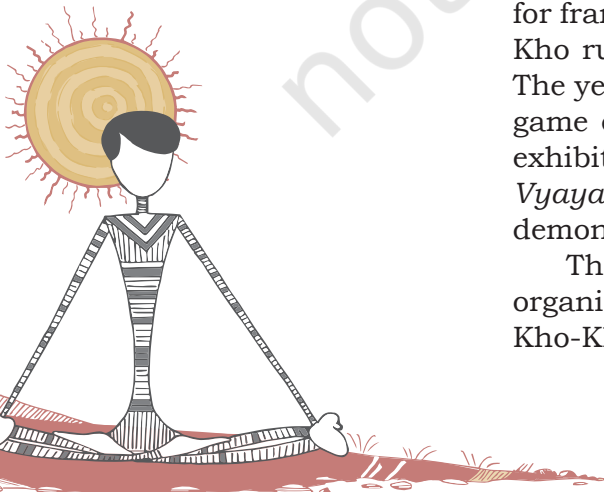

Fig. 7.3: Player playing kho-kho

History

In the ancient era, a version of the Kho-Kho game was played on 'raths' or chariots in Maharashtra, and this was known as RATHERA. The Kho-Kho rules were first framed in the early 1900's. A committee was formed at Puna Gymkhana in 1914 for framing the Kho-Kho rules and the first ever book of Kho-Kho rules was published from Baroda Gymkhana in 1924. The year 1936 was the year of the golden opportunity for the game of Kho-Kho when Berlin Olympic Games featured an exhibition of Kho-Kho in the main stadium. The *Hanuman Vyayam Prasarak Mandal* of Amravati was the proud demonstrators in that exhibition.

The first ever All India Kho-Kho Championships were organised at Vijaywada in 1959-60 under the auspices of Kho-Kho Federation of India. In 1969-70 the junior age group



competitions were organised in Hyderabad. Competitions for women's junior-group, girls under 16, were held in 1974 at Dewas when two more sub-junior groups for boys under 14 and for Girls under 12 also commenced. In the tournament best sub-junior boys were awarded Bharat Award and best sub-junior girls Veer Bala Award. In 1987, a demonstration was held in South Asian Games and Asian Kho-Kho Federation came into existence with three countries as its members. The Indian Olympic Association had included Kho-Kho as a discipline in the South Asian Games which was held at New Delhi in 2013.

Playfield

A Kho-Kho playground (or pitch) is rectangular. It is 27 meters in length and 16 meters in width. There are two rectangles at the end.

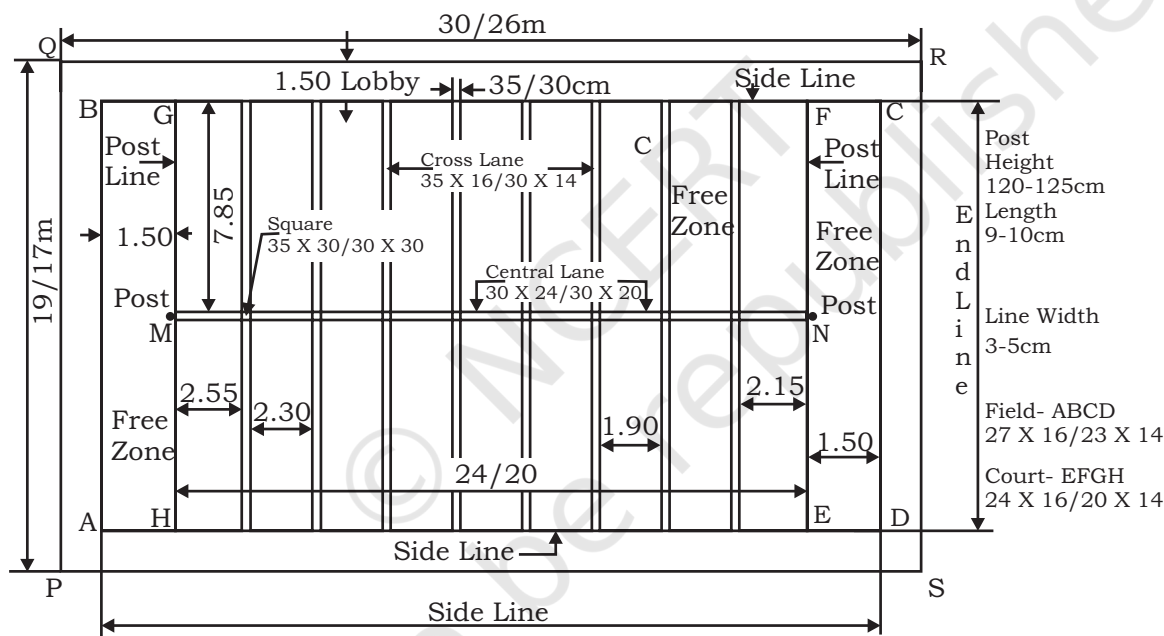
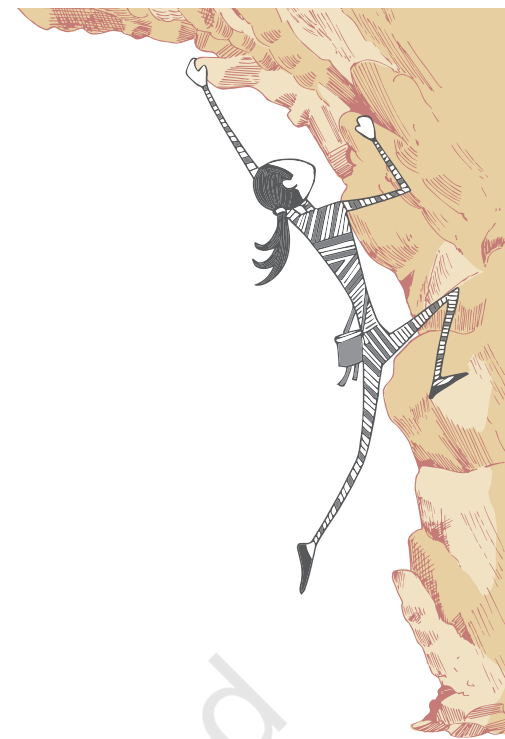

Fig. 7.4: Specifications of kho-kho ground

One side of the rectangle is 16 meters and the other side is 1.50 meters. In the middle of these two rectangles, there are two wooden poles. The central lane is 24 m long and covers an area of 35 cm x 30 cm. There are eight cross lanes which lie across the small squares from pole to pole and right angles to the central lane is divided equally into two parts of 7.85 m each by the central lane. At the end of the central lane, two poles are fixed. These are 120 to 125 cm above the ground and their circumference is not less than 30 cm and not more than 40 cm. These poles are made of wood which are smooth all over. The poles are fixed firmly in the free zone tangent to the pole-line.



Rules

- The team consists of 12 players, but only 9 players take the field for a contest.
- A match consists of two innings. An inning consists of chasing and running turns of 9 minutes each.
- Then, one team sits in the middle of the court, in a row, with adjacent members facing opposite directions.
- The chasers can only run in one direction and cannot cut across the sitters unlike the dodgers who can run randomly and in between the sitters.
- They have to run round the entire row to reach the other side.
- The other option is to pass the chasing job to another sitter whose back is facing the chaser as the chaser is running.
- In this option, the chaser touches the sitter he wants, usually nearest to the target and shouts “kho” to signify the change of guard.
- The objective is to tag all the opponents in the shortest time possible.
- The team that takes the shortest time to tag maximum number of opponents in the field wins.

Fundamental skills

Offensive skills

1. Giving kho to side: To chase a defender
 - (i) Two steps kho (proximity and distal step)
 - (ii) Advance kho: Running ahead of defender and dropping kho.
 - (iii) Deceptive kho: To deceive defender by different body movements.
2. Pole turning: To turn the pole in continuation of attack
 - (i) Pole turning from 8th square (from sitting position).
 - (ii) 4 up turn: Turning pole by taking four steps.
 - (iii) 5 up turn: Turning pole by taking five steps.
 - (iv) Running pole turning: Pole turning without giving Kho.
3. Covering on cross lane: To cover the defender on cross lane.
 - (i) Quadruped
 - (ii) Biped
 - (iii) Rush Through
 - (iv) Combination

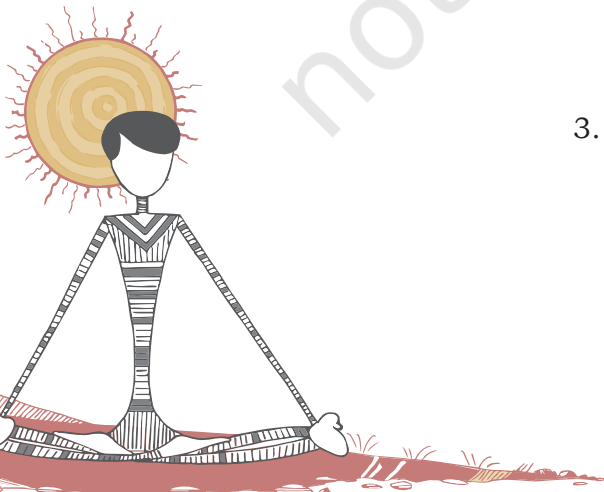

4. Pole dive: Taking support of pole and touching the defender.
 - (i) Running pole dive
 - (ii) Pole dive from 8th square (Sitting)
 - (iii) Judgment kho and pole dive
 - (iv) Running flat dive
 - (v) Steady dive
 - (vi) Side dive
5. Tapping
 - (i) Shoulder tap: Touching the shoulder of defender.
 - (ii) Heel tap: Touching the heel of defender.

Defensive skills

1. Chain game: Defender takes entry behind the sitting chaser and runs in a zig-zag path by making the attacker give kho from behind.
 - (i) Six Single up
 - (ii) Two five six up
 - (iii) Two three six up
 - (iv) Three four five six up
 - (v) One four five six up
 - (vi) One four seven one
2. Ring game: Defender runs in the shape of a ring (oval shape) by making use of four squares. In front ring defender faces the attacker. In back ring defender shows his back and plays ring game.
 - (i) Short ring - Defender stands close to the centre lane.
 - (ii) Medium ring - Defender stands almost half the way from the centre lane.
 - (iii) Long ring - Defender stands away from the central lane but.
3. Combination of chain and ring game
4. Dodging: To deceive the attacker, different body dodge is used. Shoulder dodge, Foot dodge, combining both skills of defence, 3-ring defence.
5. Avoiding the pole: The defender stands between last square and pole without reaching pole.

Palti

By showing his back, the defender deceives the attacker and turns in the opposite direction to the direction in which he was running.

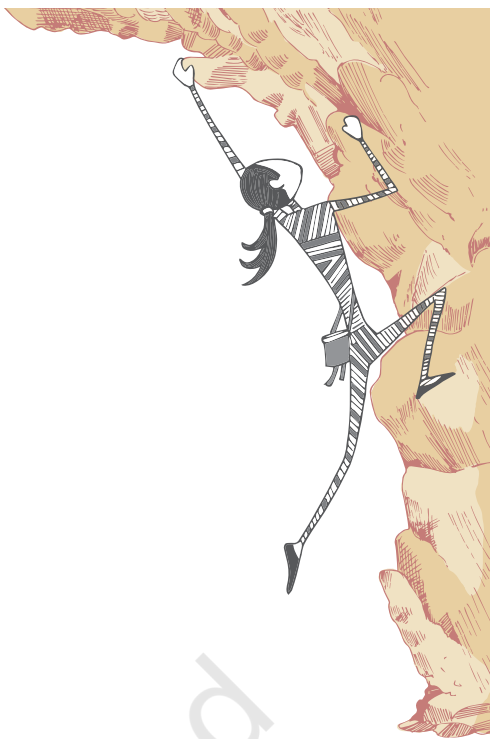

JUDO



Fig. 7.5: Player playing Judo

Judo is a popular martial art, combative and Olympic sport. In the term judo, 'ju' means 'gentle' and 'do' means 'the way or path'. Judo was developed in Japan in the late 19th century by using the principles of balance and leverage adapted from jujutsu. Its most prominent feature is its competitive element, where the objective is to either throw or putdown one's opponent to the ground, immobilise or otherwise subdue one's opponent with a grappling maneuver, or force an opponent to submit by joint locking or by executing a stranglehold or choke. Strikes and thrusts by hands and feet as well as self-defense are a part of judo. Many are trained in Judo either for participation in competition or self-defense.

History

The history of judo starts with Japanese jujutsu. It was created by Professor Jigoro Kano and he believed that the techniques could be practiced as a competitive sport if the more dangerous techniques were omitted. By 1910 Judo was a recognised sport that could be safely engaged in and in 1911 it was adopted as a part of Japan's educational system. In the same year, the Kodokan Judo Instructors' Training Department, Kodokan Black Belt Association and Japan Athletic Association were formed. World War II saw a different development of Judo. Instead of being used for sport, Judo was being taught as a combat skill. Those selected for commando and special services training often achieved a high standard of expertise. When Japan hosted the 1964 Olympics, Judo was given its first opportunity as an event. Of the 16 medals awarded for Judo, Japan won three gold medals, and one silver medal. Judo was no longer a Japanese sport but had developed to become an international sport.

There have been two main developments in Judo over the years. The first was the introduction of weight categories. Earlier everyone fought everyone else, with the result that, if two players were equally matched in skill, the bigger man usually won. Initially there were three categories, and later this was made into five. Inclusion of the sport in the Olympic Games in 1964 helped to hasten this important reform. There are different styles of Judo. With its inclusion in the Olympics, there has been a shift towards a contest style practice. In clubs where this style is taught, the practice becomes largely a continuous contest. Other schools stress on skills. They favour repetitive movements to make them instinctive and the development of speed through practice with little resistance.

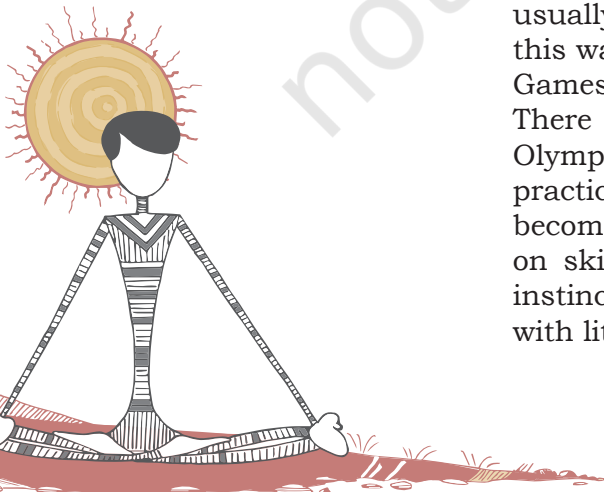

Rules

Officials

There are three officials who preside over a judo match. There is one referee who walks around inside the contest area and conducts the match. There are two judges who sit diagonally across the mat from one another, each in a corner. The two judges assist the referee and indicate when the contestant goes outside of the contest area. The referee is in charge of awarding points and accessing penalties and uses hand gestures to signal his decision. However, if a judge disagrees with a call, then the three officials take a vote and the decision is decided by a majority vote. In addition to the Judge and Referees there are also scorekeepers and timers. There is usually a scoreboard, which displays points and penalties and it can either be electronic or manual. Medical personnel are also on hand in the event of injury to a contestant.

Contestants

The two contestants, who are known as Judokas, compete for 5 minutes for men and 4 minutes for women. One contestant wears white uniform and the other a blue uniform.

Uniforms

The judokas wear loose-fitting judo uniforms called judogi, consisting of pants, a jacket and a belt. Judogi is made up of loose-fitting pants, a jacket and a belt that is tied around the waist. The jacket and pants are made of cotton. They are either blue or white and they are made so a rival should be able to get a grip on either one of them so as to be able to make a judo throw. One judoka will wear white the other blue. The belt is three meters long and it is wrapped around the waist twice. The color of the belt signifies the rank the combatant has reached.

Competition area

The entire competition area in judo is 46 to 53 feet square (14 to 16 meters). This area is made up of foam mats commonly referred to as tatami mats and the individual mats are 6.5 feet by 3.281 feet wide (2 meters long, a 1-meter wide). Inside the competition area is a contest area, which is 8-10 meters square. This contest area (shiai-jo) is green in color, that would be 29.5 feet square (9-meters) and it will have a 3.281 foot (1-meter) red boundary around it. This is the danger zone and it alerts the competitor(s) (judoka) that they are about to go out of bounds. The area outside the danger zone is the safety zone. This zone is three meters wide and it is the out-of-bounds area.

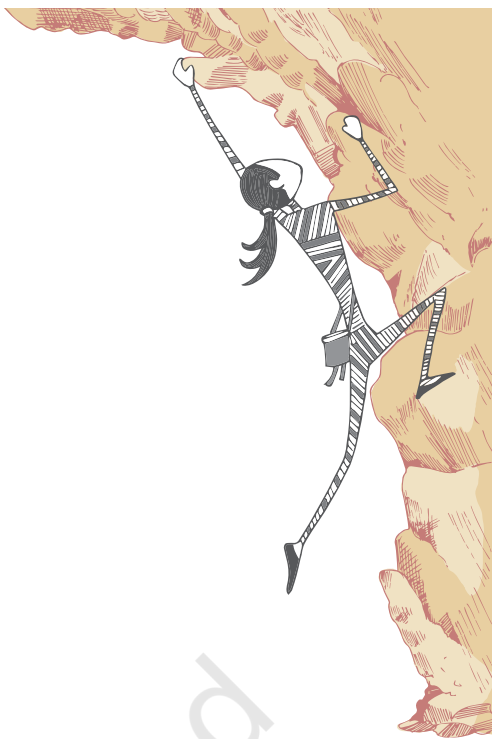

Activity 7.1

What is the proficiency given in India? Make a list.

e.g.: Yellow belt or Black belt.

In the middle of the contest area are two pieces of tape, one blue and one white 13.1 feet apart (4-meters). These two pieces of tape mark the place where the judoka will stand when they begin and end each bout.

Contest

A random draw, in the same weight category, is used to determine which contestants will be fighting each other. In the Olympic Games there are two pools, and each pool has its own single-elimination tournament. The two pool winners will compete for the gold medal, with the loser of this contest winning the silver medal. In each pool, the competitors who lose to a pool winner are then entered into a repechage round which is also a single-elimination tournament. The winners of the repechage pools will be the winners of the bronze medals.

To win the contest a Judoka must score an Ippon a score that equals 10 points by using successful Judo techniques. If neither of the Judokas is able to score an Ippon or 10 points by the end of the match, the winner will be the Judoka who has scored the most points. In the event of a tie, for the first time at the 2004 Olympic Games, the “Golden Score” rule was used. If there is no winner after the five-minute period has ended, the referee announces the beginning of “Golden Score”. This will extend the match for an extra five-minute period and the contestant who scores the first point is declared the winner of the match.

Judo penalties

Two types of penalties may be awarded. One is shido and another is hansoku. After two shido are given, the third shido becomes hansoku-make and the victory is given to the opponent. This is an indirect hansoku-make and does not result in expulsion from the tournament.

WRESTLING

Considered as one of the most ancient and oldest sport in the world, wrestling has also been equally popular in India. It is a form of combat sport involving grappling type techniques such as clinch, fighting, throws, take downs, joint locks and other grappling holds. A wrestling bout is a physical competition, between two (occasionally more) competitors or partners, who attempt to gain and maintain a superior position. There are a wide range of styles with varying rules, such as, traditional, historic and modern styles. Wrestling techniques have been incorporated into other martial arts as well as military hand-to-hand combat systems.

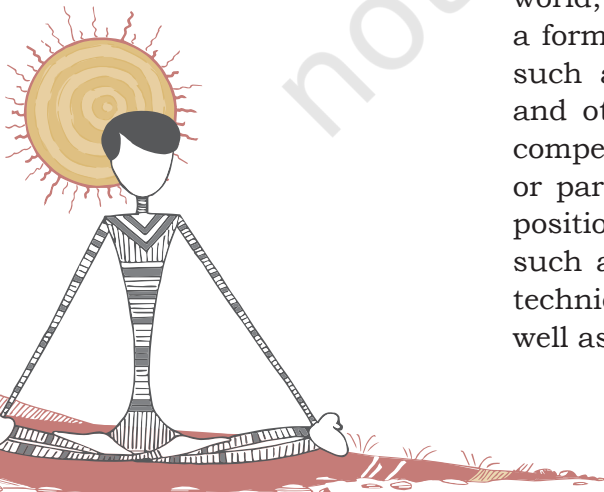

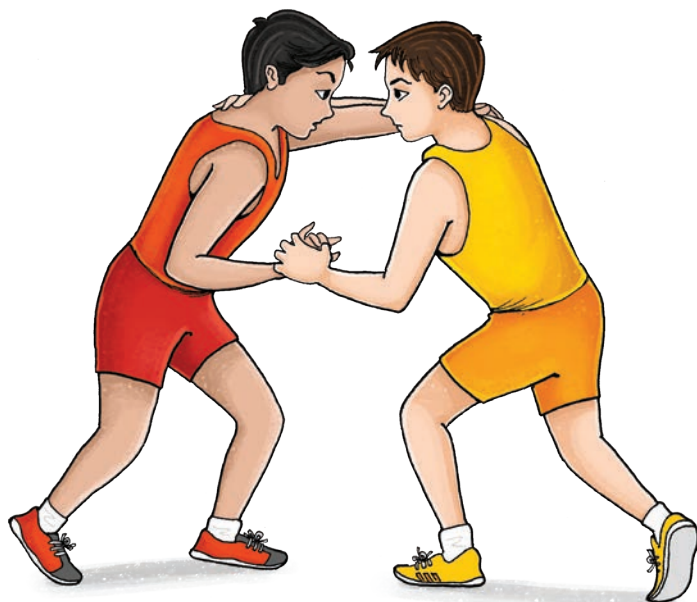

Fig. 7.6: Bout in wrestling

History

Wrestling has been a part of human society since ancient times. In India also it received regular patronage from the Emperors and Kings. Wrestling in India then was popularly known as *Malla Yuddha*. In famous Indian epic, Mahabharata, Bhima was considered to be a great wrestler of that time and some of the other great wrestlers included Jarasandha, Duryodhana, and Karna. Another Indian epic, *Ramayana* also mentions about wrestling and Hanuman is described as one of the great wrestlers of that time. Wrestling in India continued to increase its popularity during modern days. Even during the British rule, wrestling in India got encouraging support, as the British rulers included the game into the military practice. In fact, India was considered among the top 10 countries in wrestling till the 1960s. India also hosted the World Wrestling Championship at New Delhi in 1967.

The term *Kushti*, which means wrestling, denotes both a local form of the art as well as a more global combat. Kushti is composed of three primary dimensions: *dao*, *pench*, and *paintra* (moves, counter-moves, and stance). There may be similarities between the *daos* known as *multani*, *dhobi pat*, and *kalajangh* and the corresponding freestyle moves known as arm drag, front hip throw, and fireman carry. But what is significantly different about wrestling in India is that wrestlers mostly wrestle in mud pits, engage in bouts that last for half an hour or more. At other times and under other circumstances Indian wrestlers follow clearly defined international guidelines, rules, and regulations.

Do You Know?

In 2008, Sushil Kumar brought 2nd Bronze Medal for India at Beijing Olympic Games. This feat was repeated at 2012 Olympics games by Sushil Kumar (Silver Medal) and Yogeshwar Dutt Bronze Medal. The first medal was won by K.D. Jadhav in 1952 at Helsinki Games. Geeta Phogat became the first Indian woman wrestler to represent the country at 2012 London Olympic Games.

Worldwide wrestling entered a new era with the acknowledgement of Female Wrestling as an Olympic discipline in the Athens Games in 2004.

Measurement of the wrestling mat

Terms	Dimensions
Dimensions of the mat	9 meters in a circle
Empty space on the border of the mat	1 metre
Height of the platform	1.10 metre
Colour of marks on the mat	Red or Blue
Thickness of the mat	10 cm
Protection area	1.2 to 1.5 m width

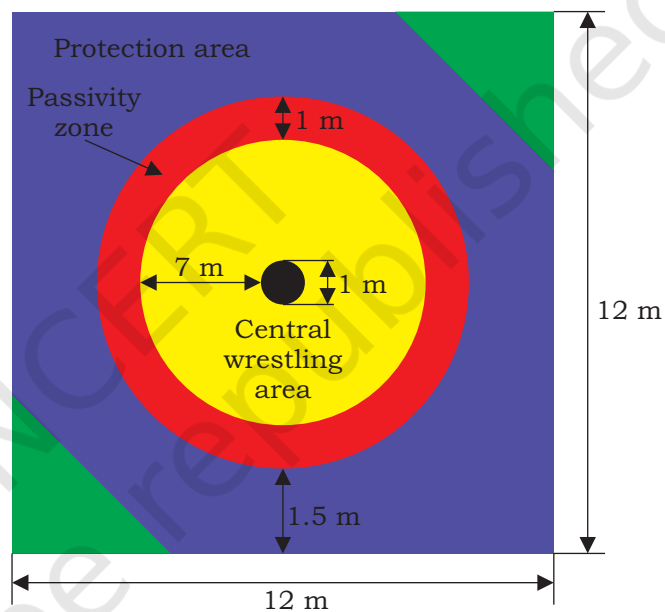
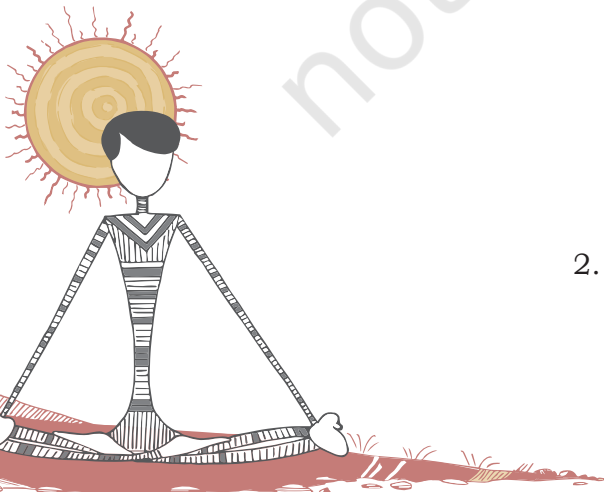

Fig. 7.7: Specifications of wrestling play area

Rules and regulations

- There are two Olympic styles of wrestling, Freestyle and Greco-Roman. With one key exception, the rules of the two styles are identical:
 - In Greco-Roman, a wrestler may not attack his opponent's legs, nor use his own legs to trip, lift or execute other moves.
 - In freestyle, both the arms and legs may be used to execute holds or to defend against attack.
- The wrestler must be at least 17 years old, and must be sponsored by the national federation, to compete at the World Championships or Olympic Games.



3. The weight divisions: There are eight weight divisions in men's international wrestling and six for women. Athletes are weighed-in prior to the competition, and must be at the weight level or below in order to participate in the competition.
4. New weight categories for wrestling (for 2018-19) —

Under-14 Boys and Girls

Freestyle (Boys)	Freestyle (Girls)
35 kg	30 kg
38 kg	33 kg
41 kg	36 kg
44 kg	39 kg
48 kg	42 kg
52 kg	46 kg
57 kg	50 kg
62 kg	54 kg
68 kg	58 kg
75 kg	62 kg

Under-17 Boys and Girls

Freestyle and Greco-Roman (Boys)	Freestyle (Girls)
41-45 kg	36-40 kg
48 kg	43 kg
51 kg	46 kg
55 kg	49 kg
60 kg	53 kg
65 kg	57 kg
71 kg	61 kg
80 kg	65 kg
92 kg	69 kg
110 kg	73 kg

Under-19 Boys and Girls

Freestyle	Freestyle (Girls)	Greco-Roman (Boys)
57 kg	50 kg	55 kg
61 kg	53 kg	60 kg
65 kg	55 kg	63 kg
70 kg	57 kg	67 kg
74 kg	59 kg	72 kg
79 kg	62 kg	77 kg
86 kg	65 kg	82 kg

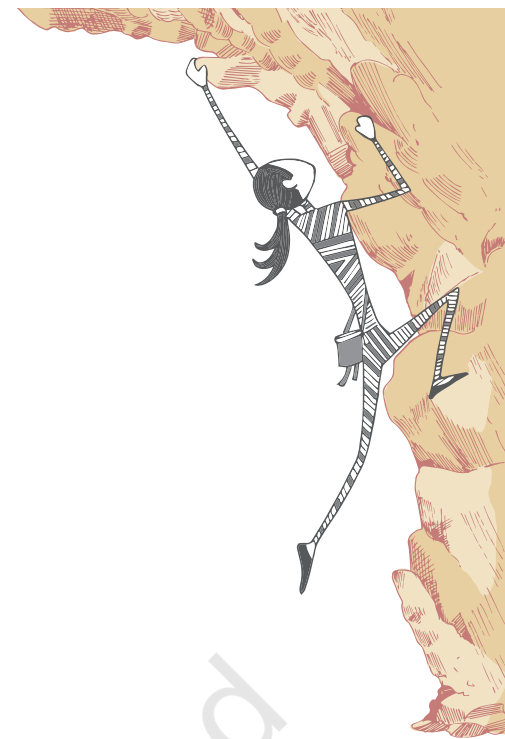

92 kg	68 kg	87 kg
97 kg	72 kg	97 kg
125 kg	76 kg	130 kg

5. The officials: There are three officials for every international wrestling match, a referee (on the mat) plus a chairperson and a judge. There cannot be two officials from the same nation officiating the same match, nor may an official officiate a match where an athlete from his/her nation is participating. The officials award points on a majority vote. At least two of the three officials must agree on technical points and falls.
6. The coach: The coach may remain at the foot of the platform or at least two meters from the edge of the mat during the competition.
7. The uniform: Wrestlers must wear a one-piece singlet, in the color assigned to them (red or blue), wrestling shoes and carry a handkerchief. The wrestling singlet must be of a type approved by the international wrestling federation. Referees must wear a white shirt or pullover, pants and shoes.
 - o The competition rules: You have already gone through these rules in Class IX, Chapter 10 *Team Games*.

Scoring rules and terms

- Takedown occurs when a man takes opponent to the mat from a standing position. This is worth one point, but can be worth more if the opponent is brought down onto his back.
- Exposure is turning an opponent's shoulders to the mat. Once the line of the back area breaks a 90-degree angle, points are scored. This can occur both from the feet and on the mat. A wrestler who holds his opponent in a danger position for five seconds will receive one extra point.
- Reversal is, when the man underneath completely reverses his position and comes to the top position in control, he has scored a reversal, worth one point.
- Escape is when an athlete works to come out from the bottom position (after being under dominant control) and gets to their feet, facing the rival. The athlete has then scored an escape, worth one point.
- Duration of the bout U-15 cadets and veterans — The duration of a bout will be of two periods of 02 minutes with a 30 second break.

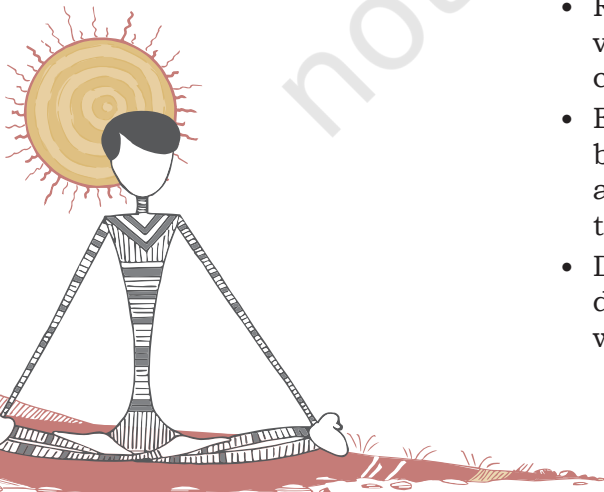

- Junior and seniors — The duration of a bout will be two periods of 3 minutes each with a 30 second break.

For all the competitions, the timing displayed on the scoreboards will start from 6 to 1 minute (from 4 to 0 minute for U-15, cadets and veterans).

Scoring

Points	Terms
1 point	Holding of opponent on the ground
2 points	Placing the opponent in danger
3 points	Bringing the opponent into immediate danger position
4 points	Exceeding a throw of great height losing contact of the other opponent from the ground.
5 points	All grand amplitude throws executed in a standing position which bring the defending wrestler to a direct and immediate danger position. The hold executed by a wrestler in the <i>Parterre</i> position who completely lifts his opponent off the ground with the execution of a high amplitude throw which project the opponent into a direct and immediate danger position.
Fall	Bring two shoulders of the opponent on the ground.

Types of Victories

A bout may be won	by fall
	by injury
	by a disqualification
	by points (by having at least 1 point more after addition of the two periods)
In case of tie by points, the winner will be declared by successively considering	The highest value of holds.
	The least amount of cautions.
	The last technical point/points scored.



ASSESSMENT

KABADDI

I. Answer the following Questions

1. List the landmarks in the history of Kabaddi in India.
2. What is the system of scoring in Kabaddi?
3. What are the rules regarding substitutions?
4. What is a bonus point?
5. What is the Golden Raid rule?

II. Fill in the Blanks

1. The Kabaddi court measures _____ meters with a dividing line in between making it into identical halves.
2. Each team consists of minimum _____ and maximum _____ players, but only _____ players take the ground at a time.
3. The duration of the match is two halves of _____ minutes with _____ minutes interval in case of men and junior boys and of _____ minutes with _____ minutes interval in the case of women and junior girls.
4. Each team shall be allowed to take _____ “time outs” of _____ seconds each in each half.

KHO-KHO

I. Fill in the Blanks

1. In Kho-Kho, one team becomes the _____ and the other the _____ or runners.
2. Many historians say that Kho-Kho is actually a modified form of ‘_____’.
3. The first ever book of Kho-Kho rules was published from Gymkhana Baroda, in _____.
4. The year 1936 got the golden opportunity for the game of Kho-Kho when _____ featured an exhibition of Kho-Kho in the main stadium.
5. The first ever All India Kho-Kho Championships were organised at _____ in 1959-60 under the auspices of _____ of India.
6. The Indian Olympic Association has included kho-kho as a discipline in the next _____ Games to be held in New Delhi in _____.

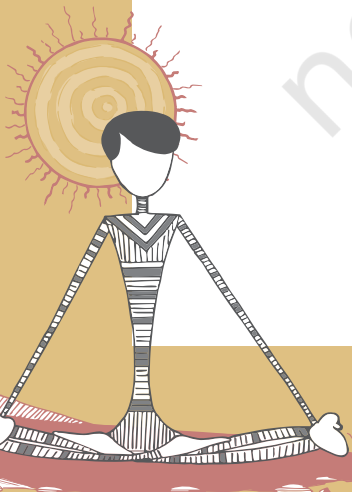

II. State whether True or False

1. In Kho-Kho, each team consists of 15 players, but only 12 players take the field for a contest
2. A match consists of 4 innings. An innings consists of chasing and running turns of 9 minutes each.
3. The chasers can only run in one direction and cannot cut across the sitters unlike the dodgers who can run randomly and in between the sitters.
4. The equipment used in Kho-Kho are posts, two watches, and score board.
5. A Kho-Kho playground (or pitch) is rectangular. It is 29 meters in length and 16 meters in width.
6. One side of the rectangle is 20 meter and the other side is 9 meters.
7. At the end of the innings there is an interval of 5 minutes and an interval of 2 minutes, in between the turns.

JUDO

I. Answer the following Questions

1. Briefly list the typical characteristics of Judo?
2. Why should we learn Judo?
3. How has Judo developed in India?

II. Fill in the Blanks

1. There is one _____ who walks around inside the contest area and conducts the match and there are _____ judges who sit diagonally across the mat from one another, each in a corner.
2. Contestants, who are known as _____, compete for _____ minutes for men and _____ minutes for women.
3. The judoka wears loose-fitting judo uniforms called _____ because _____.
4. The entire competition area in judo is _____ to _____ square feet (14 to 16 meters).
5. In the middle of the contest area are two pieces of tape, one _____ and one _____.
6. To win the contest a Judoka must score an _____ a score that equals 10 points by using successful Judo techniques.
7. Penalty points can also be awarded against a Judoka. These penalties are: _____, _____ and _____.

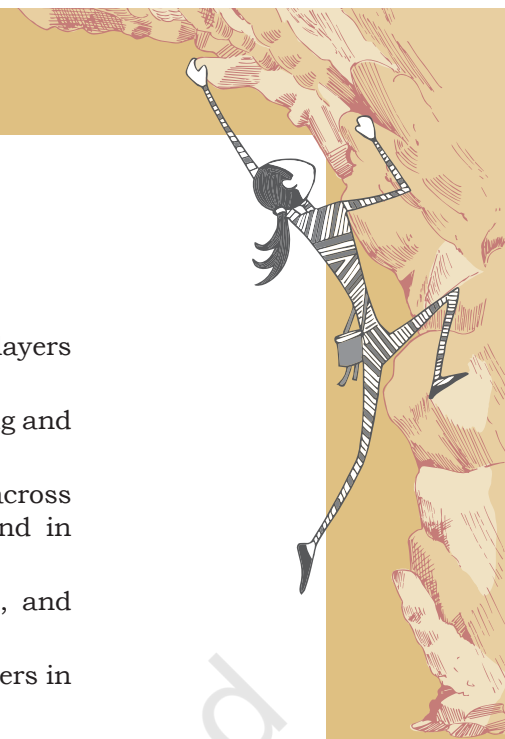

WRESTLING

I. Answer the following Questions

1. List the landmarks in the history of wrestling in India?
2. List and describe the scoring rules and terms of wrestling.

II. Fill in the Blanks

1. It is a form of combat sports involving grappling type techniques such as _____, _____, _____, _____, _____ and other grappling holds.
2. In Greco-Roman, a wrestler may not attack his/her opponent's _____, nor use his/her own _____ to trip, lift or execute other moves.
3. In freestyle, both the _____ and _____ may be used to execute holds or to defend against attack.
4. International wrestling is contested on a mat, with a _____ meter circular competition area.
5. There are three officials for every international wrestling match, a _____ (on the mat) plus a _____ and a _____.
6. If a wrestler scores _____ points more than his opponent at any time, the round is stopped.

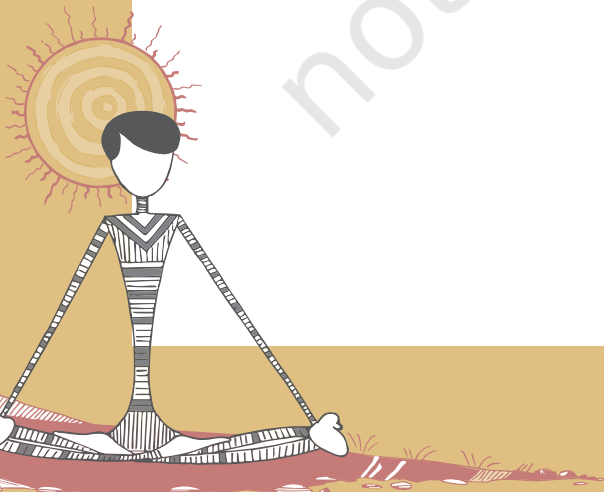

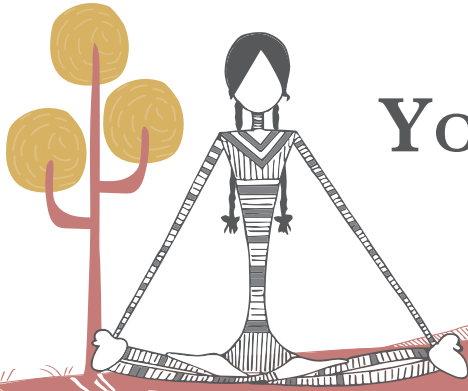

YOGA FOR HEALTHY LIVING



Adolescents in different situations experience a wide range of emotions that could vary from positive to negative, such as, happiness, satisfaction, sadness, anger, frustration, etc. They have high expectations from themselves that may be further reinforced by people and environment around them. This may cause stress in them. There are many occasions when they may get stressed or feel angry or frustrated. It is natural for adolescents to experience both positive and negative emotions. It is also necessary to express their feelings and emotions. There are positive and negative ways of expressing the emotions. It is pointed out that negative emotions and their expression in negative ways may be caused by certain stresses experienced by the adolescents.

In today's life, stress is becoming a major cause of many health-related problems. It is a known fact that chronic stress negatively affects health. Hypertension, diabetes mellitus, cardiac problems, depression, anxiety attacks, road-rage, etc., have become common now-a-days. The most common emotion faced by all of us during this COVID-19 pandemic is fear. It has also made us panicky and anxious to deal with such issues. Yoga can help us in dealing with stress and mental health issue during this time. In the management of stress, lifestyle plays an important role. A healthy lifestyle reduces stress and promotes one's health.

Here, it is important to recognise that stress can be tackled and definitely decreased. Many times, we may not necessarily be in control of the situations but we can control our over-all response to such situations.

WHAT IS STRESS?

Stress can be understood as a state of physiological and psychological imbalance resulting from demanding or difficult situations which the person is not able to cope with.



1077CH08

Activity 8.1

Think and discuss the following with your friends:

Questions

- Have you ever experienced stress?
- What was the cause of it?
- How did you manage it?
- Can you think any other way by which you could have better managed it?

In day-to-day life, a person faces many situations. Some situations are easy to handle; while some are difficult. As a result, the body starts responding at physiological and psychological levels. At the physiological level, there may be changes in heart rate, pulse rate, blood pressure, secretions of hormones, etc. At the psychological level, there may be changes in attention, concentration, memory and alertness and also in the emotional state (like anger, fear, hate, sadness, etc.).

Stress generally occurs as a result of major events in life, such as, tough competitions, getting low scores in an examination, recent break-up in friendship, not getting a good job, a fight with others, and so on. There are several other factors which may cause stress in a person, like, diseases, poor living conditions, poverty, problems in relationship, challenges of adolescence, wrong habits, high aspirations, unrealistic goals, death of a close relative, discrimination, fast changing life and many others. However, sometimes it may also occur due to minor issues, such as, not getting up early, not getting ready on time, reaching school late, not getting the desired food, arguments with a friend, not getting permission from parents for attending a late night party, and so on.

Intensity of stress varies from person to person and generally depends on perception of a particular situation by that person. A situation may be easy to handle for one person, while it may pose a big challenge to another. For example, examination may cause stress in one student, while it may not affect another student.

Stress which motivates us to perform better and learn new skills is beneficial. For example, getting admission in a new course, preparing for an examination or getting promotion may cause stress but this stress is beneficial as it finally contributes towards growth and development. Stress may be harmful also. When stress is severe and chronic it reduces efficiency of a person. This kind of stress may adversely affect our ability to feel, think and act.

During severe stress, people may become restless and worried. They may not remember the things properly. Even small things may make them angry. You also might have observed that when you are in tension you become restless. You may not be able to focus on your studies and small things may cause irritation.

Chronic and severe stress reduces our body's ability to fight diseases. It can lead to various psychosomatic diseases, such as, peptic ulcer, migraine, diabetes mellitus, high blood pressure, etc. It could even result in heart attack, brain stroke and death. Several psychological disorders, such as, anxiety attacks and depression may

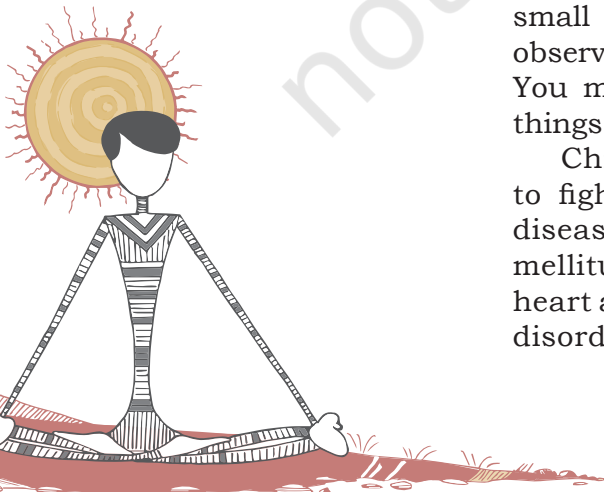

also result from chronic and severe stress. However, the fact is — we cannot avoid stress. Therefore, management of stress is necessary

YOGA AS A WAY OF LIFE FOR STRESS MANAGEMENT

Yoga has been considered a panacea for managing the stress. In this context, we will discuss the role of yoga in developing a healthy lifestyle by which stress can be managed. Yoga practices when become a way of life, play an important role in stress management.

You have learnt about *asana*, *pranayama*, *kriya*, *mudra*, *bandha* and meditation in Class IX. However, yoga is not limited to the physical postures, breathing techniques or meditation for a few minutes only. Rather yoga is a way of life also. It propounds several principles and practices, such as, *asana*, *pranayama*, *kriya*, *mudra*, *bandha* and meditation which are relevant to healthy living. Yogic principles and practices of healthy living can be adopted by all, irrespective of age, gender, profession or place. As a way of life, yoga gives direction about food, eating habits, thinking, recreational means and conduct. Yogic way of life, if adopted in true sense, empowers us to deal with stress and promote physical and mental health.

The components of yogic way of life are —

- *Ahara* (Food)
- *Vihara* (Relaxation)
- *Achara* (Conduct)
- *Vichara* (Thinking)
- *Vyavahara* (Behaviour or actions)

Ahara

The principles of *ahara* are related to food consumption. Yoga emphasises on *mitahara*, which is related to quality and quantity of food and also the state of mind during the intake of food.

As for the quality, the concept of *mitahara* implies that food should be freshly cooked, nutritious, nourishing and in the natural form. Regarding quantity of food, *mitahara* mentions that two quarters of the stomach should be filled with food, one quarter with liquid and the remaining quarter (one-fourth) should be left empty for free flow of air. This implies that quantity of food may vary from person to person depending upon the individual requirements. It is very natural that a sportsperson will require more food as compared to a person who is doing desk job. *Mitahara* also advocates that the food should be eaten with positive state of

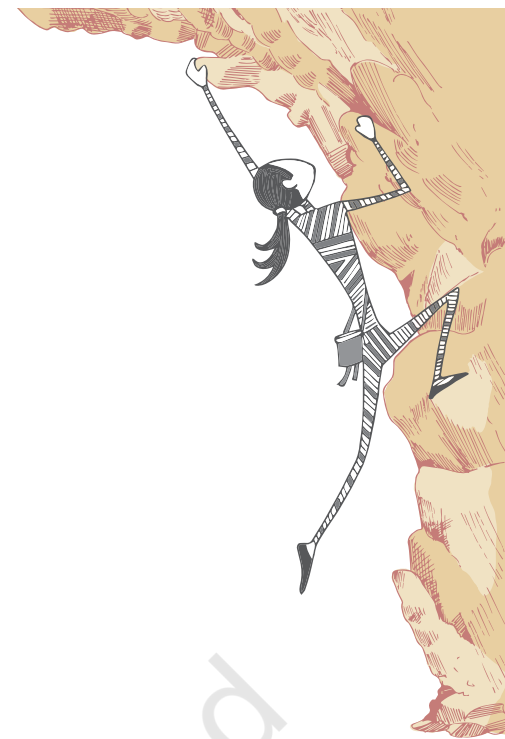

mind with utmost concentration. You might have observed if someone eats while watching the television or in an angry mood or when the person's attention is somewhere else, then they tend to just gulp down the food without enjoying it. So, the state of mind is also very important while eating. Thus, *mitahara* emphasises that right quality and quantity of food should be eaten in a positive state of mind.

Activity 8.2

In Column I, put a list of food items that you like eating and in Column II put the food items that you consider good for your health.

Column I Food items that you like eating	Column II Food items that you consider good for health

Questions

- Compare the items of both the columns. Do the items in Column I tally with those in Column II?
- Do you think that you need to change your food habits? Make a separate list indicating which food items from the list (Column I) you want to change.

Vihara

Vihara means relaxation, which can be brought about by activities, such as, exercise, recreational and creative activities like drawing, painting, singing, etc. These activities help to regulate and channelise our emotions and bring us joy and happiness. Yogic practices of *asana*, *pranayama* and *meditation* relax body and mind. In addition to this, relaxation can be attained in good company also. Sound sleep is also important for relaxation. It is, therefore, important that we should regularly follow a timetable that provides adequate time for yogic and creative activities which are relaxing.

136

Activity 8.3

Prepare a timetable that allots some leisure time to pursue your hobbies and creative activities, exercise and sufficient time for sleep.

Time allocated	Activities
• 5.30 to 6.30 pm	• Yogasana
• _____	• _____
• _____	• _____

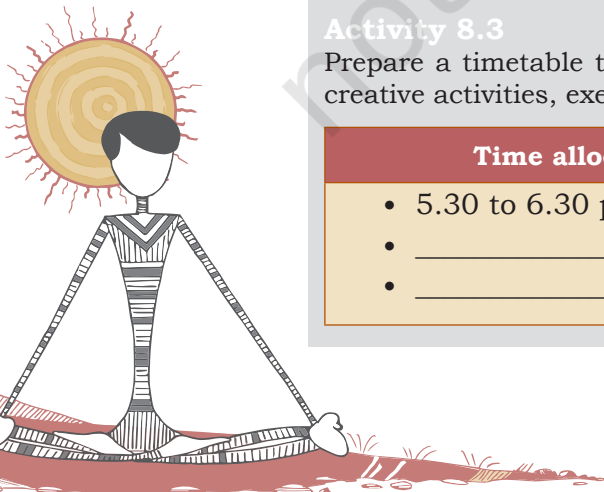

Achara

Achara means conduct that includes emotions, attitudes, desires, instincts and habits. Right conduct is essential for a stress-free life. Positive emotions and positive attitudes, good habits and control on desires help in making us strong, both, individually and socially. The right conduct protects us from unnecessary stress caused by negative emotions and attitudes like hate, jealousy, fear, etc.

Therefore, we should have control on our desires, instincts, emotions, habits and attitudes. Here, yoga is important as it encourages good conduct in our personal and social life. Yoga advocates for positive emotions and positive attitude towards self and other persons.

In this context yogic principles of *Yama* (restraint) and *Niyama* (observance) help to develop control on our desires and emotions and bring about peace and harmony.

Yama (Restraint) and Niyama (Observance)

Yamas (restraints) and *Niyamas* (observances) are sets of the dos and the don'ts. They can be considered as the universal codes of conduct that help us in following high standards in our personal and social life. *Yamas* are concerned with one's social life; while the *niyamas* are concerned with one's personal life. *Yama* and *Niyama* are part of *Ashtanga* Yoga that has been propagated by Patanjali.

The **five** *yamas* are *ahimsa* (non-violence), *satya* (truthfulness), *asteya* (non stealing), *brahmcharya* (celibacy) and *aparigraha* (non possessiveness).

The **five** *niyamas* are: *Shaucha* (cleanliness), *Santosha* (contentment), *Tapas* (austerity), *Swadhyaya* (self study) and *Ishwarpranidhana* (surrender to god).

Vichara

We know that thoughts are very important as our behaviour is guided by the kind of thoughts we have. Our thinking should be positive.

Positive thoughts bring pleasure to our life; while negative thoughts can make us unhappy. Right thinking guides us towards appropriate behaviour. It helps in prevention and management of stress-related health problems.

Yoga prescribes that one should have positive thoughts. Positive thoughts give us strength to bear the sorrows of life. Yogic practices like *yama*, *niyama*, *pratyahara*, *dhyana* (meditation), study of good literature, etc., help us in controlling our thoughts and thereby promoting optimism in life.

Activity 8.4

Ramesh and his friends are planning to skip their classes and go for a movie instead. Ramesh is worried as he feels that it is not right to skip the class without informing his parents. But at the same time, he does not want to be seen as a spoilsport by his friends. Finally, he succumbed to the peer pressure. Now, he is disturbed to think what would happen if his parents come to know of it.

Questions

- Why was Ramesh worried?
- Was his conduct appropriate? Explain your answer.
- Can you suggest some ways to get out of this conflicting situation?
- What would you do, if you were in Ramesh's place?
- Do you think the yogic principles of *Yama* (restraint) and *Niyama* (observance) help to develop control on our desires and emotions and lessen our stress?



Activity 8.5

Write your thoughts about various people in the appropriate columns in the table given below.

People	Positive Thoughts	Negative Thoughts
Teachers		
Parents		
Bench partner in the class or your friend		

Questions

On the basis of your thinking, as given in the above table, answer the following questions:

- Find out which type of thoughts — positive or negative — were dominating you today?
- Do you feel that you need to change your thoughts? If yes, why?

Activity 8.6

Shreya is an outgoing and independent girl. She does not like to be dictated by her parents. Her parents are worried as they think that she has been wasting her time and energy on futile, trivial and useless things. One day, her parents asked her to study while she wanted to finish the novel which she was reading. At this, Shreya lost her temper and started shouting at her parents.

Questions

- Was Shreya's behaviour towards her parents appropriate?
- Were her attitude and thinking responsible for this kind of behaviour?
- Suggest how she should have behaved.

Vyavahara

Vyavahara (behaviour) means actions. *Vyavahara* is the result of *ahara*, *vihara*, *achara* and *vichara*. Yogic philosophy propounds that our actions should be right. We should not indulge in wrong activities. Our behaviour towards others should be appropriate. *Karma-yoga* proposes that we should perform right and act with full dedication and to our utmost capacity without worrying about the results. We can remain stress-free and be happy if we follow this philosophy and act accordingly.

YOGIC PRACTICES

The practices which can strengthen the autonomic nervous system with the dominance of para-sympathetic system of body are beneficial for managing stress. Here are some *asanas*, *pranayamas*, *kriya* and relaxing practices which are helpful in stress management.

ASANA**Hastottanasana**

Hastottanasana comprises of three words— *hasta*, *uttana* and *asana*. *Hasta* means 'arms'; *uttana* means 'stretched up' and *asana* means 'posture'. In this posture, the arms are stretched upwards, hence is called *Hastottanasana*.

Let us perform *Hastottansana* by following the steps given below.

1. Stand erect on the ground with both feet together.
2. Slowly inhaling, raise both arms over the head.
3. Interlock the fingers and turn the palms upward.



4. Exhaling, bend from the waist towards the right side. Maintain this position comfortably for 5-10 seconds in the beginning.
5. Inhaling, come to the centre.
6. Repeat it from the left side as well.

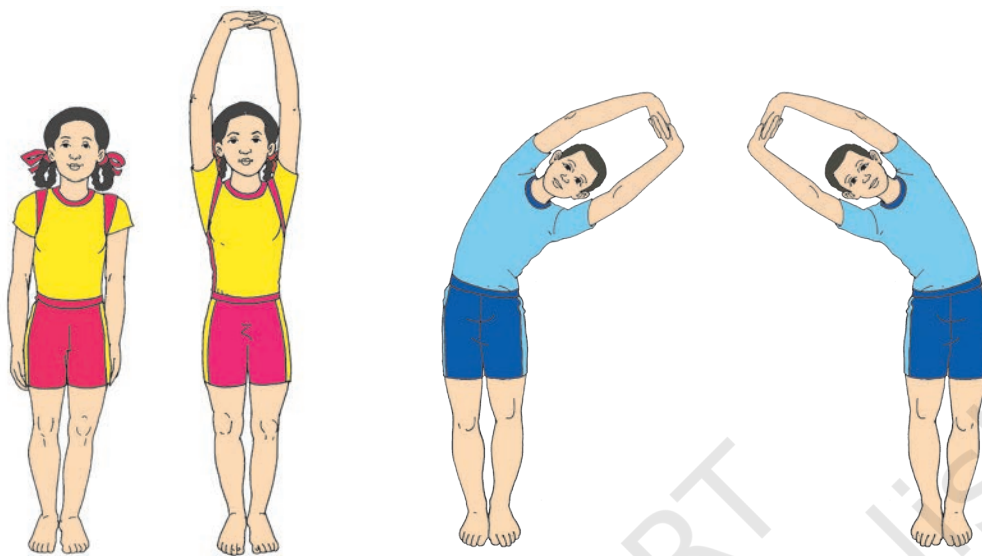

Fig. 8.1: Hastottanasana

Remember the following points

Dos	Don'ts
<ul style="list-style-type: none"> • Bend from the waist only. • Stretch the arms up as much as possible. 	<ul style="list-style-type: none"> • Avoid bending forward.

Benefits

- It relaxes the whole body.
- It relieves pain in the neck, shoulders and arms.
- It is beneficial for increasing the height of growing children.
- It increases flexibility of the spine.

Limitation

- This *asana* should not be performed in case of hernia, abdominal inflammation.

Padahastanasana

Padahastanasana consists of three words: *pada*, *hast* and *asana*. In Sanskrit *pada* means 'feet', *hast* means 'arms' and *asana* means 'posture'. In this *asana*, the hands are brought near the feet, hence it is called *Padahastanasana*. It strengthens the organs located in the abdominal area and improves their functioning.



Fig. 8.2: Padahastanasana

Let us perform *Padahastasana* by following the steps given below.

1. Stand erect, keep both feet together with hands beside the body. Balance weight of the body on the sole of the feet.
2. Inhaling, raise both arms above the head and stretch them up.
3. While exhaling, bend forward from the waist. Place the palms on the floor beside the feet or touch the feet with palms.
4. Maintain this position comfortably for 10–15 seconds.
5. To come back, slowly come to the standing position keeping your arms up over the head. Then slowly bring the arms down to the starting position.

Remember the following points

Dos	Don'ts
<ul style="list-style-type: none"> • Keep the legs straight. • Keep the arms straight and bring them down along the head while bending down from the waist. 	<ul style="list-style-type: none"> • Do not bend the knees.

Benefits

- It improves digestion.
- Liver and spleen are activated by this *asana*.
- Abdominal muscles are toned by this *asana*.
- It improves circulation of blood to the head and upper region of the body.
- It increases the flexibility of the legs' muscles.

Limitations

- In case of severe backache and high blood pressure one should avoid this *asana*.

Trikonasana

Trikonasana is made of two words— *trikona* and *asana*. *Trikona* in Sanskrit means 'triangle'. In this *asana*, the body assumes the shape of a triangle, hence it is named *Trikonasana*. This *asana* helps to manage stress by strengthening the abdominal organs and the muscles in legs, trunk and buttocks.



Fig. 8.3: *Trikonasana*

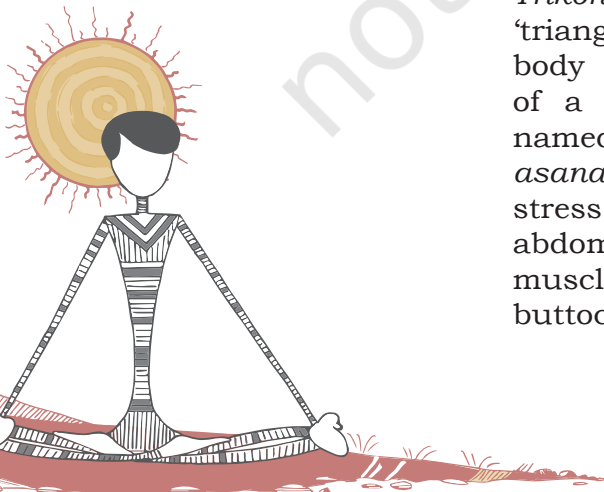

Let us perform *Trikonasana* by following the steps given below.

1. Stand erect with legs together, hands by the side of the thighs.
2. Move your legs 2-3 feet apart.
3. Raise the arms sideways and bring them to shoulder level, parallel to the floor, so that they are in one straight line.
4. Turn the right foot to the right side at 90° angle.
5. Bend from the waist to the right side, taking care not to bend the body forward.
6. Place the right hand on the right foot. If possible, the right palm can rest on the floor also. Keep the two arms in line with each other.
7. Lower the left arm over the ear until it is parallel to the floor with palm facing down. Now look up at the left hand.
8. Maintain this position with normal breathing comfortably for 5–10 seconds.
9. To come back, lift the right palm. Raising the trunk bring the arms sideways in line with the shoulders. Bring down your arms and keep the hands by the sides of thighs. Bring your feet together and relax.
10. Repeat the *asana* from other side.

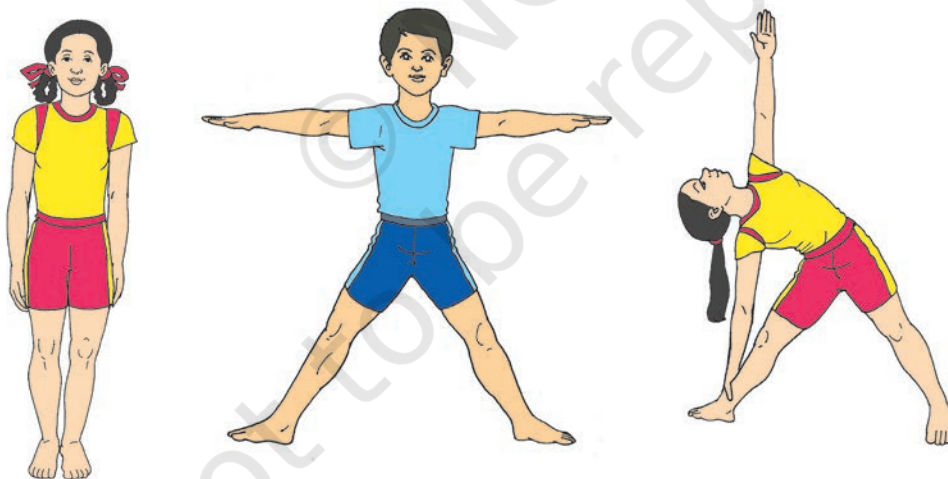
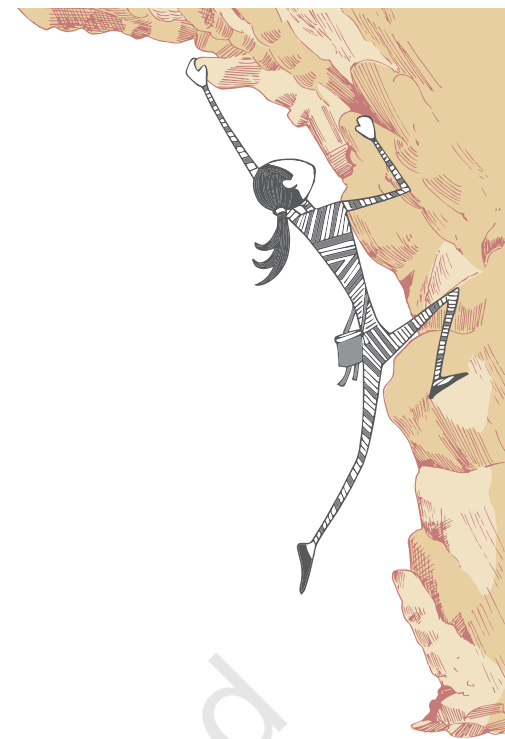

Fig. 8.4: (a) *Hastotanasana*, (b) *Trikonasana* pose 1 and (c) *Trikonasana* pose 2

Remember the following points

Do's	Don'ts
<ul style="list-style-type: none"> • In final position, the back of the legs, the back of the chest and the back of the hips should be in a line. • Maintain the final posture with normal breathing. 	<ul style="list-style-type: none"> • Do not bend the knees while bending sideward. • Do not lean forward or backward while performing this asana.



Benefits

- It tones up the muscles in trunk, legs and hips.
- It improves the flexibility of spine.
- It invigorates the abdominal organs.
- It is effective for increasing the height of growing children.
- It relieves the pain in the neck and back.
- It is beneficial for the person suffering from sciatica.

Limitation

- Practice of this *asana* should be avoided in case of backache and abdominal inflammation.



Fig. 8.5: Shashankasana

Shashankasana

This *asana* is made of two words: *Shashanka* and *asana*. *Shashanka* in Sanskrit means hare. In the final position of this *asana*, the body resembles the shape of a hare, hence, it is called *Shashankasana*. This *asana* helps to regulate the functioning of the organs of the endocrine system especially the adrenal glands

and the pancreas located in the abdominal and pelvic regions of the body. These glands produce hormones and play a vital role in energy allocation.

Let us perform Shashankasana by following the steps given below.



Fig. 8.6: Vajrasana

1. Sit in *Vajrasana*.
2. Inhaling, raise both arms over the head.
3. Exhaling, bend forward from the waist keeping the head and arms straight in line with the trunk.
4. Place the forehead and arms on the ground. Close the eyes.
5. Stay in this position for 5-10 seconds or as long as you feel comfortable.
6. To come back, raise your arms and trunk; and slowly come in the *Vajrasana* pose.

Remember the following points

Dos	Don'ts
<ul style="list-style-type: none"> • Bend from the waist only. • In the final position, the forehead should be placed between the arms. 	<ul style="list-style-type: none"> • Do not bend the arms while bending down.

Benefits

- It relaxes the body and helps in reducing the stress.
- It improves the functioning of liver, kidneys and other visceral organs.

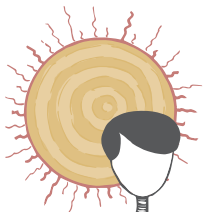

- It tones up reproductive organs.
- It is effective in the management of diabetes mellitus and sciatica.

Limitation

- Persons suffering from backache and cervical spondylitis should avoid this *asana*.

Ushtrasana

In Sanskrit, *Ushtra* means ‘camel’. In the final position of this *asana*, the body resembles a camel. Hence, this is called *Ushtrasana*. This *asana* should be practised before *shashankasana* and *paschimottan asana*.

Let us perform *Ushtrasana* by following the steps given below

1. Sit in *Vajrasana*.
2. Stand on the knees with toes pointing backward and resting on the floor.
3. Inhaling, bend backward giving the spine a backward bend.
4. Place the palms on the respective heels or soles.
5. Keep the head tilted backwards.
6. Maintain the posture comfortably for 5 -10 seconds.
7. To come back, release the hands one by one, bring the head, neck and chest back to the normal position and slowly come to the *Vajrasana*.

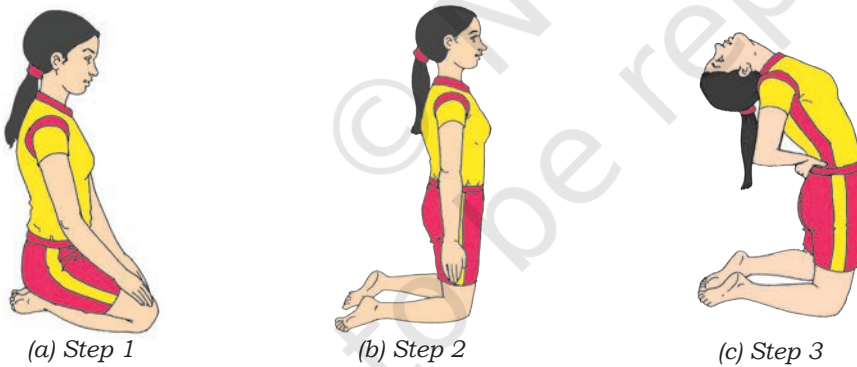

Fig. 8.8: Ushtrasana Steps

Remember the following points

Dos	Don'ts
<ul style="list-style-type: none"> • Place palms on soles or heels carefully and keep the arms straight. • Contract the buttock and stretch the dorsal region of back when bending backwards. • In the final position, thighs should be perpendicular to the floor; and head should be tilted backwards. • Weight of the body should be supported by legs and arms. 	<ul style="list-style-type: none"> • Do not jerk the neck while assuming and releasing the posture. • Do not bend the spine forcefully beyond the capacity.



Fig. 8.7: Ushtrasana

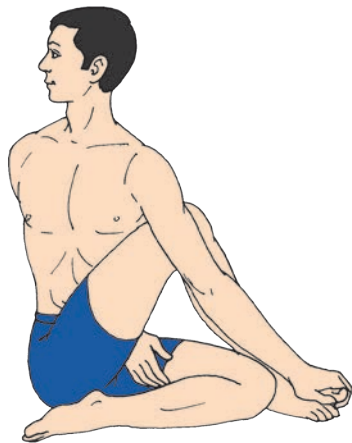

Fig. 8.9: Ardhamatsyendrasana

Benefits

- It is beneficial for people with drooping shoulders and hunched back.
- It helps to regulate the functions of the endocrine system especially the thyroid glands.
- It helps to tone the entire digestive system as well as excretory system.
- It makes the spine flexible; loosens up the vertebra and stimulate spinal nerves.

Limitation

- Avoid practising this *asana* in hernia, abdominal complaints, severe arthritis and vertigo.

Ardhamatsyendrasana

Ardhamatsyendrasana is a milder version of the *Matsyendrasana* which is named after Yogi Matsyendranath. *Ardha* means 'half'. The original *Matsyendrasana* is difficult to practise, hence its easier version called *Ardhamatsyendrasana* is generally practised. In *Ardhamatsyendrasana*, the spine is given the maximum lateral twist.

Let us perform *Ardhamatsyendrasana* by following the steps given below.

1. Sit on the ground with legs extended in front.
2. Bend the knee of the left leg, place left foot close to the right buttock, heel touching the side of the hip and the left knee touching the ground.
3. Bend the right knee; and place the right foot flat on the ground near the outer side of the left knee. Toes of the right foot should face forward.
4. Place left arm over right knee in such a way that it covers the outer side of the right knee. Hold the right foot or ankle with left hand. The right knee should be close to the left armpit.
5. Bend the right arm from the elbow and take it behind and encircle the waist as much as possible as if trying to touch the navel.
6. Turn the head towards the right side. Try to look behind over the shoulder.
7. Stay in this position for 5-10 seconds.
8. To come back, bring your head to the centre. Bring the right arm in the front. Similarly, bring the left arm, right leg and left leg to the starting position. Repeat it for the other side.

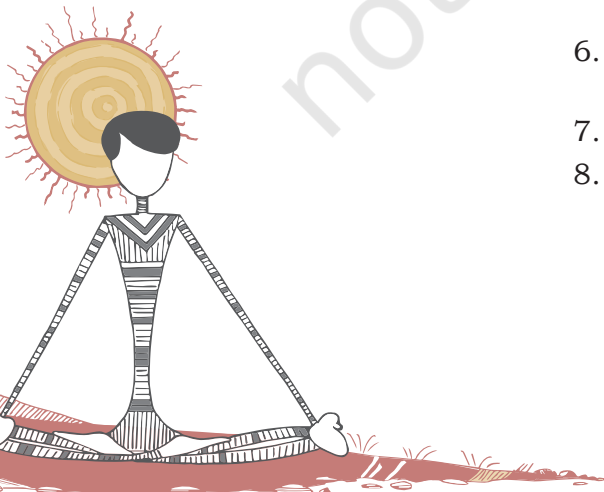

Remember the following points

Dos	Don'ts
<ul style="list-style-type: none">• Twist the spine with support of the arm.• Toes of the foot kept near the outside of knee should be facing forward.• The outside edge of the foot which is kept near the buttock should touch the floor.• Sit as straight as possible.• While twisting the spine, simultaneously move the arm, trunk and head.	<ul style="list-style-type: none">• Do not give jerk to the spine.• Do not strain the back.

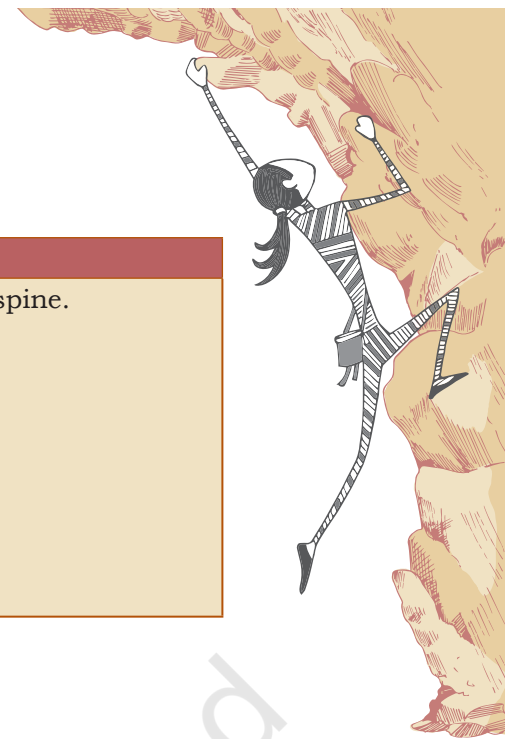

Benefits

- It stimulates liver, spleen and pancreas and helps to regulate their functioning.
- It benefits intestines also.
- It enhances movements of the shoulders.
- It rejuvenates the nerves around the navel.
- It is useful for persons suffering from diabetes mellitus and lower back pain.
- It strengthens the spinal column and the muscles of the back.

Limitation

- People suffering from peptic ulcer, hernia and severe arthritis should avoid this practice. People with sciatica or slipped disk should be cautious and seek expert advice.

Bhujangasana

Bhujangasana or Cobra Pose is very helpful in stress management. In *Bhujangasana* the organs of endocrine system especially the adrenal glands and pancreas are activated and strengthened.

Let us perform *Bhujangasana* by following the steps given below.

1. Lie prone on the ground with forehead touching the floor; legs together, hands by the side of thighs.



Fig. 8.10: *Bhujangasana*



Fig. 8.11: *Bhujangasana*

2. Fold the hands at elbows and place the palms by the side of the shoulders, thumbs under armpits, with tip of the fingers not crossing the shoulder line.
3. Inhaling, slowly raise the head, neck and shoulders. Shoulders should be shrugged backwards.
4. Raise the trunk up to the navel region. Raise the chin as high as possible.
5. Eyes should be kept gazing upward.
6. Maintain the position for 5-10 seconds or as long as comfortable.
7. To come back, bring down the upper part of navel region, chest, shoulders, chin and head.
8. Place the forehead on the ground and arms along the body, hands by sides of the thighs. Relax.

Remember the following points

Dos	Don'ts
<ul style="list-style-type: none"> • Put minimum weight on hands. • Distribute weight on the back. • The trunk should be raised up to the navel only. • While raising, shoulders should be shrugged backwards. 	<ul style="list-style-type: none"> • Do not give jerk to lift the body. • Do not allow the elbows to spread out. • Do not raise the region beyond the navel region.

Benefits

- It affects the spinal column and makes it flexible.
- It solves digestive complaints.
- It increase intra-abdominal pressure benefitting the internal organs especially the liver and kidneys.
- It relaxes both body and mind.

Limitation

- Those suffering from hernia, peptic ulcer, intestinal tuberculosis and acute abdominal pain should avoid this practice.

Makarasana

The Posture is called *Makarasana* as the body resembles the shape of *Makara*, which in Sanskrit means 'crocodile'. *Makarasana* is a relaxing *asana* to body and mind and is very beneficial for reducing stress.

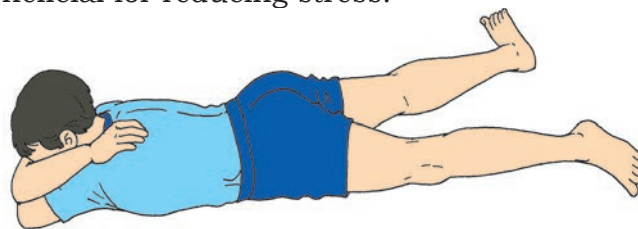

Fig. 8.12: Makarasana



Let us perform *Makarasana* by following the steps given below.

1. Lie down on your stomach.
2. Keep the legs at a comfortable distance with heels inside and toes pointing outward.
3. Fold your arms and elbows, and keep them under the head.
4. Place the head on the cushion of the arms, close your eyes and relax.
5. To come back, bring the arms alongside the body and both the legs together.

Remember the following points

Dos	Don'ts
<ul style="list-style-type: none"> • Both elbows can be kept slightly apart if found difficult to put one above the other. • Do a deeper abdominal breathing. 	<ul style="list-style-type: none"> • Do not press the chest hard on the ground so that the breathing becomes uncomfortable. • Do not bring the feet together.

Benefits

- Traditionally it is a relaxing posture.
- It is beneficial in almost all psychosomatic disorders.
- It is beneficial for respiratory organs, as well as digestive organs.

Limitation

- Those having complaint of obesity and cardiac problems should avoid this practice.

Sarvangasana

Sarvangasana (shoulder stand posture) strengthens the entire body. It regulates the functioning of thyroid glands. It increases the supply of blood to the brain and strengthens the central nervous system enabling the person to fight the problems induced by stress.

Let us perform *Sarvangasana* by following the steps given below.

1. Lie on the back with the hands along the thighs, palms resting on the ground.
2. Pushing down on hands slowly raise both the legs up to 30°. Hold the position for a few seconds.
3. Slowly raise the legs further up to 60° and maintain the position for a few seconds.
4. Raise the legs further up to 90° and maintain the position for a few seconds.
5. Bend the arms at the elbow and place the hands at the hips. Now, cupping the buttocks with hands raise the buttocks. Raise legs, abdomen and chest up vertically

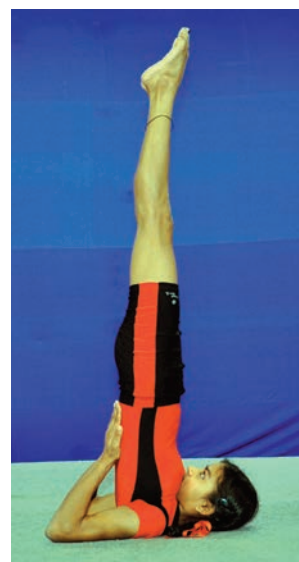

Fig. 8.13: *Sarvangasana*

in a straight line with the trunk. Place the palms on your back to support the back.

6. Push the chest forward so that it presses firmly against the chin. Keep the elbows close to each other.
7. Maintain the position comfortably for 5-10 seconds.
8. To come back, lower the spine very slowly along the floor. Lower the buttocks with hands supporting the back and bring the buttocks on the ground. Bring the legs up to 90° and stop there. place the hands firmly on the ground close to the body. Lower the legs still up to 60° and 30° and then slowly on the ground and relax.

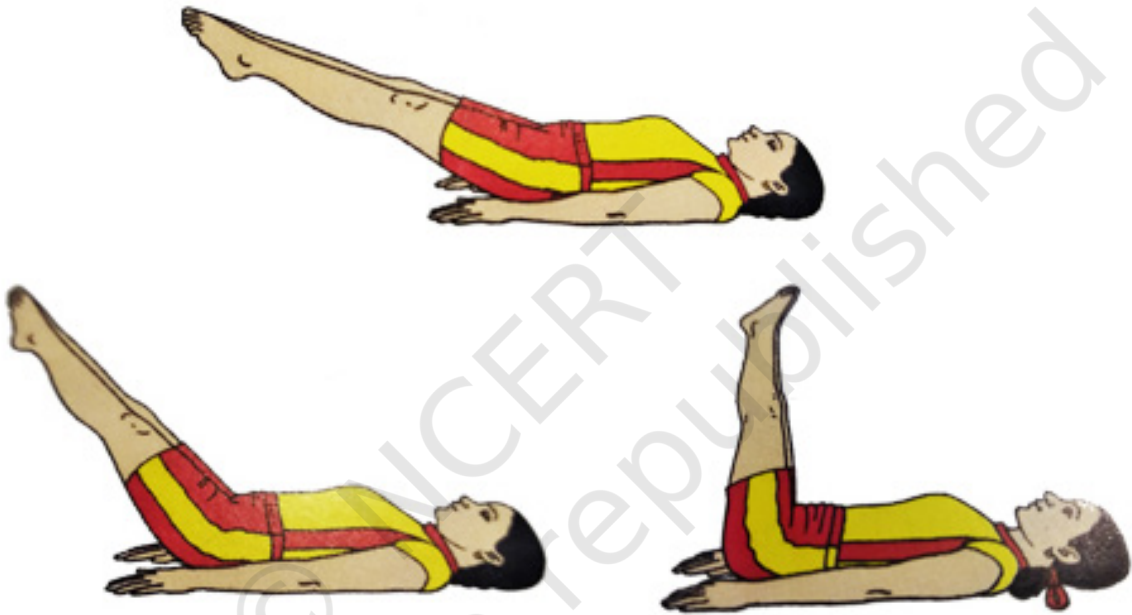

Fig. 8.14: Sarvangasana

Remember the following points

Dos	Don'ts
<ul style="list-style-type: none"> • Movements of the legs should be very slow, stopping at different angles. • In the final position, keep the legs vertical in a straight line with the trunk. • Support the back with your hands. 	<ul style="list-style-type: none"> • Avoid bending the legs. • Avoid jerky action in assuming the final position or returning from it.

Benefits

- It regulates the thyroid function.
- It helps in increasing the circulation of blood to the brain.
- It strengthens the neck region.
- It helps in managing problems related to endocrine glands.



Limitation

- Those suffering from high blood pressure, epilepsy, pain in neck and lumber region, excessive obesity and cardio-vascular complaint should not practise it.

Matsyasana

Matsyasana (fish posture) is effective in reducing stress. In *Matsyasana*, one has a feeling of floating on water like a fish which is soothing to the body and mind both.

Let us perform Matsyasana by following the steps given below.

1. Sit in *Padmasana*.
2. Lie on the back with support of the elbows.
3. Lift the neck and chest slightly up; the back should be arched and raised from the ground.
4. Bend the head backward and place the crown of the head on floor.
5. Make hooks with the index fingers of both hands; and clasp the big toes with hooks of opposite hands.



Fig. 8.15: Matsyasana

6. Maintain the position for 10-15 seconds or as long as comfortable.
7. To come back, release the toes; place hands on the ground; raise head up with the support of hands. Sit with the help of the elbows.

Remember the following points

Dos	Don'ts
<ul style="list-style-type: none">• Try to make the maximum arch of the spine.• Keep the arms bent at the elbows.• The crown of head must touch the floor.• The knees must touch the ground.	<ul style="list-style-type: none">• Do not allow the knees to come up from the ground while arching the back.• While leaning backward, do not strain.

Benefits

- It improves blood supply to the brain.
- It regulates the functioning of thyroid gland and improves immunity system.



- It alleviates backache and cervical spondylitis.
- It diverts the blood from the legs to the pelvic region and helps to increase the tone of the abdominal muscles.
- It is beneficial in lung and respiratory disorders.

Limitation

- Avoid practising this asana in case of vertigo, cardiovascular disease, hernia, arthritis, knee and ankle and spinal problems.

Shavasana

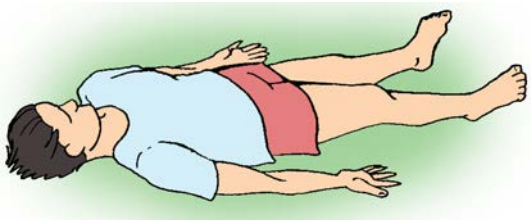

Fig. 8.16: Shavasana

Shavasana (corpse posture) is a relaxing practice. This *asana* is very effective for de-stressing the body and mind which remain in a state of rest. This helps in the repair of tissues and cells, and thereby rejuvenates the body. It helps to reduce blood pressure, anxiety and insomnia and gives relief to the tired body and mind.

Let us perform *Shavasana* by following the steps given below.

1. Lie flat in supine position.
2. Keep the legs straight with feet 8-12 inches apart. Keep the heels inside and the toes outside.
3. Keep the palms facing upward slightly away from the body with fingers in a semi-flexed position.
4. Take a deep breath and simultaneously close the eyes. Feel complete relaxation and try to relax all parts of your body.
5. Breathe normally and concentrate on the flow of breath.
6. To come back, open your eyes and come to the starting position.

Remember the following points

Dos	Don'ts
<ul style="list-style-type: none"> • Withdraw attention from external surroundings. • All parts of the body should be relaxed. • Try to be aware of the internal happenings. 	<ul style="list-style-type: none"> • Do not tense the muscles of body. • Try not to sleep.

150

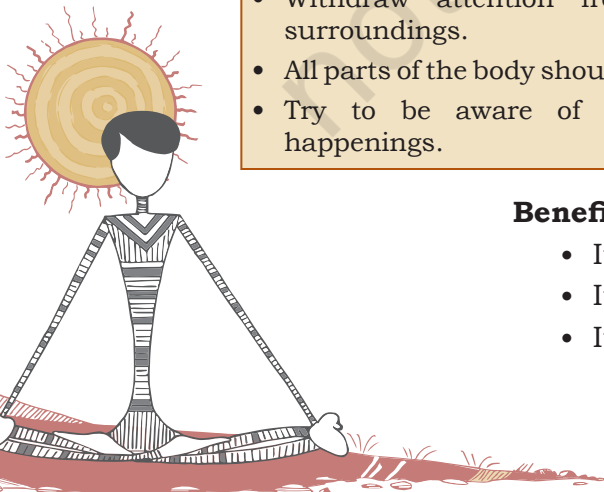

Benefits

- It removes stress and tension.
- It is useful to reduce high blood pressure.
- It relaxes the body and mind.

- It removes fatigue from the body.
- It is beneficial in the case of insomnia as it helps to induce sleep.

Limitation

- Do not practise if suffering from low blood pressure.

KRIYAS

Kapalabhati

Kapalabhati is a kriya (cleansing procedure). It helps to revitalise the nervous system which becomes exhausted due to stress. It invigorates the person and helps in fighting negative effects of stress.

Let us perform *Kapalabhati* by following the steps given below.

1. Sit straight in any meditative pose like *Padmasana* or *Vajrasana*.
2. Take deep breath through the nostrils.
3. Exhale forcefully in such a way that the lower abdomen is contracted to expel out the air. Inhale spontaneously and passively without making any efforts. Do not make effort to inhale. Air will enter the body through the passive inhalation. This is one stroke of *Kapalabhati*. Begin with 20 strokes at a time. This is one round. One can practise one to three rounds in a practical session. Gradually increase the strokes in one round.

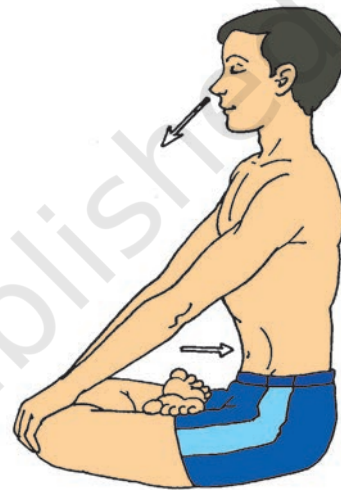

Fig. 8.17: *Kapalabhati*

Remember the following points

Dos	Don'ts
<ul style="list-style-type: none"> • Inhalation should be passive and short, while exhalation should be forceful. • <i>Kapalabhati</i> should be practised after <i>asana</i> but before meditation. 	<ul style="list-style-type: none"> • Do not move the chest or shoulders during exhalation. • Do not contract or distort the face.

Benefits

- It stimulates the nerves in the abdominal region, tones up the abdominal muscles and improves digestion.
- *Kapalabhati* expels more carbon-dioxide and other waste gases from the lungs than the normal breathing.
- It improves heart and lungs capacity and therefore good for bronchial asthma.
- It improves blood circulation throughout the body.
- It energises the body and removes lethargy.

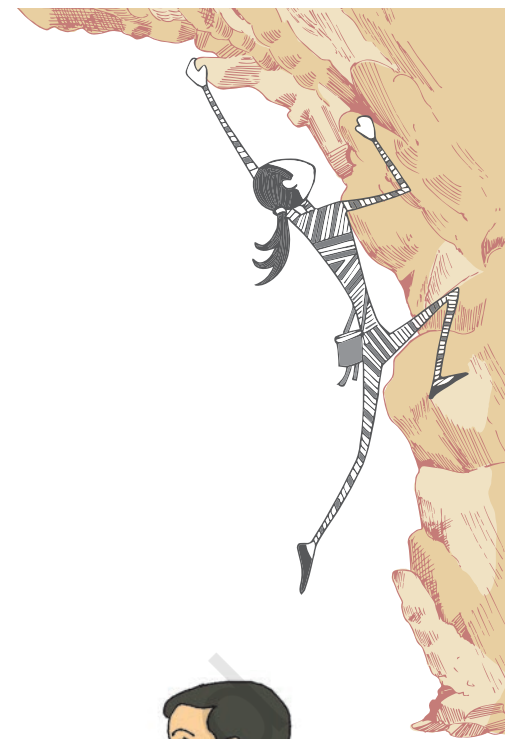

Limitation

- Those suffering from cardio-vascular problems, high blood pressure, hernia, vertigo and gastric ulcer complaints, should avoid practising *Kapalabhati*.

PRANAYAMA**Anuloma-viloma pranayama**

Anuloma-viloma pranayama (Alternate Nostril Breathing) relaxes the body and mind. This pranayama nourishes the body with oxygen, purifies the blood and improves efficiency of the brain. It lowers stress by developing harmony in various systems of the body.

For managing the stress, *anuloma-viloma pranayama* should be practised daily.

Let us perform *anuloma-viloma* by following the steps given below.



Fig. 8.18: *Anuloma-viloma*

1. Sit in the position of *Pashasana* or in any other comfortable meditative posture.
2. Keep the body erect and place the hands on the respective knees.
3. Raise the right hand and place the right thumb on the right nostril and close it.
4. Inhale slowly through the left nostril.
5. Close the left nostril by the ring finger and the little finger and exhale slowly through the right nostril.
6. Again inhale through the right nostril.
7. Close the right nostril with thumb and exhale through the left nostril. This is one round of *Anuloma-viloma*.
8. Repeat it 10 times.

Remember the following points

Dos	Don'ts
<ul style="list-style-type: none"> • Inhale the air slowly without bulging the abdomen. • Keep the ratio of 1:1 or 1:2 between and the exhalation. 	<ul style="list-style-type: none"> • Avoid producing sound from the nose. • Do not press hard on the nostrils. • Avoid retaining breath (<i>kumbhaka</i>) in the beginning.

152

Benefits

- It calms down the mind and improves concentration.
- It improves functioning of all cells of the body by providing them sufficient oxygenated blood.
- It purifies the blood.
- It improves blood supply to brain.
- It helps to regulate blood pressure.
- It helps in managing stress by reducing anxiety.

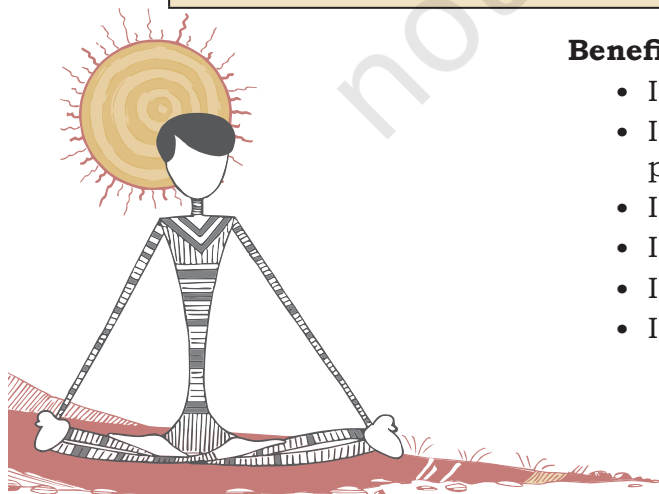

- It is beneficial in many diseases, such as, asthma, high or low blood pressure, insomnia, chronic pain, endocrine imbalances, heart problems, hyperactivity, etc.

Limitation

- In the beginning, retention of breath should be avoided.

Bhastrika Pranayama

Bhastrika pranayama is a yogic breathing practice in which quick and deep inhalation and exhalation are done to strengthen the functioning of lungs. This *pranayama* increases the supply of oxygenated blood to the whole body. It strengthens all the systems of body and provides more energy which is required to fight the effects of stress.

Let us perform Bhastrika Pranayama by following the steps given below.

1. Sit in *Padmasana*, *Ardhapadmasana* or in any other meditative posture. Keep the body erect.
2. Slowly inhale through the nostrils.
3. Then exhale quickly and forcefully through the nostrils.
4. Immediately inhale with force.
5. Continue this forceful rapid exhalation and inhalation counting up to ten breaths.
6. At the end of the tenth breath, the final exhalation is followed by a deep inhalation and slow exhalation. This is one round of *Bhastrika Pranayama*.
7. Take a few normal breaths after this round before starting another round.
8. Complete three rounds of *Bhastrika Pranayama*.

Remember the following points

Dos	Don'ts
<ul style="list-style-type: none"> • Sit straight and open the chest for proper strokes. • Lungs, diaphragm and stomach should move with each inhalation and exhalation. • <i>Bhastrika pranayama</i> should be performed after asana and <i>nadishodhana pranayama</i>. 	<ul style="list-style-type: none"> • Do not go beyond the capacity. • Chest and shoulders should not move. • Do not practice it in extremely hot conditions.

Benefits

- It increases the gastric fire and improves appetite.
- It destroys phlegm.
- It is beneficial in case of asthma.

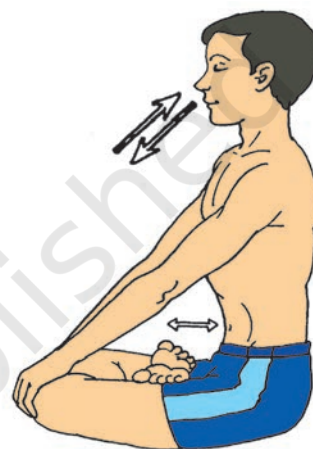
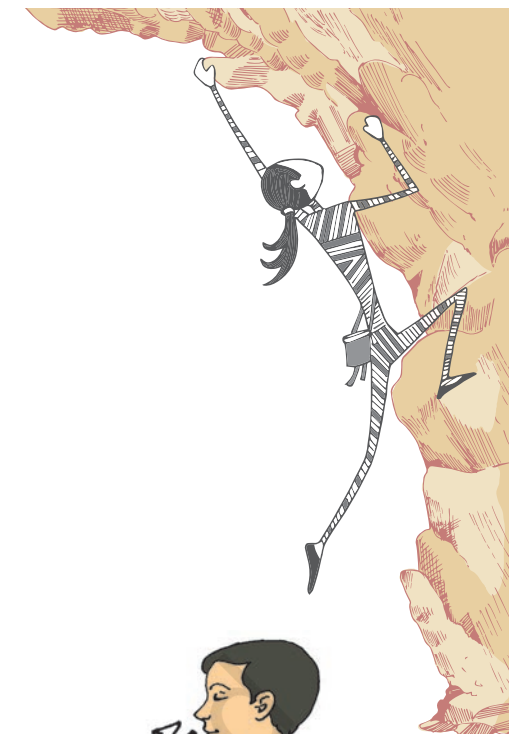

Fig. 8.19: Bhastrika Pranayama



Fig. 8.20: Bhramari Pranayama

Limitation

- *Bhastrika pranayama* should not be practised during ear infection. A person suffering from heart problems, high blood pressure, vertigo, stomach ulcers should not practise this *pranayama*.

Bhramari Pranayama

The word *Bhramari* is derived from *bhramara* which means a 'black humming bee'. In this *pranayama*, the practitioner makes the sound which resembles the buzzing sound of a black bee, therefore it is named as *Bhramari Pranayama*. It is a relaxing *pranayama*. It soothes the mind and, therefore, good for stress management.

Let us perform *Bhramari Pranayama* by following the steps given below.

1. Sit in the position of *Padmasana* or *Siddhasana* or any comfortable sitting position. Close the eyes.
2. Inhale deeply through the nose.
3. Close both the ears with thumbs, put the fingers on forehead and eyes and exhale while making soft sound of a humming bee.
4. Concentrate on the sound keeping it low pitched.
5. After exhalation, bring your hands back on your knees and breathe in slowly. This is one round.
6. Practise five to ten rounds in similar way.

Remember the following points

Dos	Don'ts
<ul style="list-style-type: none"> • While exhaling, make a soft sound like a humming bee. • Focus on the sound and enjoy it. • Practise it after <i>asanas</i> and <i> anuloma-viloma</i>, but before meditation or sleep. 	<ul style="list-style-type: none"> • Do not make the sound at a high pitch.

Benefits

- The sound resonating in the brain is very soothing and removes tension and anxiety.
- It is very useful to reduce high blood pressure.
- It energises the mind and refuels it with new energy.
- It pacifies the mind and helps reduce anger, anxiety and insomnia.
- It helps in enhancing the concentration.
- It improves memory.
- It alleviates throat ailments.

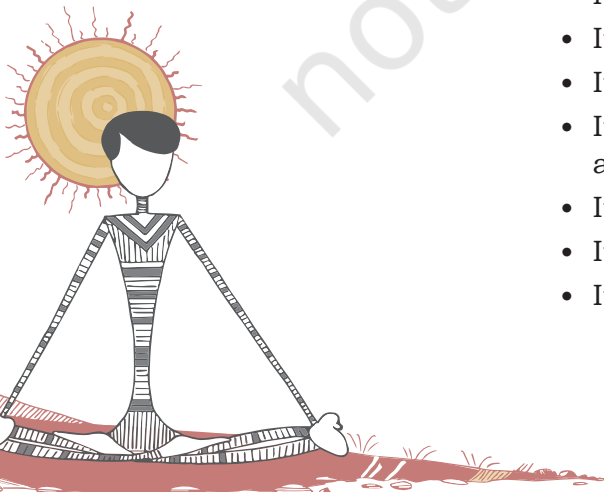

Limitations

- During an ear infection, this *pranayama* should not be practised.
- People suffering from cardiac diseases should also avoid the practice.

Sheetali Pranayama

Sheetali means 'cooling'. *Sheetali pranayama* cools the body and mind, hence the name is *sheetali pranayama*.

Let us perform *sheetali pranayama* by following the steps given below.

1. Sit in *Padmasana* or any other meditative posture.
2. Keep the hands in *jnana mudra*.
3. Open the mouth. Extend the tongue and bring it outside the mouth as far as possible.
4. Roll the tongue from the sides to make it like a tube. The sides of the tongue should be curled up.
5. Inhaling draw the air from the curled tongue and fill the lungs with air to the maximum.
6. Draw the tongue inside and close the mouth.
7. Exhale through the nose.

This is one round of *sheetali pranayama*. Practise it 3-5 times.

Remember the following points

Dos	Don'ts
<ul style="list-style-type: none">• Focus on the tongue and the cooling sensation of the breath.	<ul style="list-style-type: none">• Do not practise it during cold weather.• Do not practice it in polluted environment because inhaling through the mouth does not have filtering process.

Benefits

- It cools the body and tranquilises the mind.
- It quenches thirst and improves digestion.
- It enhances endurance to the deprivation of water.
- It is beneficial in the case of high blood pressure and also in low fever.
- It is beneficial for skin and eyes also.

Limitation

- Persons suffering from low blood pressure, asthma, bronchitis and constipation should avoid practising this *asana*. It should not be practised in cold climate.



Fig. 8.21: Sheetali

Yoganidra

Yoganidra means 'sleep' with awareness. *Yoganidra* is a state of mind between wakefulness and dream. Normally, we sleep without awareness. But in *yoganidra* we sleep with awareness. *Yoganidra* is helpful in management of stress. It relaxes body and mind and reduces tension.

Yoganidra is practised in *Shavasana*. It consists of body and breath awareness. The awareness is rotated in quick succession through all parts of the body, then it is taken to the breath and finally to the mind.

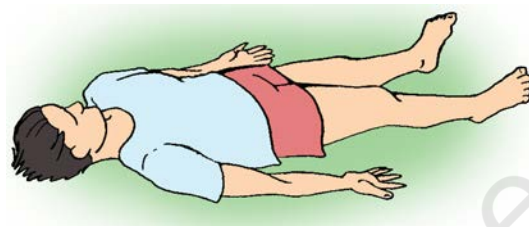

Fig. 8.22: *Shavasana*

Let us practise *Yoganidra* by following the steps given below. Lie supine in *Shavasana*. Take deep breath and feel completely relaxed.

Phase 1: Awareness of the body

Rotate your awareness to different parts of the body as per the instructions give below:

- Relax the first (big), second, third, fourth, fifth toe of the right foot, sole, heel, ankles, calf muscles, knee, thigh and right hip. Similarly relax the first (big), second, third, fourth, fifth toe of the left foot, sole, heel, ankles, calf muscles, knee, thigh and left hip.
- Now relax the thumb of the right hand, first, second or middle, third, fourth (little) fingers of right hand, palm, back of the hand, wrist, forearm, elbow, upper arm and right shoulder. Now relax the thumb of left hand, first, second or middle, third, fourth (little) fingers of left hand, palm, back of the hand, wrist, forearm, elbow, upper arm and left shoulder.
- Now be aware of the back and relax it. Relax the right and left buttocks, middle part of right back, middle part of left back, right shoulder blade, left shoulder blade, the spine and the whole back together.
- Now focus your attention to the front part of your body. Relaxes area above the chest, right and left side of the chest, navel, right and left side of abdomen, upper parts of right and left leg.



- Now relax the left, right, front and back of your neck, throat, chin, lower and upper lip, tip of the nose, the right cheek and left cheek, the right and left ear, the right and left eye, the right and left eyelid, the right and left eyebrow, the space between eyebrows, the forehead, the right, left back, and top of the head.
- Now relax whole body.

Phase 2: Awareness of the breath

- Now focus your attention on breath. Feel the flow of your natural breath. Do not change it. Feel the movement of nostrils with each breath. Now focus your attention on the movements of the abdominal area during breathing. Abdomen falls and rises with each exhalation and inhalation. Continue focussing your attention on breathing and the movement of the abdomen.

Phase 3: Coming back

- To come back, become aware of your body and be aware of the time and place you are in. Move your fingers and toes; and move the head from one side to the other. Take your own time. Be wide awake. Slowly sit up and open your eyes.

Note: After breath awareness a scene may be described and the practitioner is asked to visualise it in that state. Alternately, different things like floating in a swimming pool, sitting in a garden, burning a candle, chirping birds, mountains, flowers, rising sun, a song, etc., can be suggested and the practitioner is asked to develop vision on thinking, feeling and at an emotional level. After this, a resolution also can be made. For making a resolution, before the stage of body awareness, they are asked to think about what they want to pursue. Now the resolution is repeated three times. After this, the person is asked to come back by following the steps as mentioned in the 'come back' phase.

Remember the following points

Dos	Dont's
<ul style="list-style-type: none"> • Relax all parts of body one by one. • Focus on the part of body which is being named. • Follow the instructions properly. 	<ul style="list-style-type: none"> • Do not tense the muscles of body. • Do not sleep.

Benefits

- It reduces anxiety and tension.
- It activates parasympathetic system and thereby helps in management of stress related problems.

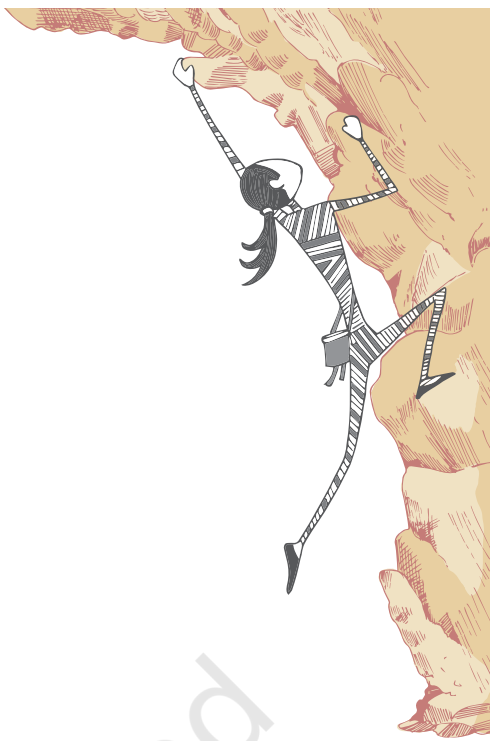



Fig. 8.23: Meditation



Fig. 8.24: Shrishtasana

- It reduces bodily tension and relaxes whole body.
- It helps to reduce blood pressure.

Limitation

- In case of depression this practice should be avoided.

MEDITATION

Meditation is an important yogic practice which is commonly used for relaxation and stress management. Meditation provides rest and peace of mind. During meditation, all kinds of thoughts which are causing stress are eliminated. This results into an enhanced state of physical and emotional well-being. After meditation, the person feels fresh and develops a new perspective on stressful situations. Meditation helps to reduce negative emotions and increases self-awareness.

YOGA FOR HEALTHY LIVING

In this section, some advanced *asanas* are given which you can learn at this stage. These are balancing *asanas* and more difficult as compared to the previously learnt *asanas*. These *asanas* will also help you remain healthy.

Shirshasana

Shirsha, a Sanskrit word means 'head'. In this posture one stands on one's head, hence it is called *Shirshasana* (Head Stand Posture).

Let us perform *Shrishtasana* by following the steps given below.

1. Put a folded cloth or blanket on the floor. Kneel on the ground, with the buttocks resting on the heels.
2. Inter-lock the fingers and form a finger-lock.
3. Place hands on ground making an angle of 60° between the elbows.

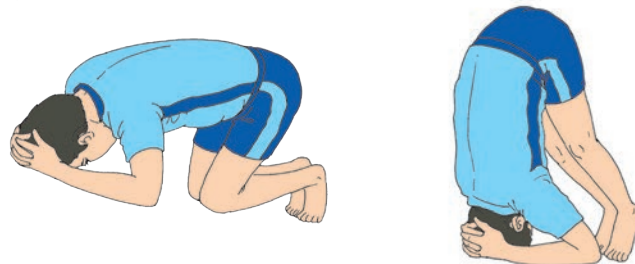
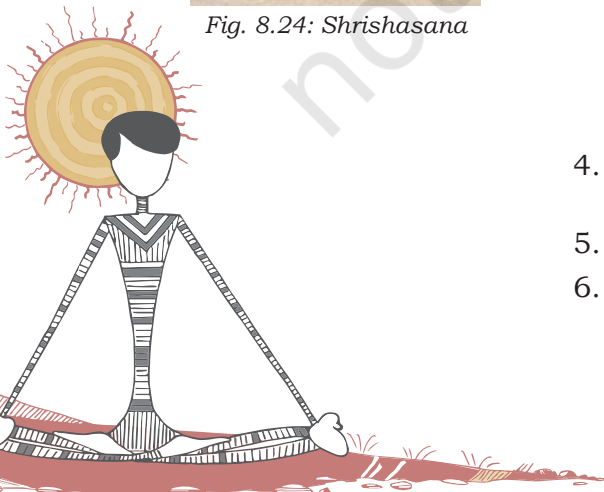

Fig. 8.25: Steps of Shrishtasana

4. Place the centre of the head on the ground supported by the finger-lock.
5. Lifting the knees and the buttocks straighten the legs.
6. Bend the legs at the knees and bring the knees closer to the chest.



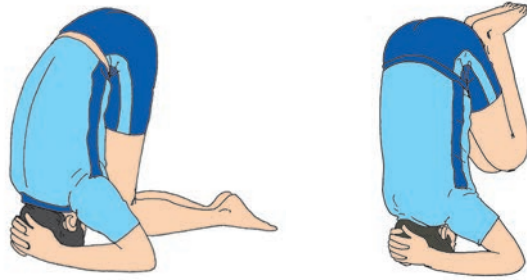

Fig. 8.26: Shrishasana

7. Resting on the elbows and contracting abdominal muscles raise the feet off the ground one by one.
8. Keeping the legs folded in the knees, straighten the thighs.
9. Unfold the legs and bring them vertically in line with the body and maintain the posture for 5-10 seconds.
10. To come back, reverse the order. Fold the legs at the knees.
11. Bring the knees closer to the chest and down to the ground. Take the feet away from the body. Place the knees on the ground. Raise the head and the finger-lock from the ground. Open the finger-lock and come to the starting position.

Remember the following points

Dos	Dont's
<ul style="list-style-type: none"> • All the movements should be very slow. • Proceed from one stage to another after having mastered the former stage. • Keep the elbows firmly on the ground so that the balance is not lost. • Normal breathing should continue. 	<ul style="list-style-type: none"> • Avoid giving any jerk or push to the body to make the balance. • Avoid spreading and shifting the elbows while doing the <i>asana</i> • Avoid any bend in the waist.

Benefits

- It improves blood circulation, particularly of venous blood.
- It helps in the proper functioning of the abdominal organs and endocrine glands.
- It increases the supply of blood to the brain and strengthens the central nervous system.

Limitation

- Avoid performing this posture in case of problems of ears, weak eye, high blood pressure, heart trouble, etc.

Bakasana

Baka, a Sanskrit word, means 'crane'. The final posture in the *asana* imitates a crane, hence, it is called *Bakasana* (Crane Posture).

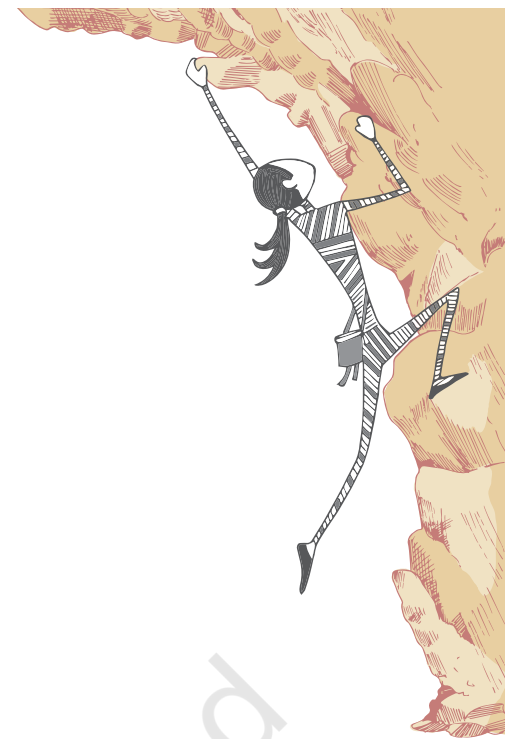

Let us perform *Bakasana* by following the steps given below:

1. Squat on the floor.
2. Place the hands flat on the floor in front of the feet, with the fingers pointing forward. Keep the elbows slightly bent.
3. Pressing the arms, raise the feet with bent knees above the ground. Leaning forward, adjust the knees so that they touch the upper arms near the armpits.
4. Hold the body above the ground while keeping the hands on ground. Maintain the position for 5–10 seconds.
5. To come back, slowly lower the feet to the floor and come to the squatting position.

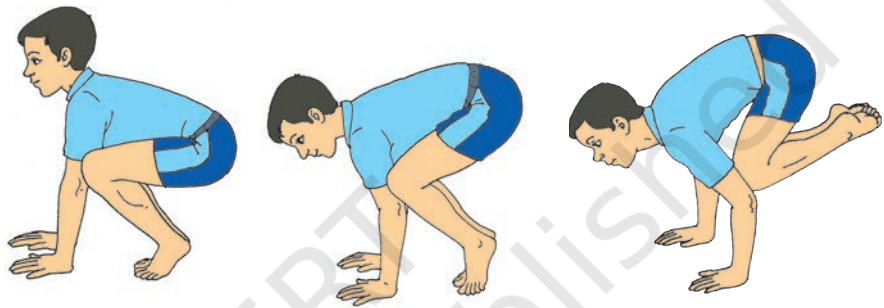

Fig. 8.27: *Bakasana*

Remember the following points

Dos	Don'ts
<ul style="list-style-type: none"> • Spread the fingers. • Keep the chest forward and look in front in the final position. • Contract the abdominal muscles while lifting the body. • Support weight of the body on hands. 	<ul style="list-style-type: none"> • Avoid exerting pressure on the elbow with the raised foot-lock. • Do not make haste in balancing the body.

Benefits

- It increases the strength of the arms and shoulders.
- It increases a sense of balance.
- It tones the abdominal muscles.
- It provides an adequate supply of blood to hand, shoulders and chest.

Limitation

- A person with high blood pressure, heart disease or cerebral thrombosis should not practise this *asana*.

Hamsasana

Hamsa, a Sanskrit word, means 'swan'. In final posture of this *asana*, the body resembles a swan, hence, it is called *Hamsasana* (*swan posture*).

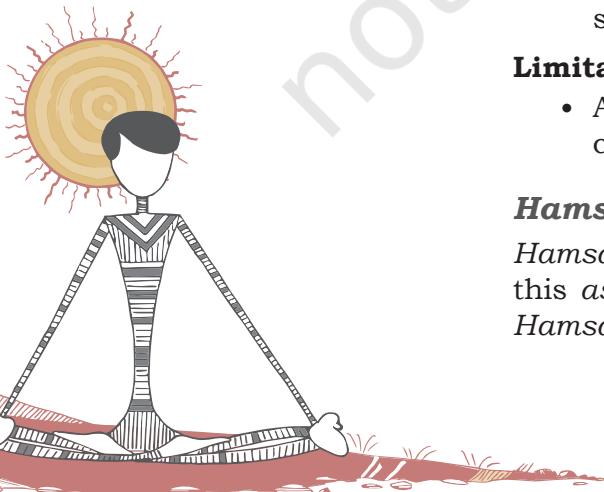

It is a preparatory pose for *Mayurasana*. The only difference is that in *Mayurasana* legs are raised; while in *Hamsasana* feet are kept on the ground and the body is kept little bent and balanced on the elbows.

Let us perform *Hamsasana* by following the steps given below.

1. Take the kneeling position.
2. Keep a little distance between the knees, keeping the heels together.
3. Place the hands in front between the knees on the ground, fingers pointing towards the feet.
4. Place the elbows on the naval region.
5. Extend the legs. Raise the trunk up, keeping the feet together. Place the tip of toes on the ground. Rest the whole body on the elbows pressing the abdomen. Maintain this position for 5-10 seconds.
6. To come back, bend the legs and bring them closer keeping the knees on the ground. Remove the elbow from the abdomen. Bring the hands to the sides of the body and the knees closer and come to the starting position.

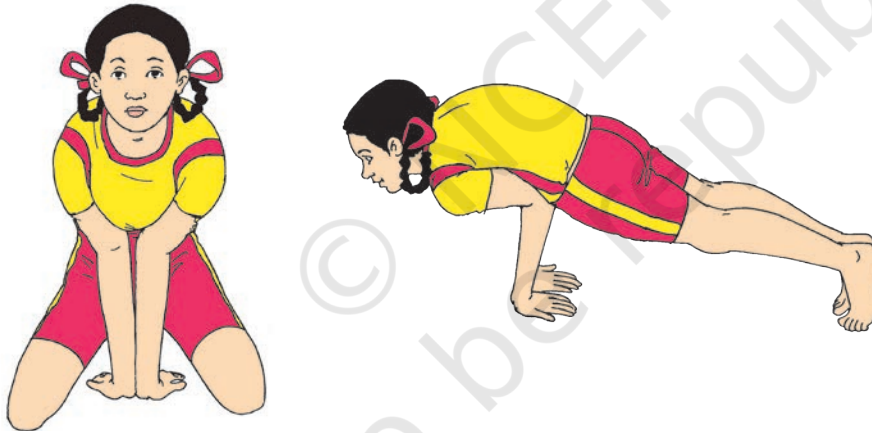

Fig. 8.28: *Mayurasana*

Remember the following points

Dos	Dont's
<ul style="list-style-type: none"> • Keep the legs straight. • Keep the elbows together. • Keep the fingers spread out. • Tense the muscles of the body when raising the trunk. 	<ul style="list-style-type: none"> • Avoid keeping more distance between the bent elbows kept on the abdomen. • Do not jerk the body.

Benefits

- It gives exercise to the arms.
- Pressure exerted on the abdomen in this *asana* improves functioning of the kidneys and liver.

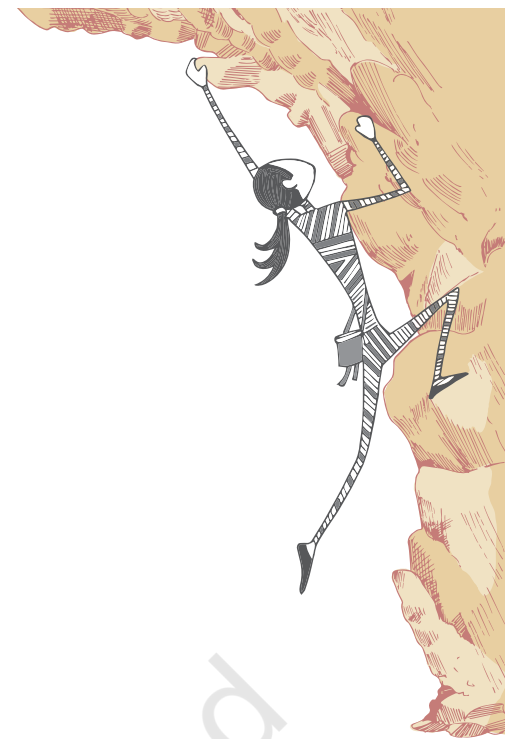

- It increases appetite.
- It helps to develop control on muscles and balance in body.
- It massages the digestive organs and alleviates problems of constipation and dysentery.

Limitation

- A person suffering from peptic ulcers, hyper acidity, high blood pressure or hernia, should not practise this *asana*.

Mayurasana

In Sanskrit *Mayura* means 'peacock'. In the final posture, the body resembles a peacock, hence, it is called *Mayurasana* (peacock posture).

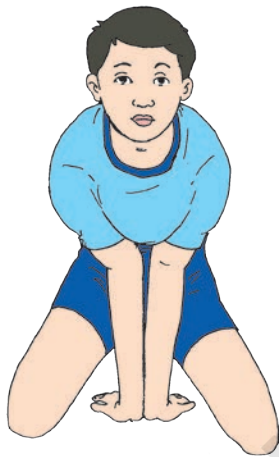
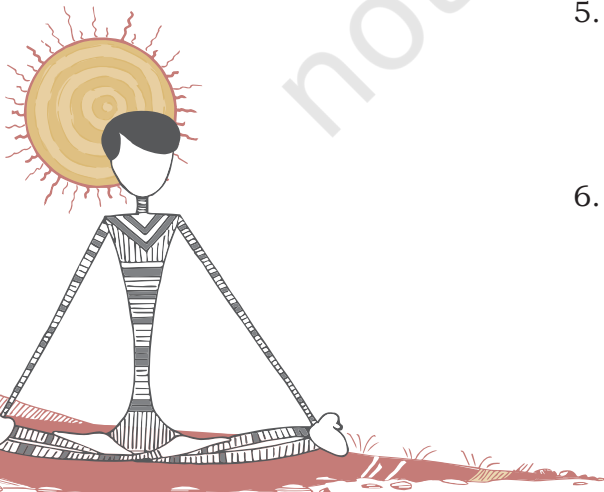

Fig. 8.29: Mayurasana

Let us perform *Mayurasana* by following the steps given below.

1. Kneel on the ground.
2. Keep both feet together and knees apart.
3. Bring the elbows together and place palms on the ground between the knees, the fingers facing towards the feet.
4. Place the elbows at the navel region and stretch the legs backwards.
5. Slowly raise the trunk and legs off the ground. Maintain this position for 5-10 seconds. The whole body should be balanced on palms and supported by abdominal muscles by shifting the body weight a little forward and balancing the body on the elbows.
6. To come back, lower the legs to the ground. Bring the legs towards the hands and place the knees on the ground. Remove elbows from the navel and place the hands by the side of the body. Reduce the distance between the knees and come to *vajrasana*.



Remember the following points

Dos	Don'ts
<ul style="list-style-type: none">• Shift the body weight by propelling the body forward and raising the legs up while balancing the body.• Spread out the fingers well to secure a broad base for balance.• Tense the muscles of the body while raising the trunk.• In the final position, the weight of body should be supported by abdominal muscles.	<ul style="list-style-type: none">• Do not throw the legs up with a jerk.• Do not keep the elbows apart while in balance.

Benefits

- It strengthens the arms.
- It helps to promote circulation in the abdominal region.
- It helps to increase appetite.
- It massages the digestive organs.
- It helps to regulate the functions of kidneys and liver.
- It helps to develop muscle control and balance in the body.

Limitation

- A person suffering from high blood pressure, heart disease, hernia or peptic ulcers should not practise this *asana*.

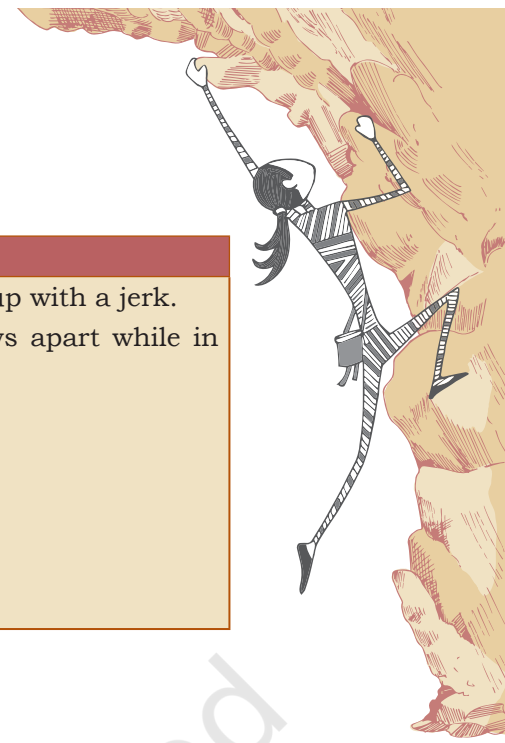

ASSESSMENT

I. Answer the following Questions

1. 'Yoga is a way of life'. What makes it a way of life?
2. Which specific Yoga practices are relevant for relaxation?
3. Mention any two stressful situations experienced by you.
4. List any two positive and two negative effects of stress on body.
5. Write any two symptoms of stress

Physiological symptoms	Emotional symptoms	Behavioral symptoms
•	•	•
•	•	•

6. You are stressed due to a certain happening. Mention any two yogic practices you would like to perform to de-stress yourself. Give reasons.
7. Write the advantages of the following yogic practices:
 1. *Shirshasana*
 2. *Anuloma- Viloma Pranayama*

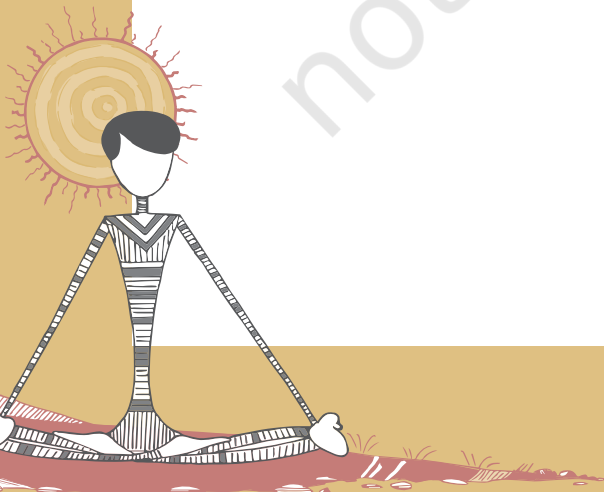



DIETARY CONSIDERATIONS AND FOOD QUALITY



Food is a basic human need. It is consumed to provide nourishment to the body. To achieve optimal level of fitness certain dietary considerations are required. Mostly food is consumed for its taste or appearance; however, both nutritive value and quality of food need attention. Food quality, food adulteration, food spoilage and impact of indiscriminate use of pesticide and radiation on human health have been discussed in this lesson.



1077CH09

DIETARY PLANNING

Dietary planning is an important step in proper food selection and preparation of meal to stay healthy and fit. Dietary planning is a process of developing meal plans for adequate nutrition within the available resources. Nutritional requirement and food choices vary with regard to their age, sex, activity level and physiological condition. Food is planned accordingly to make it enjoyable, satisfying and healthy. Planning is a scientific method of saving energy, time and money. It makes the tasks of procuring raw material, preparing meals and ensuring food quality simpler. It adds variety the meals and reduces wastage.

You have studied the five food groups in Class IX. Revise these and for reference keep these handy.

Activity 9.1

- Plan a meal (lunch or dinner) including some food from each food group.
- Record your one day diet. Analyse each food preparation according to the food group. How could you improve your diet for the missing nutrients?

FACTORS AFFECTING THE PLANNING

Everybody needs a balanced diet irrespective of age but certain factors influence the food choices. Consider the following factors while planning meal for good health and fitness.

Age

Body's need for food and nutrients varies greatly with age. An infant needs only mother's milk initially but needs extra

food and nutrients with growing age. Adolescents grow at a fast pace and are active, so they need extra nourishment. But their food preferences are often influenced by friends and media rather than nutritional requirement. They need guidance in this regard. Nutritious food preparations can be planned in the form they enjoy, like spinach paratha or spinach, carrot and potato soup instead of spinach vegetable. Elders often have difficulty in chewing, swallowing and digestion; they need soft and easily digestible foods, such as, well cooked vegetables, idli etc.

Gender

Nutritional requirements vary with gender. Till the age of 10 years nutritional requirements are same, thereafter both grow at different pace and their body composition is also different. Mostly men are taller and heavier than women. They are more muscular while women have more fat cells. Thus, their body types are different leading to different nutrient requirements. Females need more iron (hemoglobin) due to blood loss during menstruation. Lack of iron often puts them at high risk of iron deficiency or anemia. Whole grains, seasonal fruits, green leafy vegetables and dairy products are healthy for both genders. Food preferences may also vary with gender.

Physical activity

Energy and nutrient requirements vary with physical activity. Sitting jobs like reading, computer work, etc., need less energy and heavy duty tasks like cycling, carrying heavy load, sports, etc., need more energy. Intensity and duration of activity also affect the requirements, e.g., a person cycling normally needs lesser energy than a person participating in a race, need nutrients, like vitamin B, in accordance with energy requirement. In general energy from fried foods, extra butter or ghee needs to be avoided. Food preparations from whole foods, nuts, oilseeds, dairy foods, egg, and fish can fulfill the requirement for energy and other nutrients.

Physiological state

Physiological conditions like infancy, childhood, adolescence, pregnancy, lactation impose high demands of food and nutrients due to higher rate of growth and development. For example, a healthy sedentary woman needs 1900 kcal/day while the same woman, if pregnant, will need 2200 kcal. Similarly an adult man needs 0.8 g protein/Kg body weight/day. The same person if an athlete requires 2.0g protein/Kg body weight/day. Foods like *laddoo* (rich in calories) are quite suitable for highly active and growing persons while those with sedentary life style should avoid them to prevent becoming overweight. Careful selection is

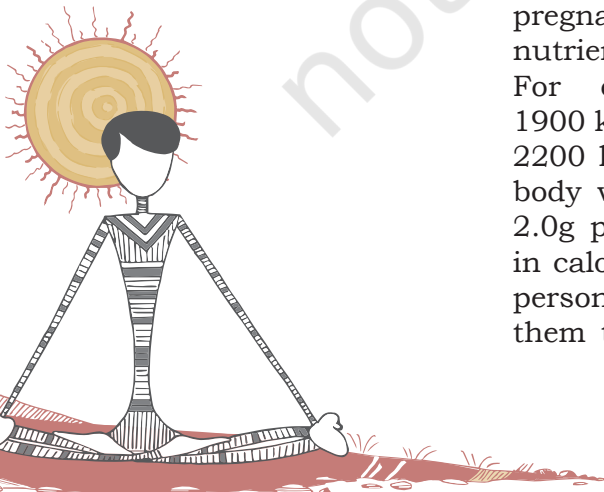

helpful to prevent malnutrition and illnesses. Physiological state also affects the food preferences.

Economic considerations

Some foods are expensive while others are cheap but both may provide similar nutritional benefits, e.g., cashew nuts are expensive, groundnuts are cheap and both are good sources of fat, protein, vitamins and minerals. Seasonal, local, fresh foods are cheaper and more nutritious. The cost of a food item also varies from one place to another. Purchasing from whole sale markets, haats, etc., is economical. Homemade food is cheaper.

Time and skill

The number and types of dishes served in a meal depend on the availability of time, ingredients, equipment and skills of the person who cooks. Lack of these may influence the quality of the meal. Hence, it is necessary to plan in such a way that nutritional quality is maintained. Preplanning and time management skills are useful in preparing nutritious meal in lesser time. All members of the family, including children, need to be engaged in food preparation activities in an appropriate manner.

Region, religion and culture

Eating habits are often linked with the foods produced in the locality, e.g., people living in coastal areas eat more fish or coconut is popular in Kerala. When the same food is consumed over a period of time it becomes cultural practice. Religion also influences the food habits e.g., the Jain community does not eat onion, garlic, eggs, fish, meat, etc., However, mobility, technology and various modern factors are lessening such impacts. Certain foods are associated with festivals like, *gujia* in Holi.

Food preferences of individuals

Food preferences vary from person to person and strongly affect planning of meals, e.g., a vegetarian cannot eat meat and a non-vegetarian will not get satisfaction with only vegetarian dishes. People from south India will get satisfaction with idli sambhar instead of dal roti. Occasional change is accepted but dissatisfaction resulted from less preferred food over a long period of time may lead to under-eating, malnutrition and health problems.

Sensory appeal

How food satisfies the sensory organs, e.g., tongue, nose, eyes, ear, constitute sensory appeal. Good looking and aromatic food appeals and attracts everybody. Appearance,

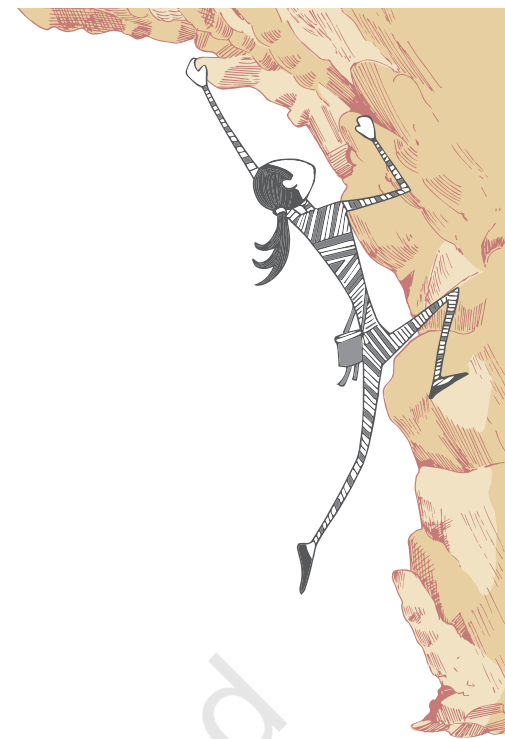

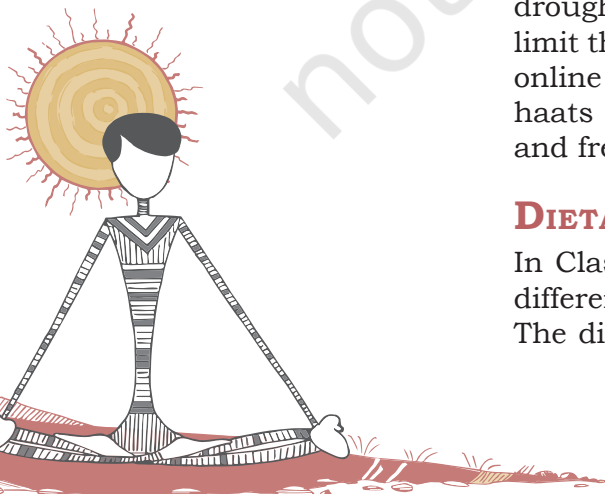

Fig. 9.1: Taste

Activity 9.2

- Ramesh plans to make chapatti, dal, spinach vegetable, raita and a sweet for himself and his wife; while Mahima consumes missi roti, mint chutney and buttermilk as she has to go to work as a labor in an industry. Compare and evaluate their meals.
- Name five food items you started eating after seeing the advertisements. Explain good and bad features about each of them. What feature in the advertisement attracted you the most?

168



taste, flavor, texture, temperature, also play a crucial role in food acceptance. For example, *papad* has to be crisp and bread soft; ice cream chilled and soup hot. This has to be given due consideration.

Related concepts

Taste is a sensation perceived in the mouth and throat. There are four tastes, i.e., sweet, salt, bitter, sour. The fifth taste is referred to as umami which is similar to the taste of monosodium glutamate (MSG).

Ayurveda describes six tastes namely, sweet, salt, bitter, sour, pungent and astringent which can easily be linked with the tastes of sugar, salt, neem, lemon, chilli and amla respectively.

Flavour is sensed by both nose and tongue together. It includes both aroma and taste. Lemon has lemony flavor and sour taste. Specific compounds when present in a certain food give them distinct flavor and can also be modified by processing.

Satiety value

Satiety value implies a sense of pleasure and satisfaction that a person gets from eating food. While planning meals, it is important to take care that it keeps one satisfied for sufficient time and does not lead to hunger pangs soon. This in turn will affect the working capacity, efficiency and health of a person.

Media and advertisement

Many persons, particularly children, choose food tempted by advertisements. Further they choose a certain food because it is available on discount or as a free gift. Such practice is common with some processed, packaged and ready to eat foods. These items may initially attract, appear cheap but on regular use they may turn out to be costly, less nutritious and unhealthy. Hence it is necessary to see nutrition facts on the label of the packing to make healthy food choices. Using the same concept to advertise nutritious foods will encourage people to choose and consume healthy diets.

Accessibility and transport

Foods available nearby are usually selected. It commonly happens with people living in remote areas, elders, handicaps and persons not having requisite transport facilities. Famines, droughts, heavy rainfall, cyclones and road blockages further limit the food supply. Big *bazaars*, home delivery system and online purchase have improved the access to food. Local haats are organised which are also good sources of cheap and fresh food items.

DIETARY CONSIDERATIONS FOR SPORTSPERSONS

In Class IX you have studied the dietary considerations for different life stages of humans for their health and wellbeing. The diets of sportpersons should be managed to help them

exhibit their best performance and maintain endurance. They are constantly indulged in intense physical exercises, training, matches and competitions and other sports-related activities. Hence their energy and nutritional requirements are also very high. Besides age, gender, body composition, types of sports, intensity and duration of the event, the environmental factors also greatly affect their nutritional requirements. Adequate nutrition is of utmost importance for their health, physical fitness, endurance, peak performance and prevention of dehydration, injury and infection. The right kind of food given at the right time in right proportion is of paramount importance for sportpersons to prolong their sporting life.

Carbohydrates

Carbohydrates are major sources of energy for sportpersons. For general fitness, 3-5 g carbohydrate per Kg body weight per day is sufficient. For intensive sport like football, gymnastic, weight lifting, 5-10 g carbohydrate per Kg body weight per day may be required. Body stores of carbohydrate (glycogen) must be sufficient before and during exercise. Glycogen stores determine the stamina and performance. For one hour of exercise, no extra intake except water is needed. Carbohydrate requirement increases with increasing duration of workout. Timing of carbohydrates intake is vital. Intake of high carbohydrate, easily digestible food, 2-4 hours before training and event are advisable for quick energy release and replenishment in the body. Food preparations having potato (baked), bread, rice, semolina (suji), and banana along with liquid food are suggested. Excessive consumption of carbohydrates may lead to weight gain, cause digestive discomfort, muscle stiffness, diarrhea, lethargy, etc., and eventually hamper the performance.

Protein

Depending upon the intensity of the sport, protein requirement can range from 1.2 -2.0g per kg body weight per day. Sufficient intake of carbohydrates ensures that protein is used for building and repairing of muscles and tissues; for formation of hormones, enzymes, antibodies and neurotransmitters; preventing damage; and not for giving energy. For better utilisation of protein, consume carbohydrate and protein food sources in appropriate proportion, preferably 3:1 or 4:1 for better performance in endurance events.

Foods like egg, whey protein, soy and milk (casein), low fat dairy products, grains, nuts, seeds and beans provide good quality protein. Readymade protein powders should be avoided or taken under expert supervision only. Low protein intake makes sportpersons susceptible to fatigue,

Activity 9.3

- Make a diet plan for your team participating in football in Meghalaya, giving suitable justifications.
- Your physical education teacher must be planning events for sports day. Note down the diets he or she suggests to you. Relate all in terms of food groups and give your suggestions in terms of suitability to the game you are playing.



lethargy, muscle weakness, injuries and infection. At the same time high protein intake particularly from animal foods or protein powders or supplements may cause unnecessary weight gain, calcium excretion in urine and adverse effect on bones, liver and kidney functions. Consumption of more protein is advisable after the event, during rest period for repair and recovery of the body.

Fat

Fat is not considered a good source of energy during exercise and competition. It is metabolised very slowly, thus, is better for slow and long duration events like marathon. Fats like butter, cream, cow's ghee or coconut oil are good for synthesis of hormone necessary to maintain stamina in sport. Nuts, seeds, low fat dairy products are good choices as they also provide other nutrients and antioxidants. Foods rich in omega-3 fatty acids like flax seeds, fish oil, salmon, consumed in the right amount, enhance strength and vigour in the body and accelerate performance. However, high intake of fat eventually leads to overweight, obesity and associated health problems which hamper performance significantly.

Vitamins and minerals

Vitamins and minerals are crucial in sport because energy utilisation in the body is largely associated with them, particularly some group B vitamins and magnesium. Folate, calcium, zinc, iron are other crucial micronutrients which get depleted faster during long exercises. Vitamin C plays an important role in collagen synthesis and absorption and utilisation of iron in the body. Vitamin B6 helps in protein utilisation. Vitamin A, E and C are important to prevent cell damage and act as antioxidants which are needed to reduce stress and improve stamina and immunity. Adequate intake of these supports the performance and recovery from injury in sport. Colorful fruits and vegetables, dairy products, seeds, nuts and whole grains taken in sufficient amount can provide the needed vitamins and minerals.

Water and fluids

Water and fluids maintain the hydration level and electrolyte balance in the body and are crucial in sports. Dehydration can be serious and can lead to heat exhaustion, profuse sweating, muscle cramps, vertigo (fainting), vomiting, constipation, excessive fatigue and disturbance in vision and coordination. It can hamper the performance and reduce endurance significantly. Drinking 2-2.5 liters of water may be adequate but up to 5-6 liters a day in hot weather and intense exercises may be needed. Sometimes just potable water is not sufficient addition of glucose and salt is also needed.

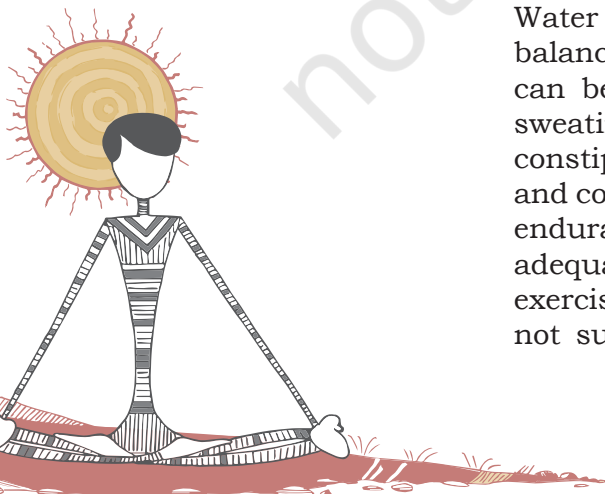

Cool but not cold water is better absorbed and maintains the body temperature. Safe drinking water and beverages like coconut water, fruit juices, thin shakes and sugarcane juice are good choices to maintain energy and hydration levels. Recommendations are available for required amounts of water and fluid intake before, during and just after the event.

Sports Authority of India along with some other reputed institutions has suggested the nutritional guidelines for different sport. Find out about them.

FOOD QUALITY

Nutritious food too, if contaminated or adulterated is not safe for consumption as it may cause infection or disease. Hence the causes of food spoilage, and the ways to improve the food quality need to be understood.

Food quality is the criteria by which a person accepts or rejects any food item. It is crucial at every stage of food handling from farm to table. Good quality food brings health and well-being and poor quality can cause illness and rejection of food in the market as well. Quality of food is often judged in terms of microbiological load and alterations in physical parameters and chemical composition of food. Food quality risks include food adulteration. In order to protect the health of the people every government enforces certain laws and regulations. In India it is the responsibility of Food Safety and Standards Authority of India (FSSAI) to ensure safety and quality food.

Food Safety and Standards Authority of India (FSSAI) is a statutory body under Food Safety and Standards Act 2006. It now encompasses previously employed eight acts in the interest of food operators and consumers. It ensures the availability of wholesome food that is safe for consumption. Amendment and up-gradation are done from time to time. FSSAI code is given to each food item which you can see on various food products.

Physical examination of food is done on the basis of size, shape, color, texture and visual appeal. The food should be free from dirt, cracks or any foreign material; contamination by bacteria, mould, virus, yeast; and infestation by insects, pests, rats, mice, flies and cockroaches which lead to food spoilage and make the food unfit for human consumption. Food quality can seriously be influenced by factors like heat (temperature); air (oxygen, humidity) or moisture content of food, type of food itself and its composition, treatment given to food during processing, handling and storage. Food quality is favorably altered by techniques of food preservation. It is also possible to enhance nutritional quality of food by fortification.



Fig. 9.2: FSSAI



Fig. 9.3: Fortified



Fig. 9.4: Agmark of India

Activity 9.4

- Visit to nearby market, select any 10 food items and report food quality based on the check points above.
- Collect 10 packaged foods and record five points reflecting the food quality in each.
- If you have found low quality food then what you would do?



Fig. 9.5: ISI

Activity 9.5

- Collect five perishable food items and leave them at room temperature. Also store the same five food items in the refrigerator. Record the changes in food items kept in both places and assess them in terms of food quality.
- Write five semi-perishable and five non-perishable food items you regularly use in your diet.
- Government of India has developed five booklets on food safety. Search on the portal (www.snfportal.in) and record 10 points to prevent food spoilage which can be followed in day-to-day life.

It is necessary to observe the quality marks, like FSSAI, AGMARK and ISI, on the food articles while selection to ensure quality.

When food quality is modified intentionally, it is called food adulteration. Over ripening or excessive microbial load causes food spoilage. All these aspects are discussed briefly in the following section.

Check points to ensure food quality

- Check for cuts, bruises, foul smell, discoloration and wrinkles on fruits and vegetables before purchase, handling and consumption.
- Check for any foreign material or adulterant in food.
- Check for seal of the packet or lid of the container or bulging of container.
- Read label for safety, permitted color, preservatives, ingredients, specific information, direction of use, FSSAI code, manufacturing and expiry or “best before” date.
- Avoid buying loose food items particularly flours, oil, spice powders, etc.
- Be watchful for harmful chemicals and colors used to give product a certain look, e.g., acid washed ginger and colored sweets.

Food spoilage

Food spoilage indicates that the food is unfit for human consumption. It is a serious threat to food quality and can be fatal. It is mainly caused by microorganisms, over activity of some enzymes and insects, pests and rodents. High moisture content, temperature and nutrient composition of food affects the growth of causative factors and accelerate food spoilage. The knowledge of approximate shelf life of different foods helps in reducing spoilage. The duration of time during which the food item remains fit for consumption at room temperature is called shelf life which determines perishability. Thus, foods are —

1. **Perishable** which remain fresh and edible for few hours to 1-2 days only, e.g., milk, meat, green leafy vegetables.
2. **Semi-perishable** which remain fresh and edible for about a week (5-7 days) e.g., some vegetables and fruits.
3. **Non-perishable** which remain fresh and edible for more than a month, e.g., grains, sugar, oil, pulses.

Food is precious and is not available in unlimited quantity. So food should not be wasted rather protected from spoilage. Proper storage of food decreases food spoilage and various



treatments can also be given for this, food preservation is one of them.

Food preservation

Food preservation is the process of treating and handling food to stop or slow down spoilage and extend shelf life of food. It works on the principles of reducing the moisture content, preventing the growth of micro organisms causing spoilage and controlling enzymatic activity. The techniques are —

1. **Heat treatment:** Application of heat helps in preserving food by destroying the harmful microorganisms. For example, Pasteurisation of milk and sterilisation of bottles.
2. **Refrigeration and freezing:** Low temperature limit the enzymatic and microbial activities keeping the food safe for longer duration.
3. **Drying or dehydration:** This technique is based on reducing or removing the moisture content of food as microbes cannot grow in the absence of water.
4. **Addition of preservatives:** Preservatives are natural or chemical ingredients which selectively control the growth of microorganisms and enzymes in food and restrict spoilage. Jams and jellies are preserved by sugar and pickles by salt, spices and oil. Acid medium also restrict the growth of bacteria. Chemical preservatives like sodium benzoate or Potassium Meta bisulphite (KMS) are used in ketchups and squashes. Preservatives are used in very small quantity. Use above the prescribed limit is harmful and punishable under law.
5. **Preservation by Radiation:** Radiations are emissions of intense energy capable of penetrating tissues. When food is exposed to specific form of radiation (gamma rays from Cobalt 60) under controlled conditions it increases their shelf life and is referred as irradiated food. Items like fruits, potatoes, onions, spices, herbs and some ready-to-eat foods can be preserved in this way. But this technique is not suitable for milk and milk products. The safety of irradiated foods is under debate. Consumers can choose or avoid irradiated foods by identifying its symbol on the label. This mark has been approved by Food safety and Standards Regulations Authority of India (2015).

Food adulteration

Food adulteration is an unhealthy and illegal practice of adding the low grade ingredient(s) in the original food or

Activity 9.6

- Choose three preserved foods prepared at your home and another three from the market. Identify the method of food preservation in each and the preservative used, if any. Classify the preservative as natural or chemical.
- Identify one preservative for each: lemon pickle, guava jelly, frozen peas, pineapple squash and bread.

173

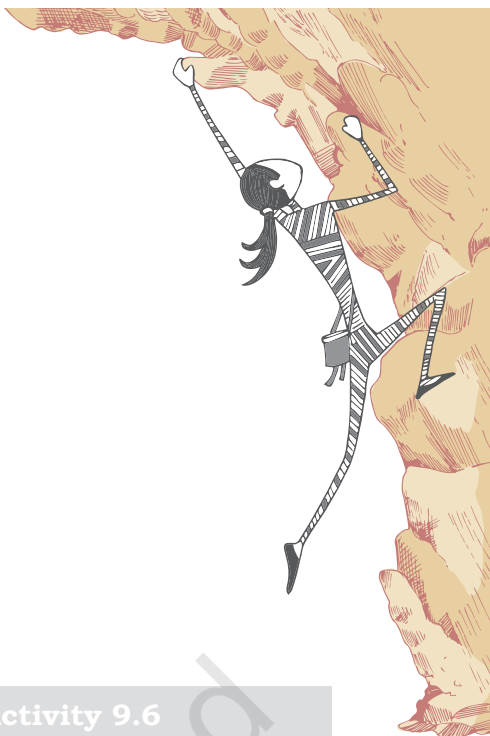

deleting the vital component. It is usually done intentionally to increase the profits. It makes the food unsafe to eat; degrades the food quality and is injurious to health.

Under Food Safety Standards Act (2006) adulterated food is now termed as substandard food, unsafe food or food containing extraneous matter. The helpline where an individual can lodge complaint is —

<http://nationalconsumerhelpline.in/foodSafety.aspx>

The following criteria designate any food as adulterated or unsafe and the person responsible for any of these is punishable under law —

1. The article itself, or its package thereof, is composed, whether wholly or in part, of poisonous or deleterious substances.
2. The article consists of, wholly or in part, any filthy, putrid, rotten, decomposed or diseased animal substance or vegetable substance.
3. The article contains of unhygienic processing or the presence of any harmful substance in that article.
4. It contains substitution of any inferior or cheaper substance whether wholly or in part.
5. It contains addition of a substance directly or as an ingredient which is not permitted.
6. There is abstraction, wholly or in part, of any of its constituents.
7. The article is colored, flavored or coated, powdered or polished, so as to damage or conceal the article or to make it appear better or of greater value than it really is.
8. There is presence of any coloring matter or preservatives other than that specified in respect thereof or in quantity more than prescribed.
9. The article has been infected or infested with worms, weevils, or insects.
9. The article is prepared, packed or kept under insanitary conditions.
11. The article is misbranded or sub-standard or food containing extraneous matter.
12. The article contain pesticides and other contaminants in excess of quantities specified by regulations.

The following tests for common adulterants can be performed by students themselves (Table 9.1).



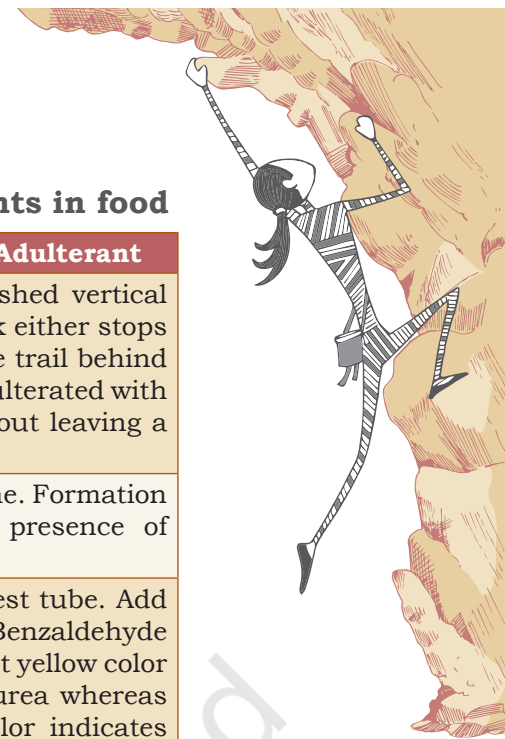

Table 9.1 Methods for detection of common adulterants in food

Food Product	Adulterant	Method for detecting the Adulterant
Milk	Water	Put a drop of milk on a polished vertical surface. The drop of pure milk either stops or flows slowly leaving a white trail behind it. On the other hand, milk adulterated with water flows immediately without leaving a mark.
Milk	Starch	Add 2-3 drops of tincture iodine. Formation of blue color indicates the presence of starch.
	Urea	Take 5 ml milk sample in a test tube. Add 5 ml Para-dimethyl Amino Benzaldehyde reagent. Appearance of distinct yellow color indicates presence of added urea whereas formation of slight yellow color indicates natural urea in milk.
Mustard Seeds	Argemone Seeds	Argemone seeds have rough surface and are tinier in size and black in color. Mustard seeds on pressing are yellow inside, while argemone seeds are white.
Sugar	Chalk	Dissolve sugar in a glass of water, chalk will settle down at the bottom.
Silver Foil	Aluminium Foil	On ignition genuine silver foil burns away completely leaving glistening white spherical ball of the same mass while aluminum foil is reduced to ashes of black grey color.
Honey	Sugar solution	A cotton wick dipped in pure honey burns when ignited with a match stick. If adulterated, presence of water will not allow the honey to burn and if it does, it will produce a crackling sound.
Coffee	Chicory	Gently sprinkle the coffee powder on the surface of water in a glass. The coffee floats over the water but chicory begins to sink within a few seconds.
Tea	Coloured Leaves	Pour water drop by drop at the heap of the tea leaves placed on a filter paper. Water will dissolve the added colour and leave streak of colour.
	Iron filings	Move a magnet through the sample. Iron will stick to the magnet.
Red Chilli Powder	Rodamine	Take 2 gms sample in a test tube, add 5 ml of acetone. Immediate appearance of red color indicates presence of Rodamine.
	Saw dust	Add the sample to water. The saw dust will float at the surface of water while chilli powder will settle down in bottom.

Turmeric Powder	Artificial colour	Natural turmeric powder leaves a light yellow colour while settling down whereas adulterated turmeric powder will leave a strong yellow colour in water.
Dal — arhar, huskless moong and channa	Metanil Yellow	Extract the color with lukewarm water from the sample of pulses, add drops of HCl. A pink color indicates presence of metanil yellow.
Green vegetables like peas, bitter gourd	Malachite Green	Take a cotton piece soaked in water or vegetable oil. Rub the outer green surface of the vegetable. If the cotton turns green, then it is adulterated with malachite green. Place a small portion of the peel (from the green side) on a moistened white blotting paper, green colour on paper indicates the presence of malachite green.
Black Pepper	Papaya Seeds	Pure black pepper settles at the bottom whereas papaya seeds float on the surface of water.
Saffron	Colored dried tendrils of maize cob	Pure saffron will not break easily. Pure saffron when dissolved in water will continue to give out colour till it remains in water.
Common Salt	Chalk	Stir a spoonful of salt in water. Chalk will make the solution white and other insoluble impurities will settle down.

As a part of its mandate to ensure safe food to the citizens, Food Safety and Standards Authority of India (FSSAI) conducts testing of food for different types of adulterants, chemical and micro-biological contaminants and other safety parameters for food. The food testing is done by FSSAI through a network of FSSAI notified laboratories across the country. The food safety officers collect samples of food products for testing. A consumer can also get the samples of food tested in such labs. If the food is found unsafe after testing, the cost of the test is reimbursed to the consumer.

Adverse effects of food adulteration on health

Adulteration is detrimental to health. Many a times food is adulterated in such a way that it looks the same but soon it may change in taste, appearance and nutritional composition, often leading to harmful effects on health. Consuming adulterated food can cause the symptoms like diarrhea, vomiting, headache, abdominal cramps, fatigue, etc. Sometimes its impact may not be instantly visible but may distort the functioning of the immune, digestive and nervous system. It can also lead to liver disorder, heart disease, paralysis, brain damage, cancer, etc. Consumption

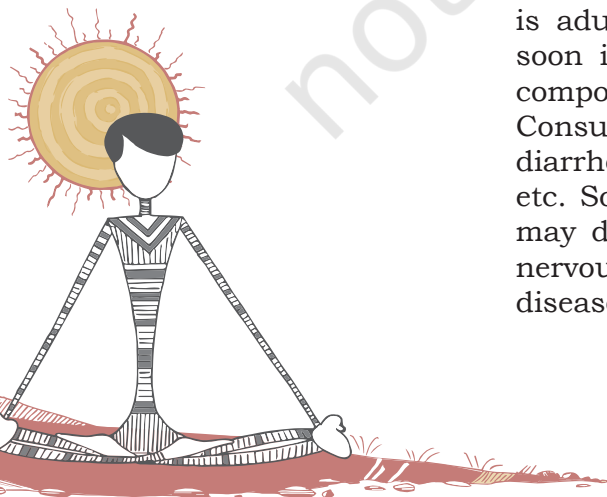

of adulterated food by pregnant women may lead to abortion or damage the brain of the baby. Children, pregnant and lactating women, elderly people, weak and sick persons are at higher risk of consequences of food adulteration.

Actions to be taken against food adulteration

1. Buy food products having standard mark like FSSAI, AGMARK, etc.
2. If you suspect adulteration in any food, do not buy or consume it.
3. Make others aware of suspected adulteration by various modes — personal, print media and digital media
4. Lodge a complaint to 'Prevention of Food Adulteration Department' in your city, town or district.
5. Always preserve grocery bills. These will be needed in case of lodging a complaint to a company, manufacturer, distributor, store-keeper or shop-keeper or to consumer court under the Food Safety and Standards Act.

Effects of pesticides on health

Pesticides are chemicals used in agriculture to protect crops in the fields, during storage and to control insects and pests in the surroundings, e.g., mosquitoes and cockroaches. These can be chemical or biological in nature. Chemical pesticides have played a significant role in increasing food production, but unnecessary and excessive use of these over a long period of time has adversely influenced various forms of life on earth, as well as, the quality of soil, water and environment. These have disrupted the natural balance of the ecosystem.

Pesticides often leave their residues in food which are passed on to the body. Those at higher risks are workers handling or producing pesticides as pesticides are toxic in nature. The adverse effects of pesticide residues depend on the type and amount of the pesticide and the route (ingestion or inhalation) and duration of exposure. If pesticide is used in accordance with good agricultural practice, the residual level would be low and consumption of such foods will not be harmful. Symptoms of acute poisoning include vomiting, diarrhea, abdominal pain, dizziness and numbness. In severe cases, it may lead to difficulties in breathing, blurred vision and convulsion. Pesticides can cause damage to the brain and nervous system, liver, kidneys and are specially harmful to fetus. In India, FSSAI is responsible for setting maximum residue limits (MRLs) for the pesticides.

Activity 9.7

- Search any two cases of food adulteration (personal experience, news item, internet, etc.), identify adulterant and its effect on health.
- Whom can you approach when you see fungus on bread; suspect water in milk or find ice cream sold after the expiry date?
- Conduct a survey on 10 persons to assess their actions on food safety asking simple questions like whether they check sign of quality standard (FSSAI, Agmark etc.), date of expiry, ingredients, visual condition of product, package, etc., while buying. Make a report and discuss in class.

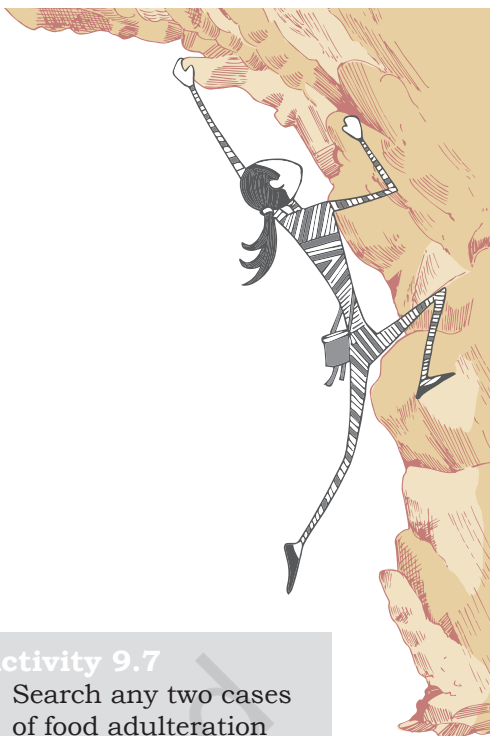

Activity 9.8

- Find out one herbal formulation suitable for home gardening.
- Find out good practices of use of pesticides.

Some preventive measures

- Young children, pregnant and lactating women, weak and sick persons are at higher risk, hence they should be specially protected.
- Use herbal or bio-pesticides.
- Wash fruits and vegetables thoroughly under clean running water.
- Use organic food.
- Keep the pesticides in locked cabinets, away from kitchen and bathroom.
- Read all labels and warnings carefully before using pesticides.

Suggested readings

1. *Nutrition and Hydration guidelines for excellence in sports performance*. 2007 International Life Sciences Institute — India, National Institute of Nutrition and Sports Authority of India.
2. National Institute of Nutrition, Indian Council of Medical Research. 2011 *Dietary guidelines for Indians- A manual*
3. <https://archive.fssai.gov.in/home/safe-food-practices/E-BOOKLETS.html>
4. <https://foodsmart.fssai.gov.in/DART.pdf>



ASSESSMENT

I. Solve this Nutrition Puzzle

Horizontal

1. Which nutrient is the main source of energy for sport person?
2. This is one of the factors affecting meal planning.
3. The practice of adding unwanted material in food.
4. Emissions of intense energy capable of penetrating tissues.

Vertical

1. In India this authority certifies foods for safe consumption.
2. Milk and meat help to build the body because these contain this nutrient.
3. This branch of study deals with food composition and its effect on the body
4. Which compounds are used for food crops but can be injurious to health?

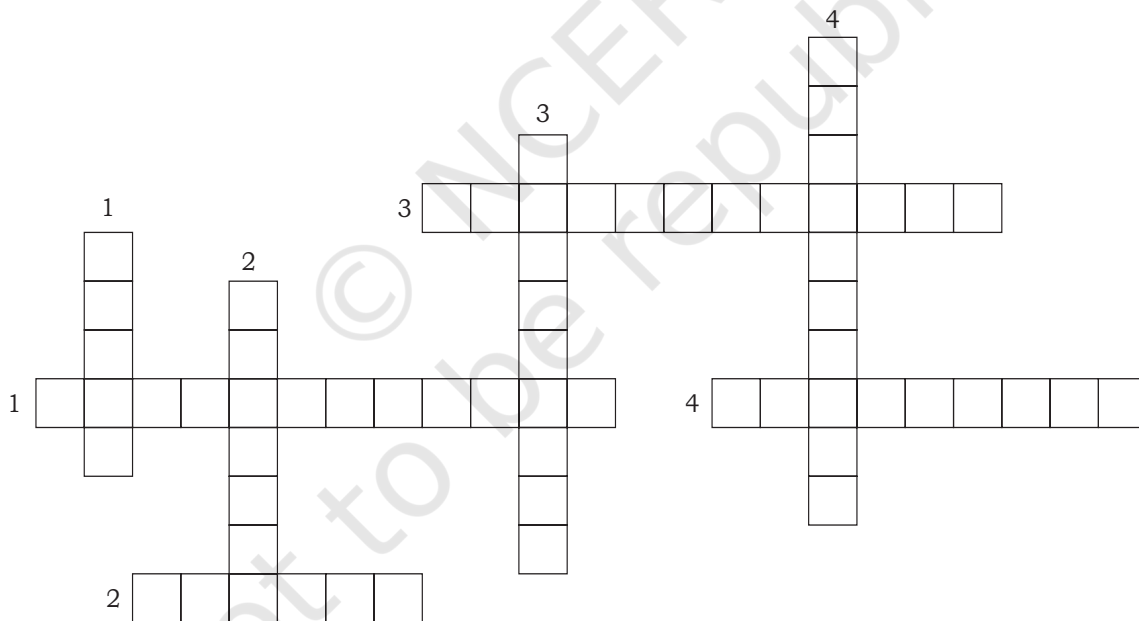

II. Answer the following Questions

1. 'Without dietary planning it is difficult to meet the requirements of people' — discuss this statement giving suitable reasons and examples.
2. In a group there is a male teacher, a female doctor, a 15-year-old girl playing tennis and a man aged 68 years. List the factors that will be applicable for dietary planning of this group.

3. What kind of diet do sportspersons need? Substantiate your answer giving reasons.
4. Write notes on
 - a) Food quality
 - b) Food preservation methods
5. 'Even the most nutritious food may not be safe to eat if adulterated' discuss the statement giving cases/examples in the light of what you know about food adulteration?
6. Suggest a method to detect:
 - a) Metanil yellow adulteration in arhar dal
 - b) Papaya seeds adulteration in peppercorns
7. What are the various ways of protection from harmful effects of pesticides?
8. Which of the following is food adulteration?
 - a) Adding a preservative
 - b) Abstraction of a constituent of food article
 - c) Using a food color
 - d) Splitting of a food article in small pieces
9. Match the following
 - a) Turmeric (i) Caution
 - b) Microbial load (ii) Anti inflammatory
 - c) Pesticides (iii) Shelf life
 - d) Semi-perishable (iv) Food Quality
10. Discuss the classification of food based on shelf life. Take an example of a semi-perishable food and explain various methods of increasing its shelf life.





SAFETY MEASURES FOR HEALTHY LIVING

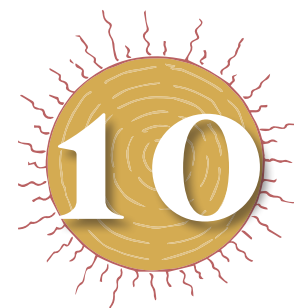

Our ancient scriptures give great emphasis on safe and sound life. Rigveda says, “Self preservation is the first law of nature.” Thus, safety and security should be our primary concern. However, injuries and accidents cannot be predicted. These may occur anywhere and anytime. If they are not managed properly, they may have consequences like physical or mental disability. Therefore, they need to be prevented and managed properly. We try to minimise accidents with the help of safety measures. In this chapter we will be learning about precautions to keep ourselves safe and secure. First aid is essential before advanced medical care is available. Drug or substance abuse and its effects and prevention are also discussed in this chapter.



1077CH10

SAFETY AT THE WORK PLACE

Many injuries and accidents are reported at work place as well as in playfield. Factors like congested space, faulty equipments, improper methodology and carelessness cause these. For example, while working with chemicals in chemistry laboratory, working with equipment in physics laboratory or on playground, one needs to be careful. Every action (with or without equipment) govern with proper rules and methodology which are helpful to minimise chances of accidents.

Safety while working with machines

Machines, whether hand operated or automatic, make life easy and comfortable. But they may be the cause of physical injuries and accidents if not handled carefully. There are certain dos and don'ts for safety while working on machines —

- Wash hands to remove oil and grease or use chalk powder for proper handling.
- Avoid wearing loose clothes. They can get entangled with machines.

Activity 10.1

- Enlist and paste pictures of the safety equipment's or gadgets of any five sports of your choice.
- Name the tablets kept in grain containers to control grain insect.
- Enlist five household insecticides.

Do You Know?

Types of pesticides are

1. Insecticides
2. Larvicides
3. Herbicides
4. Fungicides
5. Bactericides
6. Rodenticides

- Concentrate on work and avoid talking.
- Switch off electricity if the machine is not in use.
- Keep extra or spare parts carefully in proper places so that they do not fall on any one.
- Avoid touching the moving parts of any machine. This may tear-off the skin or cause burn due to heat.

Certain safety equipment and gadgets are used in various areas —

- Helmets
- Spectacles
- Gloves
- Apron
- Insulating Boots
- Face Mask

Handling insecticides

Insecticides are chemicals or herbs to kill or drive away household and agriculture pests like rats, cockroaches, etc. While they are safe to use if proper instructions are followed but carelessness may cause serious accidents.

Common insecticides are —

1. sprays – agricultural insecticides that kill crop pests.
2. tablets kept in grain containers to control grain insects.
3. naphthalene balls – used in cupboards and drawers to preserve clothes from clothes moth.

Certain dos and don'ts for safety while using insecticides are —

1. household insecticides
2. agriculture insecticides
3. insecticide tablets in grain containers

Household insecticides

- Spray cans should be kept away from children and destroyed after use.
- Keep the nozzle of the insecticide container away from children.
- Container used for spray need to be shaken well before use otherwise the liquid content may spoil your hand.
- One should read the information brochure attached with container and avoid frequent use of sprays.
- One should not keep the windows and doors closed for long after the spray.

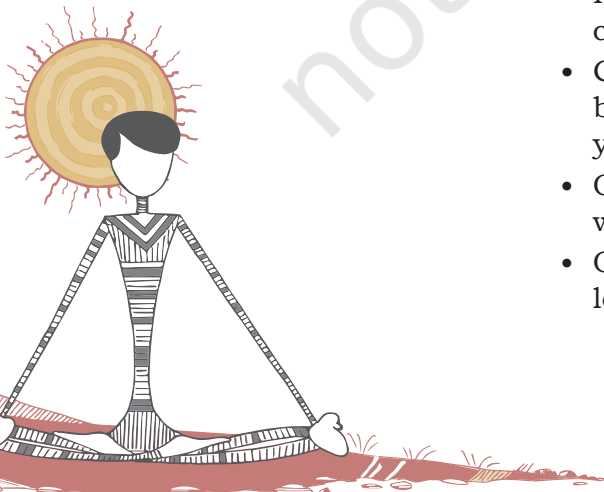

- If accidentally sprayed on your body parts, immediately wash with plenty of water and soap.
- If pesticide is accidentally sprayed on your clothes, remove them immediately.
- Do not use if any member of your family suffers from allergy and asthma.

Agriculture insecticide

In addition to the precautions mentioned above, remember to —

- cover your body parts with a dress used for this purpose. Wash this thoroughly after every scheduled spray and do not use it if not washed and dried. It can cause serious insecticide poisoning.
- cover your eyes and face with spectacles and mask.
- take a bath as soon as possible after the spray.

Insecticide tablets in grain containers

- Always use the tablets after tying in a cloth piece.
- Wash hands with soap and water as soon as you touch the tablets.
- Keep the tablets out of reach of children.
- Remove the tablets before boiling rice or giving wheat for grinding.
- Shift the patient to the hospital if a tablet is ingested accidentally.

Handling electricity and electric gadgets

Electricity is a boon for modern civilisation. However, if due care is not taken while handling electricity and electric gadgets, it may prove fatal. For safe use of electric gadgets, follow the guidelines given below —

- Always use MCBs (Miniature Circuit Breakers) installed at main switch board.
- Immediately change the heated sockets and switches if there is sparking.
- Always read the accompanying instructions before using the gadget.
- Do not touch any electric switch or gadget with moist hands.
- Do not leave the electric gadgets on, if not being used.
- Always wear shoes or rubber slippers while using a gadget to prevent electric shock in accidental leaking of current.

Do You Know?

Insecticides are chemicals or herbs to kill or drive away household pests like rats, cockroaches etc.

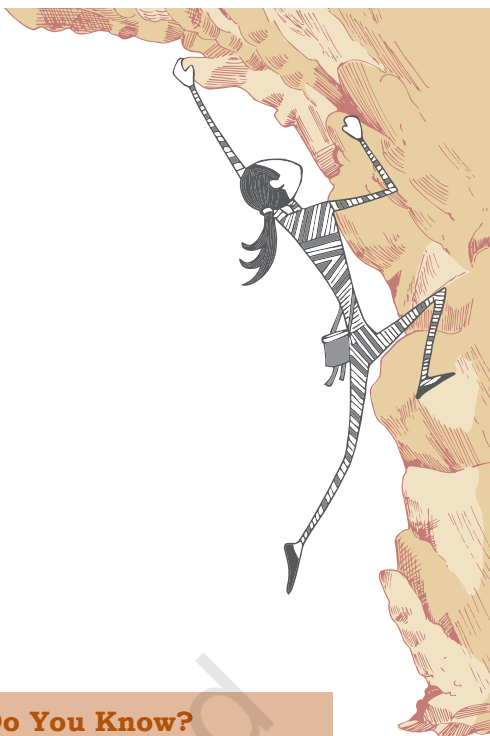

Activity 10.2

- Discuss with your classmates the need of first aid.
- List the most essential items in a First Aid Box and draw a diagram.

Do You Know?

C-A-B means —

- compression
- airways
- breathing

It helps to perform CPR.

- Never try to repair the gadgets yourselves, if you are not trained.
- Always switch the electric supply off before and after using the gadgets.
- Never be in close proximity with electric wires, fire and water. Always use dry sand in case of fire to douse it.
- Always get the servicing of the electrical gadgets done as per schedule.
- Use government approved (ISI mark), electrical gadgets and fittings.

FIRST AID

You must have met with certain emergency situations when you needed urgent medical treatment but it was not available immediately. You might have seen someone helping a person by providing first aid and then in reaching the hospital.

What is First Aid?

First aid is the immediate and essential temporary care given to a wounded, injured or sick person, in an emergency situation to reduce the suffering of the patient, prevent further complication of injury or sickness before availing professional medical assistance.

Priorities of First Aid

Remember the following priorities before giving first aid —

1. Maintain ABC
 - a) *Airway*: Clear the airway if blocked
 - b) *Breathing*: Check breathing and give artificial respiration if necessary.
 - c) *Circulation*: Give chest compressions if heart has stopped
2. Check and stop bleeding by applying pressure
3. Immobilise broken bones
4. Cool the burns
5. Treat eye, nose and ear injuries
6. Tie simple bandages and dressings over wounds
7. Transfer the patient to the nearest health centre

When is First Aid required?

There are many conditions where first aid is required. You have studied a few in Class IX.



The can be following situations may arise where you might need to provide first aid —

The person is unconscious and not breathing

Here CPR (Cardio Pulmonary Resuscitation) is required. It is a life saving measure used when the heart and breathing has stopped.

Starting CPR within three minutes of heart stoppage is very important or else brain will be damaged.

Cardio Pulmonary Resuscitation (CPR): Circulation is maintained by chest compressions. Draw a line between the two nipples and keep the heel of the hand over the centre of this line. Place the other hand over it and give chest compressions pressing down the breast bone 1.5 to 2 inches.

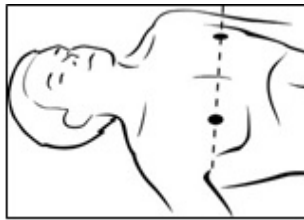

Fig. 10.1: Giving chest compressions

The ratio of chest compressions to breathing should be 30:2 (i.e. 30 chest compressions and 2 artificial breaths per minute) as we have to provide a heart rate of approximately 100 beats per minute.



Fig. 10.2: Head tilt and chin lift

Open the airway: The airway is cleared by finger sweep if required. Any foreign body, secretion, food, broken teeth or tongue falling back are removed.

The airway is kept open by tilting the head backwards and lifting the chin upwards.

C- Cardio means heart,
P- Pulmonary means lungs and
R- Resuscitation means to revive

Do You Know?

- CPR(CardioPulmonary Resuscitation) must be given soon after breathing has stopped.
- If you are untrained then give CPR only through hands for 100-120 per minute and continue until signs of movements or medical help has arrived.

Activity 10.3

Observe the activity perform by teacher and do activity under the supervision of the teacher.



Fig. 10.3: Performing mouth to mouth breathing

Do You Know?

30 compressions followed by two breaths counts consists of one cycle of CPR.



Fig. 10.4: Recovery position

Activity 10.4

Let us learn about common medicines, their effects and what happens if they are used incorrectly.

Breathing: Breathing is artificially conducted by mouth to mouth technique. Keep your handkerchief over the mouth of the unconscious person. Pinch the nose of the person with one hand while tilting the head backwards and lifting the chin upwards.

Continue CPR till either the person is revived or medical help arrives.

The person is unconscious and breathing

Place the unconscious casualty in recovery position as explained in Fig. 10.4.

- Extend the arm nearest up alongside the person's head.
- Bring the other arm across the person's chest and place the back of the hand against the cheek.
- Grasp the leg just above the knee and pull it up so that the foot is flat on the ground.
- Roll the person far enough for the face to be angled forward.
- Position the elbow and knee to help stabilise the head and body

MEDICINES AND THEIR EFFECTS ON INDIVIDUALS

Medicines are chemicals and biochemical substances which are used to prevent, cure or correct deficiency disorders in the body. Many substances have been used as medicines since ages in one or the other form, but modern times have seen a tremendous growth in terms of types and usage of medicines. While medicines are used to treat diseases and can be life saving, they can harm the body if not used correctly.

Medicines are used in the form of injections, tablets, syrups, creams, lotions, solutions, drops, powder, sprays and straps.

Medicines affect us in many ways. Some of the common ways are —

- Analgesics — reducing pain and in fever.
- Antibodies — killing or weakening microbes and infections.
- Lotions — in burns and allergies, for soothing effect.
- Supplements — correcting deficiencies due to vitamins, nutrients.
- Antipsychotic drugs — modifying the body's response, psychological disorders.
- Vaccines and inoculations and immunisation — Protecting and preventing.
- Hormones — supporting physiological functions.
- Herbal medicines — plants herbs

Although medicines assist us to lead a healthy life free of diseases, there are also certain undesirable effects due to

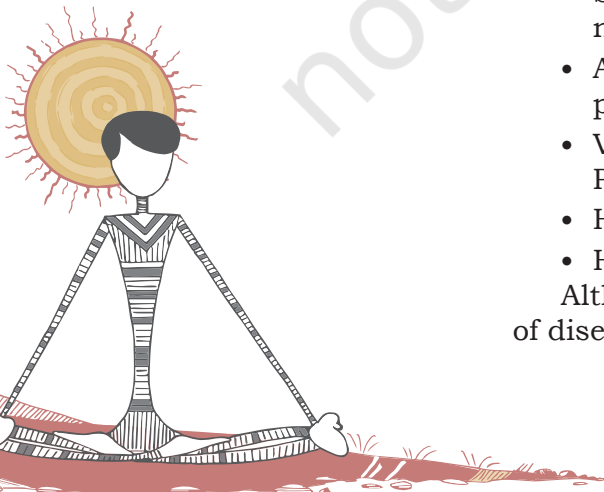

mechanism of action of the medicine or if taken more than the recommended dose. Thus, it is important to take the medicines only under medical supervision.

Precautions while taking medicines

Medicines need to be used in the required dose so that they should not only have the desired effect but also prevent undesired side effects. Some of the precautions while taking medicines are —

- Take medicines only if prescribed by a doctor. Self medication may be dangerous.
- Take the recommended dose of the medicine and at the prescribed interval. Only then there will be desired effects. One should never adjust the dose oneself.
- Do not minimise or exceed the dose and frequency of taking the medicine. This can cause undesirable effects
- Adult dose of medicines should not be given to children. There are special forms and doses of medicines for children. Keep all medicines out of reach of children. Ingestion by them may cause emergency.
- Store the medicines away from extreme temperature and sunlight.
- Always check the expiry date of medicines before consumption.
- Use a full cup of water and drink standing upright while swallowing a tablet.
- Do not take any medicine on an empty stomach unless prescribed by the doctor.
- Keep a list of medicines one is allergic to. Always tell the doctor about such medicine(s).
- Always visit the doctor if one experiences any unusual symptom while taking the prescribed medicines.
- It is important that the medicine should be taken regularly for the entire period and duration as prescribed by the doctor. Otherwise the disease due to infections can return.

SUBSTANCE (DRUG) ABUSE

In an effort to establish their identity and desire for experimentation, adolescents often try out new things. Also they are more amenable to external influences, such as, the media and peers. This makes them more vulnerable to substance misuse, especially when they do not have correct and scientific information. They also lack life skills to deal with the wide ranging negative outcomes of extreme dependency on a substance and thereby, getting addicted to it.

Activity 10.5

What is the use of vitamins in our body?

Do You Know?

Our physiological functions are supported by hormones.

187

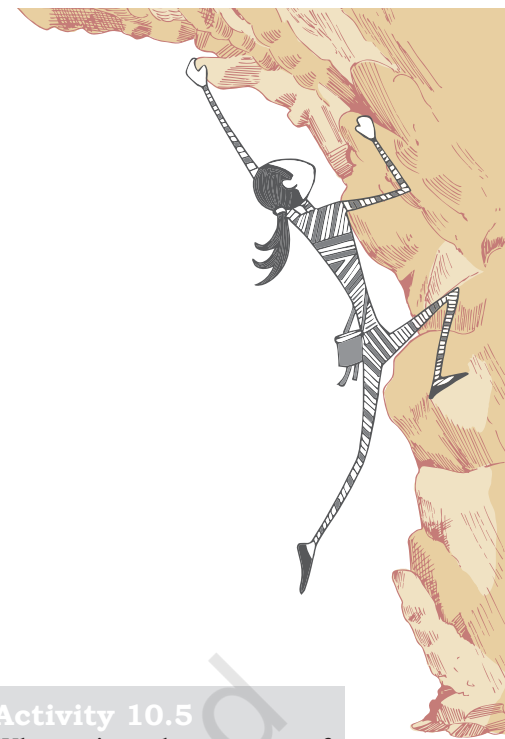

What is substance abuse?

As you have learnt, drugs affect the body by changing the mental and physical status of a person. Some other substances also work in the same way and are not necessarily drugs. The non-medical use of a substance including drugs, that changes an individual's mental and physical status and affect the health adversely, is known as substance abuse.

Once a person starts using a substance, his mental state is altered and the person cannot get out of this habit. The extreme dependency on the substance compels them to increase the intake every day. This is called addiction.

Substance misuse is widespread today including adolescents across the world. Socially acceptable drugs like tobacco and alcohol abuse not only ruins the life of the individual but can also influence them to associated with crime and violence.

Commonly abused substances

There are substances that can be abused for their mood-altering effects such as inhalants and solvents. On the other hand, there are drugs that can be abused that have no mood-altering or intoxication properties, such as, anabolic steroids. They are abused by the adolescents and youth during body building, to look more muscular.

Commonly abused substances are tobacco, alcohol, marijuana (*ganja*), opium, cannabis, solvents (petrol, glue, correction ink) and aerosols inhalants, cough syrup, caffeine, cocaine and ecstasy. There are other substances like *gutka* and *paan* (betel).

These substances can be ingested, inhaled, drunk, chewed or injected by a syringe in the blood. Some of these substances make one addicted, even if taken once.

Reasons for substance abuse in young people

Young people are more vulnerable to substance abuse due to the following reasons —

- During the process of growing up, poor self-esteem, low achievement at school, performance pressures, etc., are some of the factors that promote substance abuse in adolescence. Resorting to substance use as a means of 'growing up' or fun also makes the adolescents more vulnerable to substance abuse.
- Pressure from peers or friends to try an addictive substance, the urge to gain popularity among friends, and desire to experiment and curiosity to try out new things also make young people particularly vulnerable to substance abuse.

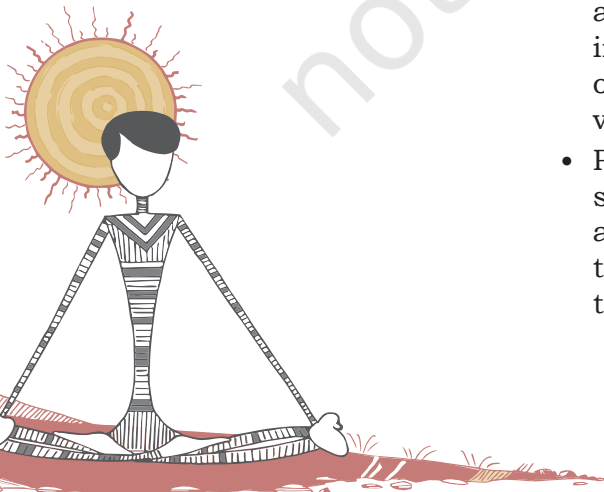

- Previous experience of taking substance.
- Family history of substance misuse.
- Lack of support from family, friends and school.
- Lack of knowledge about the effects and dangers of consuming addictive substances.
- Glamorising substance misuse by media misleads young people.
- Easy availability of substances and drugs are the main reasons for substance misuse in young people.
- Social approval of substance abuse like tobacco, paan, beetel nut, *gutka* chewing or taking wine in parties encourages young people to initiate abuse of these substances.

CASE 1

Sohan has performed well in Class IX annual exams. Now, he is worried whether he will be able to keep up his performance and score good grades in Class X. His parents always tell him how they expect to see him at the top of his class. Afraid of disappointing them, Sohan does not share his concerns with his parents. He feels that some of his friends may be going through the same phase and discusses his problem with them. His friends suggest that smoking may reduce his stress and help him to relax. Sohan wants to feel better and decides to follow his friends' advice. He starts smoking a cigarette or two everyday. Without realising, over a period of six months he was smoking 6-10 cigarettes a day. Smoking has become a habit with him, and in future, it was the cause of his ill health.

Points for Discussion

- What do you think is responsible for Sohan's habit of smoking and why?
- Do you think smoking helped reduce Sohan's stress? Why?
- What else could Sohan have done to reduce his stress effectively?
- What role could Sohan's parents have played to prevent him from smoking?

Consequences of substance abuse

Substance misuse leads to a number of short-term and long-term effects that are detrimental to health.

Short-term effects: These are effects that appear only a few minutes after the intake of substance. The user feels a false sense of well-being and a pleasant drowsiness. Some of the short-term effects are distorted vision, hearing and coordination, impaired judgment, bad breath and hangovers.



Activity 10.6

Discuss how a substance abuser's life gets affected.

Long-term effects: Substances having a long-term impact lead to serious damage due to constant and excessive use. These effects show up over a course of time and are usually caused by progressive damage to different body organs. Some of the health consequences include irregular eating habits, sleep disorders, poor hygiene resulting in poor health and low immunity. This predisposes substance abuser to diseases and infections.

Substance abuse in itself is not a cause of HIV/AIDS or STDs but under the influence of drugs, people may engage in risk-behaviours that make them more susceptible to these infections. Injectable drug users, however, are more prone to HIV in conditions where the users do not sterilise needles and share needles to inject the drug.

Substance users may even die suddenly from a so-called overdose, when one consumes more than what the body can tolerate. Death may also occur from long-term damage to the organs of the body.

These substances are especially harmful if consumed during pregnancy. These substances reach the foetus through blood and harm it by crippling its growth and development or death.

Substance abuse influences not only the individual and family but also the community. The persons who get addicted often lose interest in other activities be it school, job or any other responsibility. They are not able to take care of their responsibilities and may become a liability for their families and finally the society. Furthermore, it is expensive to buy substances or drugs on a regular basis. Hence, in desperation, addicted individuals may be forced to engage in petty severe crimes.

Prevention of drug abuse

Paying attention to the following may prevent young people from misusing substances —

- Peer pressure can be managed by being aware of the implications of substance abuse and developing life skills. One can not only save oneself from adopting risky behaviours under peer pressure but also persuade the peers not to engage in unhealthy behaviours such as substance misuse. Advocacy with the involvement of local community can be quite useful.
- The different ways of dealing with negative peer pressure are saying 'No' assertively, making an excuse, reversal of pressure, and giving reasons.
- Young people should also be educated to recognise that a friend is someone who cares, protects and looks

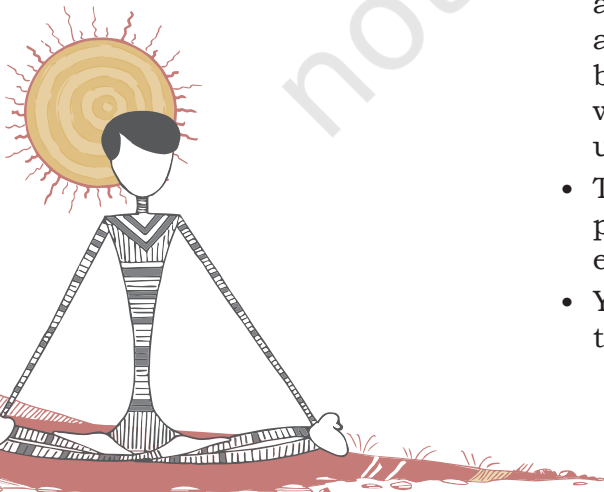

after the welfare of their friends rather than force and initiate into unhealthy habits.

- Young people should be empowered with life skills to know about their body and their life. They should be taking well-informed and responsible decisions.
- The family and society should provide the support system for young children in their 'low' times.
- As the attitudes related to smoking, drinking and misuse of other substances are formed during pre-adolescence and early adolescence, this is an important age to invest in prevention efforts. The family, community and educational institutions should empower young people with correct and scientific information.

Young children should be encouraged to get engaged in socially productive activities. For example, one can start a learning centre for the lesser advantaged children in the neighbourhood, one can learn Braille and help at blind school, and one can create awareness about water conservation in the neighbourhood. This will help them to channelise their energy, being away from the menace of substance abuse and also inculcate social responsibility



ASSESSMENT

I. Answer the following Questions

1. State three precautions one should take while working with a machine.
2. While opening a bottle containing liquid insecticide, the liquid fell on your clothes. How can you prevent its harmful effects on you?
3. Electrical gadgets are used in all households. What are the requirements of these gadgets which will prevent you from getting an electric shock?
4. What do you understand by First Aid? What are the priorities you should keep in mind before administering first aid?
5. What is CPR? When and how is it practised?
6. Why should you not practise 'self-medication'?
7. What do you understand by the term substance abuse?
8. List the long term effects of substance abuse. If your friend falls into the trap of substance use, what will you do to dissuade him?

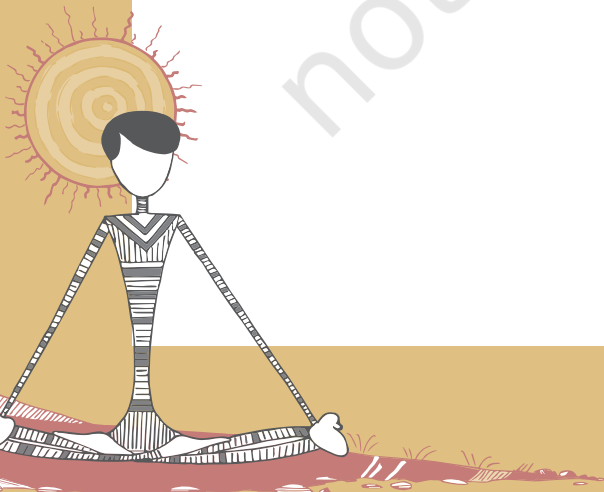



HEALTHY COMMUNITY LIVING

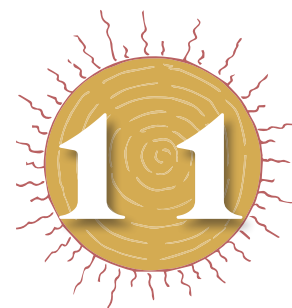

The quality of life in any community is a strong indicator of the health of its members. Our socio-economic needs are such that people depend upon each other as we cannot live in isolation. We live together and collectively share certain amenities that are necessary for our day-to-day existence. In the previous classes (Class VII to IX), we read about the negative effects of unhygienic or filthy surroundings on our health. Regular access to basic amenities, such as, clean water, sanitation, garbage disposal facilities, health care services, recreational facilities, etc., are important for prevention of illnesses and diseases. For prevention of diseases like coronavirus, maintaining of *social distance* is very important. In this chapter, the essential features of healthy community living including social distancing during coronavirus will be discussed. The focus will also be on the principles of cooperative living to ensure healthy living conditions for one and all.



1077CH11

HEALTHY COMMUNITY LIVING

Our way of life, and the utilisation of resources, decide the quality of our personal and community life. A healthy way of living in the community is ensured not only by the optimal use of resources but also by keeping our environment clean and hygienic. Let us understand what is meant by healthy community living.

The following figures show community life in three different situations —

1. A village (Fig 11.1)
2. A township in an urban area (Fig 11.2)
3. A slum in an urban area (Fig 11.3)

A village

Mawlynnong Village in East Khasi Hills District of Meghalaya was declared as Asia's cleanest village in 2003 by Discover

India Magazine. It is about 75 km away from Shillong, the capital of Meghalaya. Most of the houses in this village are beautifully decorated with flowers and plants. As per the Census of 2011, the total population of Mawlynnong is 414. The main occupation of the villagers is agriculture, but it has also been an age old tradition of ensuring that the surrounding environment is clean. In fact cleanliness is a collective effort and this practice is ingrained in the people since their childhood. The people voluntarily sweep the roads and lanes, water the plants in public areas and clean the drains. A dustbin made out of bamboo is found all along the village. Everyone makes it a point that dirt and waste are not thrown anywhere. All the waste from the dustbin is collected and kept in a pit, which the villagers use as manure. Trees are planted to restore and maintain nature's balance. Mawlynnong's fame as the cleanest village in Asia, is drawing a lot of domestic as well as international tourists, as a result of which tourism is also an important source of employment for the local youths. Besides, there are many interesting sights to see such as the famous living root bridge in the nearby village of Riwai, which is a fascinating example of indigenous methods of conservation and sustainability. Local youths are available as enthusiastic and informative guides.



Fig. 11.1: Mawlynnong Village

A township in an urban area



Fig. 11.2: A modern township



This picture is of a modern township derived from an advertisement in a national newspaper. Many times, catchy slogans such as ‘Get away from noise, pollution, congestion and a cramped life’ are used by builders to sell their apartments. People are assured a safe and healthy environment with not only the basic amenities, but also other features, such as, shopping arcades, clubs, gymnasiums, gardens, clinics, food market, lots of open space, etc.

A slum in an urban area



Fig. 11.3: A slum area

These pictures characterise life in a slum area in big cities. As you can see in the picture, people live in overcrowded houses surrounded by stagnant water which is a potential breeding ground for mosquitoes. We also find railway tracks adjacent to the houses which is dangerous for children and adults too. In addition, we find heaps of garbage scattered around the houses.

Activity 11.2

You may conduct a survey in your neighborhood and collect information on the following —

- Make a list of some of the basic amenities and community resources that are collectively shared by members of your community.
- Make a list of some of the community resources that are not available in your locality.
- On the basis of your observations and survey, complete the following table —

Features appropriate or necessary for healthy community living	Features not appropriate or necessary for healthy community living
1. Water supply	1. Open drains
2.	2.
3.	3.
4.	4.
5.	5.

Activity 11.1

After observing the pictures, discuss the following —

- Do you think Mawlynnong Village is a successful example of healthy community living? Give reasons for your answers.
- Do you think modern townships as depicted in Fig 11.2, can offer its inhabitants a safe and healthy environment, as assured by the builders?
- The pictures shown in Fig 11.3, does not reflect signs of healthy community living. Do you agree? Give reasons for your answers.

These activities will enable you to understand various features of healthy community living. Through these activities, you may have observed that in a community, a group of people live in a particular local area. Secondly, they share common facilities, which differ from place to place. In some areas, people have access to facilities, such as, water supply, sanitation, garbage disposal facilities, health care services, recreational facilities, community centre, schools, transportation, etc., but in some places people do not have access to even the most basic amenities.

A community is said to be healthy when its members continuously work together to maintain, improve and expand the available natural resources and avoid their wastage. The healthy community only be developed when its members recognise their roles and responsibilities. They strive to inculcate values and attitudes of cooperation, mutual respect, tolerance, kindness, etc. The role of Panchayati Raj, civil societies and other government institutions is also very important to promote healthy living.

Important features of healthy community living

Maintaining cleanliness of our home and surroundings is an essential feature of healthy community living. Healthy community is one in which all residents have access to quality education, safe and healthy homes, adequate employment, transportation, physical activity and nutrition. Living in overcrowded and unhygienic places with excessive noise and pollution, may lead to various forms of illnesses, diseases and stress. For instance, lack of adequate space, poor ventilation in rooms and toxic fumes in the air, increase the risk of air borne diseases. Access to basic amenities such as regular water supply, safe drinking water and sanitation, is important for healthy community living. In the previous classes (Classes VII to IX), it has been learnt that open and unattended garbage dumps are a potential breeding place for flies, cockroaches, insects and so on. Stagnant water and open drains breed mosquitoes, the carrier of diseases, such as, malaria, dengue and chikungunya. Water borne diseases, such as, cholera, jaundice, diarrhea and gastroenteritis are also resulted due to water pollution.

Access to basic amenities also includes other provisions such as electricity, hospitals, dispensaries, housing facilities, roads and transportation, schools, colleges, employment, security, recreational facilities and so on. Imagine a situation when a member in the family falls seriously ill and requires urgent treatment. What would happen to this person if there are no hospitals in the nearby city, or no transportation facilities to reach there?

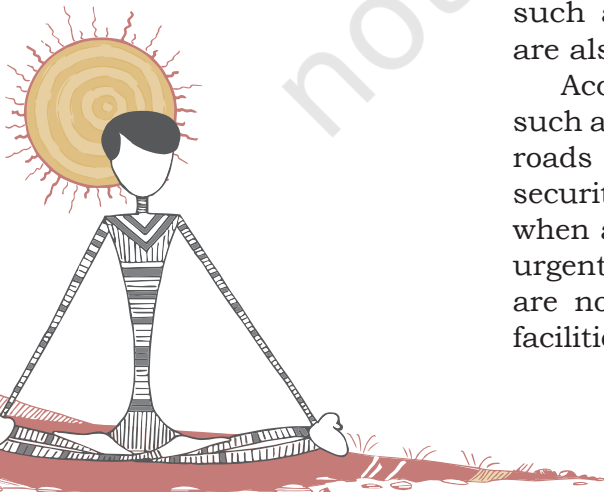

To ensure these basic amenities, the role of the local government or panchayats is very important. They are required to ensure rules and regulations for safety measures, cleanliness, ensure equal access of public amenities to all members, promote adoption of waste management practices, and help ecological restoration and conservation. However, we cannot depend solely on the government to take the initiative. The quality of life in a community also depends on how the members of the community work to improve on available resources and ensure that the government provides for these facilities.

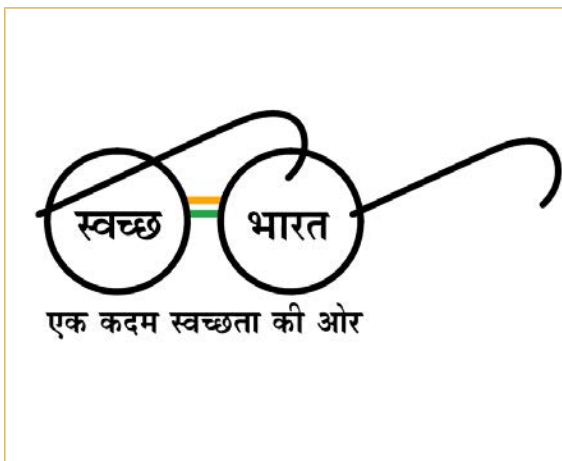

You might have seen this logo before. This is the logo of the *Swachh Bharat Abhiyan*. You must have also seen some of the television advertisements through which the government advertises the importance and necessity of staying clean and keeping our environment clean. In this Clean India campaign — known popularly as the *Swachh Bharat Abhiyan*, the vision of a Clean and hygienic India, once seen by Mahatma Gandhi, can happen only if members of every community cooperate and accept individual and collective responsibility of keeping themselves, their homes and their surroundings clean.

In order to work collectively, members of a community need to develop values of co-operation, kindness, respect, gratitude, joy, peace and selflessness. These attributes are important in fostering the principles of collective work and in nurturing healthy social relationships. The example of Mawlynnong village shows that high income alone is not the only criterion for healthy living. Cooperative action, responsibility and positive values can also help in improving the quality of life, and healthy living conditions for one and all.

PREVENTION OF CORONAVIRUS: SOCIAL DISTANCING AND DEALING WITH STIGMA

Prevention through social distancing

Social Distancing: Deliberately increasing the physical space between people to avoid spreading illness and staying at least one meter away from other person decreases chances of catching coronavirus (COVID-19).

Social distancing: Dos

- Stay at home unless absolutely necessary.
- Keep a distance of at least one meter between yourself and another person.

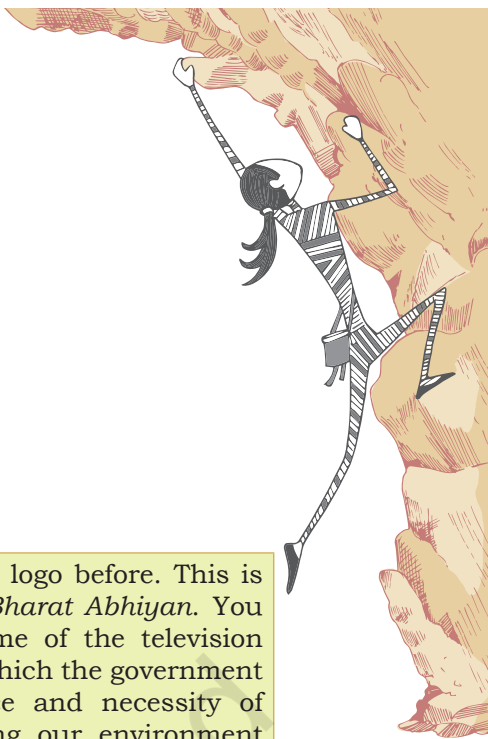

Social distancing: Don'ts

- Do not hold events where people have to gather (even if it is a corner meeting with three or four friends, or an evening chat on the chaupal).
- Do not go to crowded places like markets, shopping, melas, parties.
- Do not use public transport.

Courtesy: <https://www.mohfw.gov.in/>



Fig. 11.4: Social distancing dos and don'ts

Dealing with the stigma

What is stigma?

In any epidemic, it is common for individuals to feel stressed and worried because they fear —

- falling ill and dying.
- approaching health facilities due to fear of becoming infected while in care.
- losing livelihoods, not being able to work during isolation, and of being dismissed from work.
- being socially excluded or placed in quarantine because of being associated with the disease.
- feeling powerless in protecting loved ones and fear of losing loved ones because of the virus or being separated during quarantine.
- feelings of helplessness, boredom, loneliness and depression due to being isolated and not working towards caring for a dependent.

Stress is caused due to the above fears and being treated as an outcaste or blamed for spreading the disease.

What is the reason behind the stigma?

The level of stigma associated with COVID-19 is based on three main factors —



- COVID-19 is a new disease about which many things are still being discovered.
- When something is unknown people are worried which leads to fear.
- Rumours or fake news give wrong information and spreads the fear.

Recognising the stigma

It is very important to recognise stigma and handle it. Below are four case studies related to these issues. Read these case studies and recognise the stigma.

CASE 1

You are in the grocery shop, there are several people who are wearing a mask. You see Babulal, the store owner, going red in his face as he tries to suppress a cough.

CASE 2

Sukhram has come back from Pune where he works as a taxi driver. They stay in a joint family and you have taken his contact history as advised by your supervisor. You come to know that Sukhram's family members have asked him to leave the house.

CASE 3

Beauty works in Delhi as a house maid. recently she has come back and you have been told that beauty's employers have asked her to leave as she had a cold.

CASE 4

Surali is a young girl of 11 years. She and her 8-year-old brother are staying with an aunt as their parents have been asked to go in for isolation. Surali's aunt keeps on complaining to you that the children are a big burden on the family's resources.

What will you feel like if you were Babulal, Rani, Sukhram and Beauty?

- Babulal has simple cough. But he is too scared to cough in front of people as he will lose the customers.
- Sukhram needs family support to help him stay in isolation. If everyone takes proper precautions the infection need not spread.
- Beauty has a seasonal cold but she has been asked to leave by her employers.
- Surali and her brother are two small children who need to be supported and this kind of incident can cause mental stress even in the future. Child Protection Cell (CPC) should be approached for appropriate measures for helping children in difficult situations.

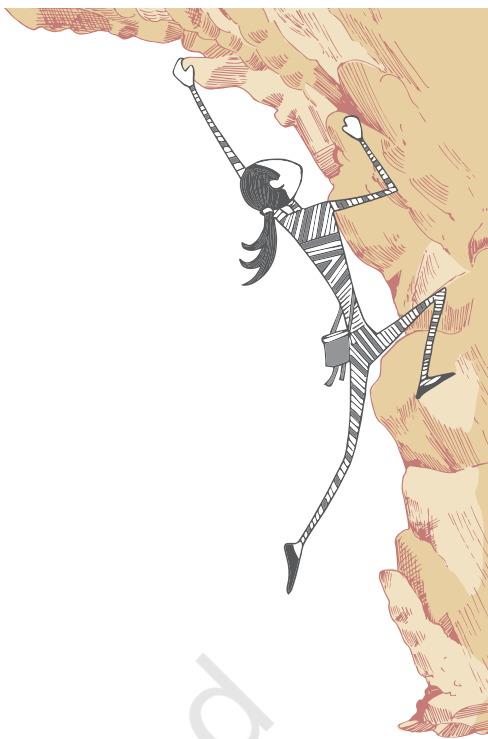

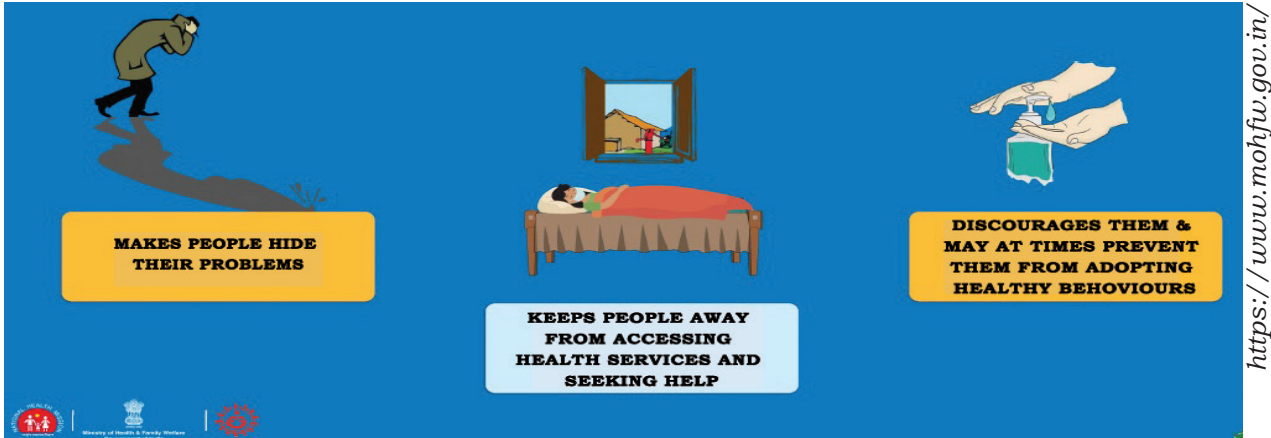

Fig. 11.5: What does stigma do?

VALUES AND ATTITUDES CONDUCIVE FOR HEALTHY AND COOPERATIVE LIVING

How to develop values and attitudes conducive for healthy and cooperative living? These values have to emanate from within a person, but they can also be developed through various other ways. Camping can be seen as one of these ways which is extremely appropriate for students, particularly during the adolescent period.

What is camping?



Fig. 11.6: Camping

Youngsters might have already attended a camp or may have heard about camping activities from friends. Camping is an outdoor activity, where familiar surroundings are left to spend a night or several nights at an outdoor site. The location of these sites varies as per the objectives of the trip, time of the year and budget available.

Common camping sites are: visits to villages or rural areas to understand their pattern of living; mountain areas, national parks, lakes, beaches, forests, etc. One can also plan camping activities in a nearby place, such as, open fields, park, or even in an open space of the school premises. The basic camping equipment include tents, cooking utensils or gadgets, sleeping bags, first aid kits, ropes, insect repellents,

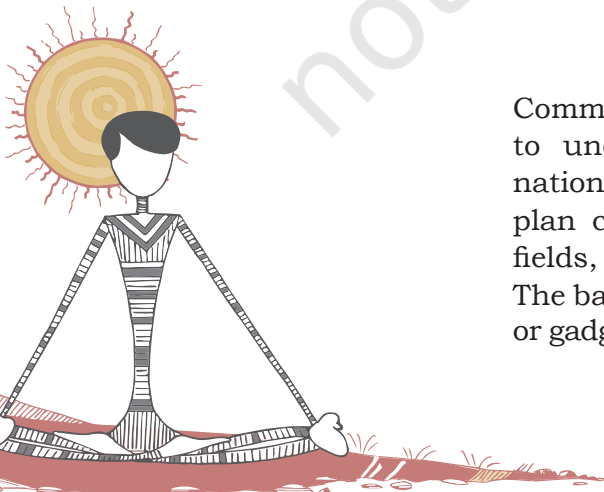

etc. These requirements will vary as per the location of the camping site and objectives of the trip. However, irrespective of the location, the essence of all camping activities revolves around two main features —

- (i) Bonding with nature
- (ii) Importance of living in a community.

Importance of camping

Camping gives students a good break, away from the monotony of the classroom. It gives an opportunity to learn from nature in a joyful, exciting and adventurous manner. Living in the natural environment with students from different areas, cultures, religions and backgrounds, help them to learn to work as a team in various activities. These activities differ from adventurous and challenging ones, to the most basic ones, such as, cooking, cleaning, collecting water, etc. In this process, students learn the importance of self-reliance, teamwork, co-existence, importance of natural resources and organisational skills. Camping also offers great opportunities for empowerment of the girls.



Fig. 11.7: Trekking



Fig. 11.8: Mountaineering



Fig. 11.9: Rock climbing

While camping, one can engage in adventure sport, such as, trekking, river rafting, mountaineering, rock climbing, repelling, paragliding, caving. Adventure sport help to develop courage, self-confidence, leadership qualities and enhance concentration powers. This is also a great form of physical exercise. However, these activities should be conducted only in the presence of qualified and professional trainers. Joining the National Cadet Corps (NCC), National Service Scheme (NSS) or Bharat Scouts and Guides will also give you opportunities to take part in these activities.

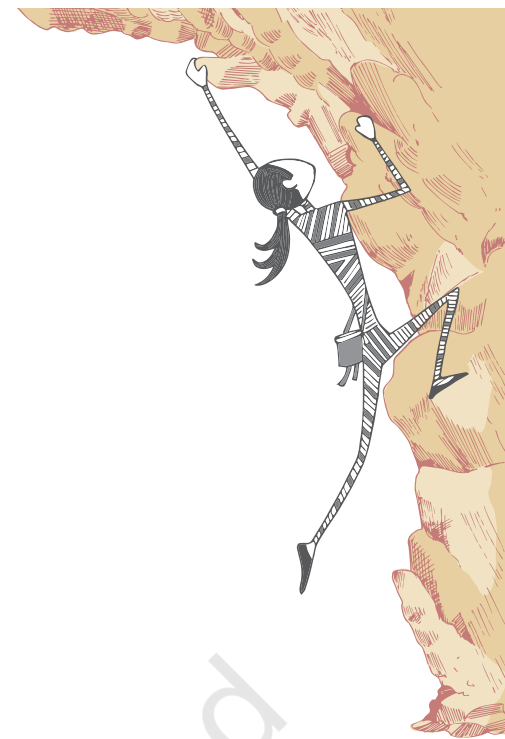



Fig. 11.10: Zipline



Fig. 11.11: River rafting

A guided walk through the forest helps to explore nature. It can also complement much of the textual data in your geography and science textbooks through direct experiences. At the same time, learn to appreciate the beauty and simplicity of nature to make all understand how much disconnected from 'Mother Earth one has become.' You realise the importance of nature and how we should take care of it. Moreover, through interaction with local communities, one learns about edible and medicinal plants, local crafts, first-aid and various other sustainable forms of living.

During the evenings all may gather around campfires which give a great opportunity for social bonding. Campfires also enable to learn about different cultures through story telling, songs, dances, skits and games. On many occasions hidden talents of individuals are brought out during these activities.

Activity 11.3

Some of the camping activities have been given in the following table. Write down the qualities which can be developed through the respective activities. You may consult other sources for your answers.

Activities	Qualities developed
Hiking, rock climbing, trekking, rope climbing, river rafting, etc.	Confidence, leadership qualities, team-work
Nature walk	
Cultural activities — patriotic songs, lectures on Indian culture and heritage through dance, drama, songs, story telling, skits, quizzes, etc.	
Campfire — story telling that emphasize on moral values based on local folk tales, history, games and songs.	
Interaction with local community members on local crafts, medicines, first aid, food, etc.	
Yoga	
Voluntary services	

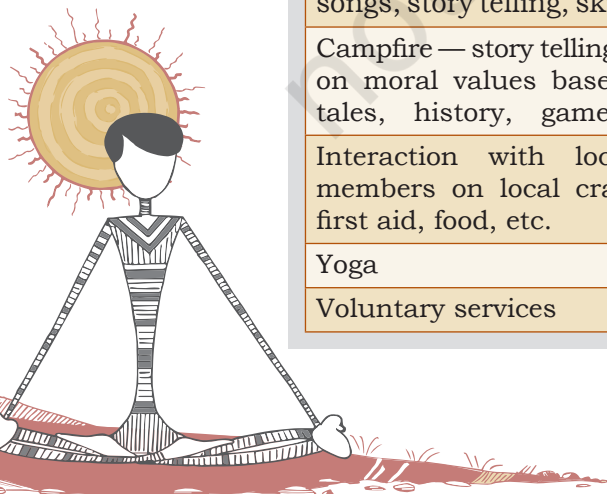

ASSESSMENT

I. Multiple Choice Questions

1. Which of the following is the most important criterion for healthy community living?
 - a) Cooperative action
 - b) Kindness
 - c) Harmony
 - d) Safety measures
2. Community participation is essential for _____.
 - a) ecological restoration
 - b) public hygiene and health
 - c) social harmony
 - d) All of the above

II. State whether True or false

- a) Maintenance of public hygiene is the sole responsibility of the government.
- b) Community health and individual health are closely interlinked
- c) Camping is the only means for developing values of cooperative living
- d) Overcrowding increases the risk to air borne diseases
- e) Interpersonal relationships are as important as our physical environment.

III. Answer the following Questions

1. What is your vision of a healthy community? Give at least 3 examples.
2. A camping trip has been arranged by your school. Two girls from your community are not allowed to go for the trip. What are the points you would highlight to convince the parents on the importance of camping trip for girls.
3. Arrange a collage of pictures showing various activities in a Camping Trip.
4. Give two suggestions for keeping your community healthy, both at the individual and collective level, based on the points enumerated below.

For example,

Record your suggestions regarding cleanliness drive within the community. The first one has been done for you.

I will ensure that, I do not throw litter around.

We will ensure that, there are no open garbage dumps in the community.

- a) Record your suggestions regarding rules and regulations within the community for safety measures.
I will ensure that _____.
We will ensure that _____.
- b) Record your suggestions for ensuring equal access of public amenities to all members.
I will ensure that _____.
We will ensure that _____.
- c) Record your suggestions for adopting effective waste management practices.
I will ensure that _____.
We will ensure that _____.
- d) Record your suggestions for ecological restoration and conservation within your community.
I will ensure that _____.
We will ensure that _____.
- e) Record your suggestions for ensuring kindness and consideration to the aged and differently abled.
I will ensure that _____.
We will ensure that _____.
- f) Record your suggestions for counseling provisions for the youth, recreational facilities, etc.
I will arrange for _____.
We will arrange for _____.
10. Imagine that you have been asked to prepare an activity schedule for a day in a camping trip. First write down the location of the camping site and objectives of the camping trip and include other details in the following table.
Location of camping site _____.
Objectives of the camping trip _____.

Table : Schedule for a camping trip

Time	Activities	Equipment Required	No. of participants	No. of Teachers/Instructors	Expected Outcome	Budget

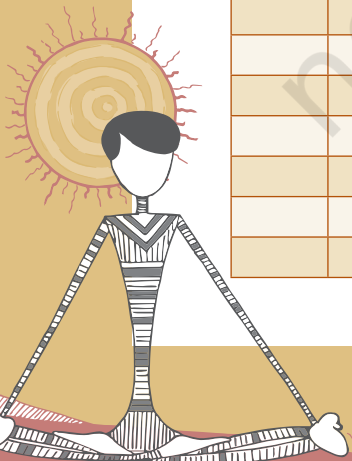



SOCIAL HEALTH



You have already learnt that, 'Health is a state of complete well-being and includes physical, mental, emotional and social health, Many animals show remarkable social behavior. Humans too are social animals and much of their behaviour is based on social norms laid down by the human societies since time immemorial.

Therefore, social health is a very important issue for all human beings — men-women, young-old, educated-uneducated, rich-poor. Those children who learn to become socially healthy remain so all their lives. This chapter, will deal with the ways and means of growing up as socially healthy individuals and also helping them to clarify myths related to coronavirus.



1077CH12

Myths and facts related to coronavirus

Statement: A person with coronavirus can recover fully and not be infectious any longer.

Fact: 80 per cent of the people have recovered from the disease without needing special treatment. But information on the virus treatment is still being researched.

Statement: Eating raw garlic, sesame seeds will protect you against the virus.

Fact: Garlic is a healthy food that has other benefits but does not protect you against the coronavirus.

Statement: The virus can die easily once it is out of the body.

Fact: We do not know about this particular virus as of now. Similar viruses (SARS, MERS) survive from 8 to 24 hours depending on types of surfaces.

Statement: You can get COVID-19 through mosquito bites

Fact: The coronavirus cannot be spread through the bite of a mosquito. It is spread through droplets spread when an infected person sneezes or coughs.

After learning this lesson one should be able to explain what is social health, help all to remain socially healthy and spread awareness about benefits of social health.

WHAT IS SOCIAL HEALTH?

Activity 12.1

Read the following conversation between an old grandfather, Mr. Das and 12-year-old grandson's friend Ravi.

Mr. Das : How are you Ravi and how is your grandfather?

Ravi : I am fine but my grandfather always feels angry and unhappy. He criticises everyone all the time, so no one wants to sit and talk with him. He is boring and not as loving as you are. Why does he behave like that Dadu?

Mr. Das : It is because he has been unwell for a long time. Your grandpa is not getting company from any one, this makes him feel lonely and isolated. In other words, he is suffering physically, as well as mentally due to his old age. He gets angry because he is unsure of himself now and annoys others by his comments. He does not think that he is acceptable in society now.

Which is why, he expresses his frustrations by being rude to others without any reason and fault of theirs.

Why don't you spend time with him? Talk to him about your friends, your day in school, a happy incident, a sad one also and you may observe the change in him within a few days.

Ravi : Thank you, Dadu. Now I understand that if someone is sick and emotionally unhappy, he would likely be angry and alienate others.

Answer in brief

1. Give reasons for the loneliness of Ravi's grandfather.
2. State situations that made Ravi think his grandfather was alienating others.
3. Say yes or no
 - (a) Do you agree that physical, mental and social health are interrelated?
 - (b) Living with others harmoniously requires a person to be socially healthy. State the reason for your choice.

Activity 12.2

- You are in a tricky situation. Your best friend had a fight with another friend and you have seen that your best friend is at fault. You are asked to intervene to bring back peace. Will you announce that the cause of the fight was your best friend? This may become a source of annoyance to your best friend but if you did, that is Justice.
- If you help, the two boys become friends again, that is fraternity.

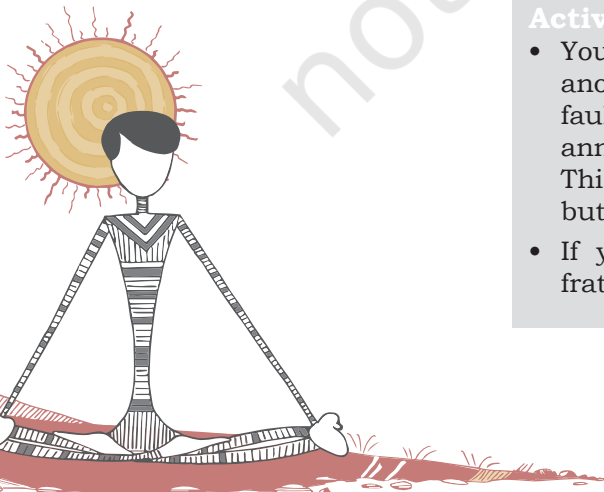

- Your friend Arun noticed that food was being distributed free of charge on the footpath. A boy wearing tattered dirty clothes was repeatedly being sent to the end of the queue. Arun held the boy's hand and insisted that the boy be given the food packet then and there and not at the end. Arun believed in Equality of opportunity for all.
- If you listen carefully to others opinions on a subject even if they do not match yours and try to understand others' viewpoints, you believe in liberty.

Read the preamble to the constitution of India given at the beginning of all NCERT text books. It is reprinted here for you. (photocopy of preamble of constitution).

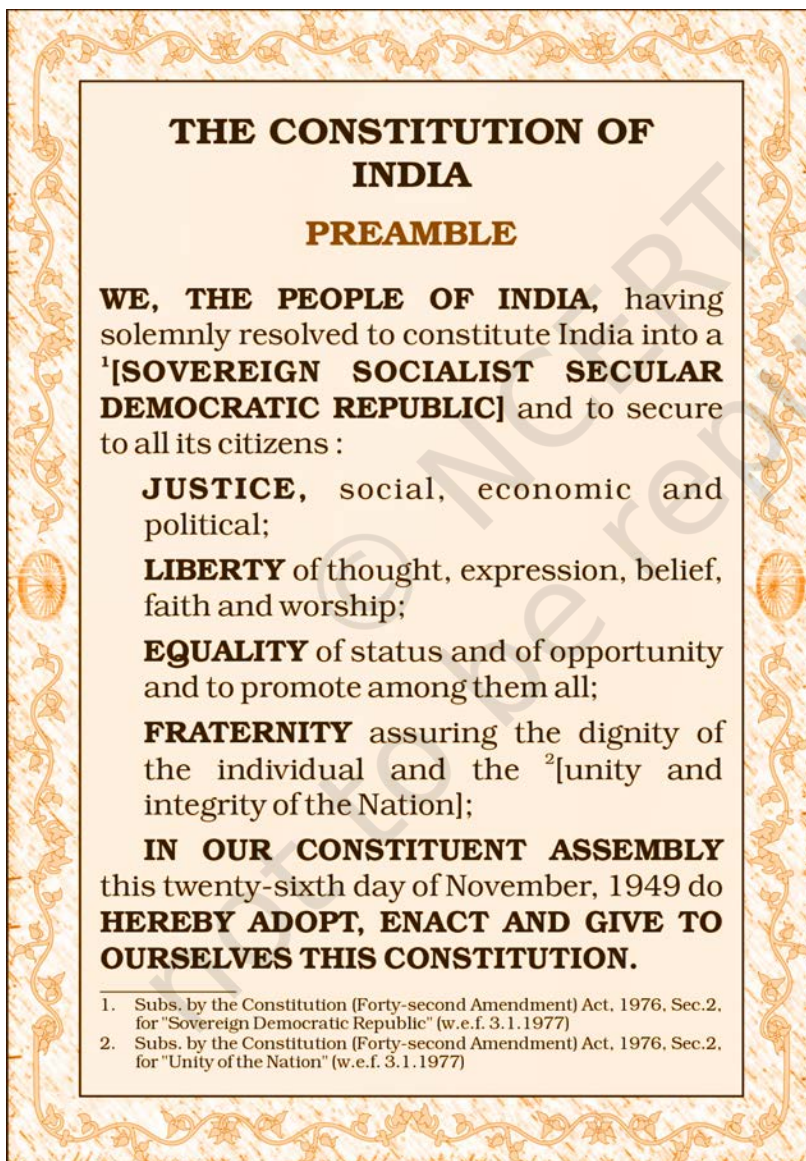
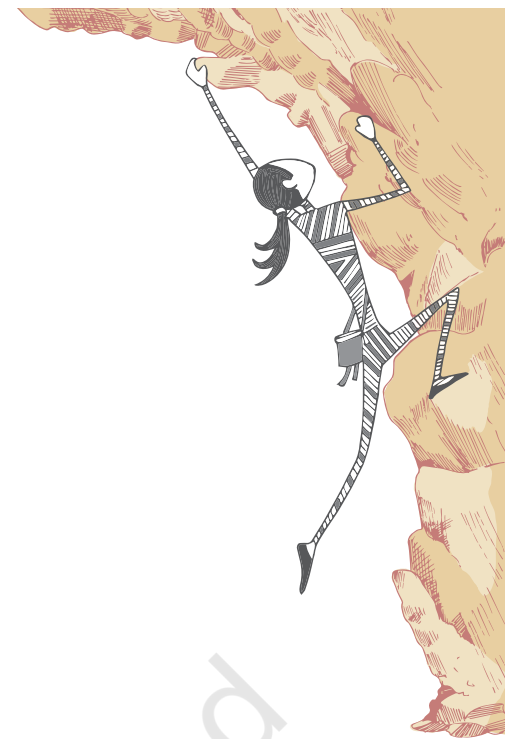

Fig. 12.1: Preamble to the Constitution of India



Everyone is a member of a social group and everyone is part of their peer group, family and kin, community, city, region and country, as well as the physical and biological environment. Would you agree that the country's constitution provides for Justice, Liberty, Equality and Fraternity which should be adopted in life for living happily and having consideration for all others in the group? Let us understand these four terms of our constitution which are directly related to "social health of a person or a country", and then try to define social health. In other words, if one is socially healthy, than will be able to develop interpersonal relations, through maintaining equality, fraternity and justice.

Let us now try and define social health.

DEFINITION OF 'SOCIAL HEALTH'

Social health may be defined as the ability to form satisfying interpersonal relationships with others. One who is able to make positive relationships and acquires the ability to adapt in different social situations and act appropriately as per the situation concerned, and can be called a socially healthy person.

Need for developing social health

Primitive humans were hunter-gatherers, who lived in small groups or clusters and spent their lives at individual levels. Around 10,000 years ago, they moved near rivers to grow their own food and began to live together. With the passage of time, they started to live in a society and developed a language for interaction with each other. As 'human society' progressed, an individual became part of many social groups for example a member of a peer group, a family and kin, a class in school, a native of a region and a citizen of one's country. Social changes occur from time to time and many societies lay down norms and values for group living. Urbanisation has brought about many changes which are different from traditional rural societies.

Social attributes, of people however, remain the same as they are based on interrelationship between members of any society and necessary for accomplishing tasks requiring teamwork. School is one of the platforms for learning social skills.

ROLE OF VARIOUS INSTITUTIONS

Promotion of social health among children requires collective efforts and appropriate skills. All people in the field of education have to think about this.

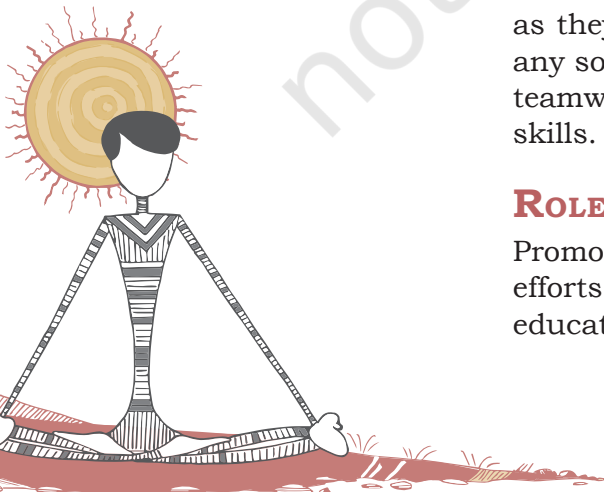

Role of teacher training institutes and other organisations

School teachers need a degree, diploma or certificates from a teacher training institute. There are a number of organisation concerned with school education. The syllabus of teacher training courses should include the topics of important issues for children of which health should be one.

Organisations such as NCERT, SCERT, DIET should periodically organise workshops, publish journals and provide inservice training programmes on health issues including social health.

Role of schools in promoting social health

Schools have a very significant role to play in the promotion of health and safety of children. They spend a lot of time in school in early years. School environment forms ideal setting for acquiring knowledge of healthy choices of food. It is in school that they participate in physical activity through sports, games, yoga, gymnastics, exercise and gain benefits of each. School helps children to learn social skills which assist in establishing lifelong healthy behavior. Children learn team spirit and training in rules and regulations of social wellbeing just as in the defense services, which are inbuilt in training of defense service personnel, so they work together as a team to protect our nation.

In order to promote social health, the school should have a positive environment where children mingle with teachers, peer group and non-teaching staff without fear and apprehensions. Teacher have a significant role in this regard.

Role of teachers

It is well known that teachers are the mentors and therefore, the teacher training institutes should make training in leadership and mentorship a part of teacher training. Also well known saying that 'example in better than precept' Students easily learn to be socially healthy if the teacher herself or himself sets an example rather than lecture on social health. A good teacher ensures that students grow up into physically, mentally and socially healthy individuals. In doing this the teacher has to make efforts to ensure that students —

- (i) eat a proper diet and perform regular exercise and physical activity which are requirements of good physical health.
- (ii) inculcate friendship between classmates, indulge in amicable behavior with others in school so that students develop a helpful nature. These are necessary for mental and emotional health.

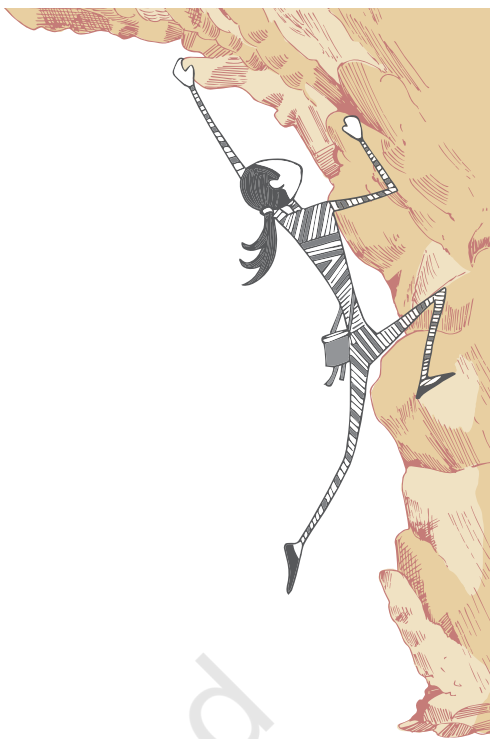

3. Teachers should train students in learning life skills like —
- empathy and self awareness
 - effective communication so that they develop healthy Interpersonal relationships
 - problem-solving and decision-making to learn to be stress free
 - creative and critical thinking
 - coping with stress and emotion.

The above are absolutely essential for developing social skills in order to be socially healthy.

Social skills help a student to have a desirable self image and self esteem and also self confidence. This makes children acquire ability to live harmoniously in the society.

Role of technology in building social health

Technology has made communication convenient through Mobiles, Skype, Facebook, Twitter, Instagram and E-mail messages. Knowledge about different media can help to develop the skills to access the appropriate media for accurate information on a specific topic or issues. More so, because media brings awareness, and provides access to global knowledge and learning. But refrain from using mobiles and viewing the T.V. for long periods as that tends to be counter-productive and reduce interaction time with others. This makes us socially withdrawn. Although media is a source of information, all of it may not be true or reliable. It is advisable to seek guidance from a trusted adult while accessing media and internet. Moreover, there is a need to understand about real and fake news or information as these affects our attitude and behavior.

Role of students in building habits of social health

Social health comes from social skills. A few important guidelines for promoting social skills are outlined below.

- Building self awareness is an important skill:* Practice self-care by developing habits of cleanliness and hygiene, keeping away from substance abuse, engaging in physical activity and regularly consuming a balanced diet.
- Do not be blameful and judgmental:* Remember when you point a finger at others, three fingers of yours point towards you. Hence indulge in knowing yourself better. It helps to discriminate between a good and a bad act of yours and helps to make friends. Empathy and self awareness go hand in hand. When you see a child hitting an animal, tell that

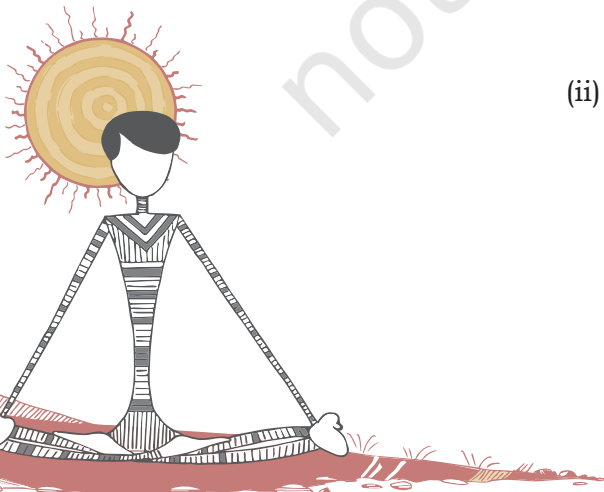

child that if they were hit, they would feel the same pain. That is empathy for others and leads to self awareness.

- (iii) *Learn to identify your own mistakes:* There is no harm in saying sorry for a mistake and rectifying it. People will have faith in you if you did so.
- (iv) *Make an effort to reconnect with old relationships and friendships:* The socially healthy person makes an effort to contact and meet old friends, to remember enjoyable periods of childhood which can be a good way to beat stress and spend leisure time.
- (v) *Appreciate yourself and others:* But never let your ego rule your behaviour which can sometimes drive you to lose a relationship.
- (vi) *Try and be respectful, positive and supportive* towards the needy, the physically and mentally challenged, the downtrodden and those belonging to faith and cultures other than yours. Lend an ear to others opinion. It teaches tolerance. Tolerance and appreciation are virtues in socially healthy individuals.

Role of family in inculcating social skills in young family members

The importance of family in inculcating social skills among children is paramount. Guardians or parents are the prime teachers and caretakers who feed them healthy food and are also their play mates. They have to be aware themselves to be role model and make children appreciate as they grow. The benefits of enjoying nutritious food and being aware of a balanced diet is of paramount importance. Watching of television for longer duration is bad for students. Parents themselves have to be cautious in what they do in front of children and how long they are in front of the TV. However, at the same time good TV programmes are an avenue for learning. Encourage them to indulge in physical activity to build their muscles and bones. Fit body and fitness depends primarily on proper diet and healthy body and mind. The parents and elder family members need to guide them in social skills. Parents and elders have to be accessible to children for necessary guidance. They form a “safety network’. They are to guide adolescents through advice, answer their queries and occupy them through activities to keep them away from involvement in addictive substances like tobacco, drugs and alcohol which they might believe are helpful in tiding over stress. However, these substances have deleterious effects on the growing body.



WHAT ARE LIFE SKILLS?

These are —

- *Empathy*: Is the ability to understand another's feelings in a particular situation.
- *Self Awareness*: Is the recognition of one's character, strengths, areas of growth, beliefs and values.
- *Effective Communication*: Is having skills of communication that facilitate interaction with people in positive ways.
- *Interpersonal Relationships*: Building relationships of friendship and goodwill with all others.
- *Problem solving*: Is the ability to resolve challenges.
- *Decision Making*: Is the quality of analyzing problem to find and act to reach an appropriate solution.
- *Creative thinking*: Is the ability to do something in a novel manner.
- *Critical Thinking*: Is the capacity to analyse multiple perspectives and objectively evaluate the same.
- *Coping with Stress and emotional distress*: These refer to management and regulation of one's emotions and moments of stress.

All these life skills help to develop desirable social health and live happily in a society.

1. The teacher needs to play an active role in discouraging her students from engaging in socially unhealthy practices such as vindictive attitudes, selfishness, jealousy and culture of hatred. For this, teacher has to sacrifice time and energy. It is however, necessary for a teacher and school authorities to understand that more than finishing the syllabus and passing exams, it is the teacher's responsibility to build good human beings. Home has a large role to play but it has been the mission of teachers to contribute towards grooming students into socially healthy adults
2. Another role of a teacher in inculcating 'social health' is to have a friendly, stress-free atmosphere in class. This can happen if students are engaged in 'group activities', especially activities for 'experiential learning'. Members of groups are reshuffled from time to time for team activities so that students may understand that it takes all kinds of people to make the world and the socially healthy groups can live in harmony despite differing in opinions. Group activities build team spirit and remove boredom.

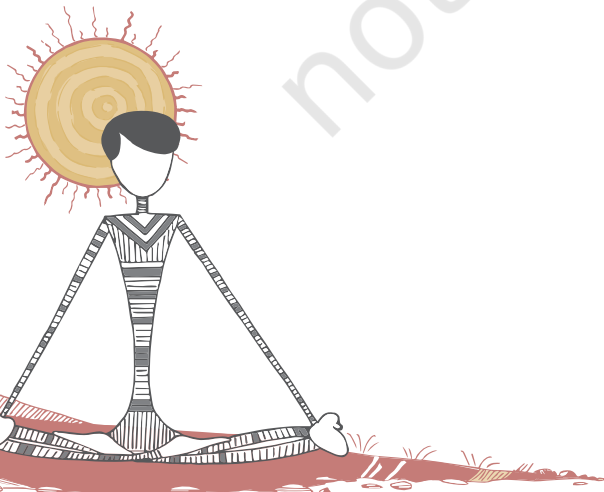

IDEAS FOR PROMOTING SOCIAL HEALTH OF STUDENTS

1. If there is a canteen, permit sale of healthy food like fruits or fruit juices. School authorities should be aware as to what is being sold for consumption immediately outside school and permit only those selling healthy eatables or low fat and healthy snacks.
2. Provide for safe drinking water.
3. Provide for examination and treatment of students with poor health conditions, bad teeth and weak vision. Organise health checks for them.
4. Organise variety of co-curricular activities, and ensure participation of maximum number of students, and training them leadership as well as team spirit.
5. Organise interclass sport and games competitions and finally, a sport day and prize distribution for encouragement.
6. Include a games period every working day in the time table.
7. Seek and insist on cooperation of parents so that even guardians who have not learnt social skills and have unhealthy habits may learn through their participation. It shall be community service by the school and a means to encourage everyone to undertake healthy living.
8. Have events for teaching and non teaching staff and allow voluntary participation in games using school equipment.
9. Have experts for teaching Yoga, Taekwondo, Judo and Karate for self-defense and utilise school premises for the same.
10. Schools can have activities involving children to learn to love and respect all living beings, plants and animals.
11. Encourage team games, 'House system' should be adopted, which helps children to interact with students of other classes too.
12. Organise periodic slide shows or movies with valuable messages.

In this manner students, teachers, parents and community will realise the benefits of being physically, mentally and socially healthy. And what a great way it will be to build a healthy nation!



ASSESSMENT

I. Answer the following Questions

1. Define
 - a) Health
 - b) Mental health
 - c) Social health
2. What do you mean by life skills? Enlist them.
3. What are the characteristics of a socially healthy person?
4. Suggest three ways in which social health can be promoted in children by each of the following —
 - a) School
 - b) Teachers
 - c) Family
5. Write a short story of your choice to express life skills.
6. What kind of society do you envisage if majority of its members are socially healthy?





AGENCIES AND AWARDS PROMOTING HEALTH, SPORTS AND YOGA



Awards and rewards are the essential parts of performance enhancing efforts in health, sport, games and Yoga. It is managed and monitored by specific agencies. There are a number of agencies that promote health, physical education, including sport and yoga in our country. In India there are provisions for various kinds of awards. The chapter shall discuss those agencies and awards that promote health, physical education, sport and yoga.



1077CH13

AGENCIES

There are a large number of agencies that are related to health, physical education, sport and yoga. Major institutions working in the areas of school education, physical education, sport and yoga are as follows:

NCERT

National Council of Educational Research and Training (NCERT) is an apex autonomous organisation set up in 1961 by the Government of India for quality improvement of school education and teacher education. It functions in the areas of educational research, training and development of curriculum and instructional materials for school education. It's another critical role is to assist and advise the Central and State governments on policies and programmes in school education. The major constituent units of the NCERT are —

1. *National Institute of Education* (NIE) undertakes research and development activities related to pedagogical aspects of curriculum, instructional materials and supplementary materials. It prepares national curricular policy documents, develops database and various types of materials and organises in-service training for different target groups.

Activity 13.1

Where is the headquarter of NCERT located?

Activity 13.2

Find out how many clusters are taking part in CBSE competitive sport.

Do You Know?

CBSE has started competitive sports for all private schools affiliated to CBSE since 1988-89.

2. *Central Institute of Educational Technology* CIET is concerned with development of educational technology, design and production of media software. It holds programmes to build competencies of media personnel and need-based researches. It evaluates activities undertaken and studies carried out to assess the effectiveness of materials and programmes.
3. *Pandit Sunderlal Sharma Central Institute of Vocational Education* (PSSCIVE) is located at Bhopal and organises research, development, training and extension programmes related to Work education and Vocational education.
4. *Regional Institutes of Education* (RIEs) are located at Ajmer, Bhopal, Bhubaneswar and Mysore. The RIEs cater to the needs of school education and teacher education (pre-service and in-service education) including those teachers educators in the States and UTs under their respective jurisdictions. Besides these, yet another regional institute, known as North-Eastern Regional Institute of Education (NERIE) is located at Shillong.
5. *NCERT: Role in Health and Physical Education* NCERT as an apex body includes functioning of Health and Physical Education like all other subject areas. The National Curriculum Framework (NCF-2005) prepared by NCERT considers health and physical education a compulsory subject from Class I to X and optional subject at Classes XI and XII. As a follow up of NCF-2005, NCERT has prepared syllabus on health and physical education which has been approved by the National Steering Committee set by the Government of India. Health and Physical Education components have also been included in the pre-service training courses running at each RIE's. It contributes to the policy formulation process of the Central and State governments related to Health and Physical Education.

216

CBSE

Central Board of Secondary Education (CBSE) is the first board of education that was set up in 1921 under jurisdiction of Rajputana, Central India and Gwalior. Government of India decided to set up a Joint Board in 1929 and it was named as the 'Board of High School and Intermediate Education'. Later in 1952, the constitution of the Board was amended and it was named as 'Central Board of Secondary Education'. In 1962 the Board was reconstituted once again with the objectives: (i) to serve the educational institutions

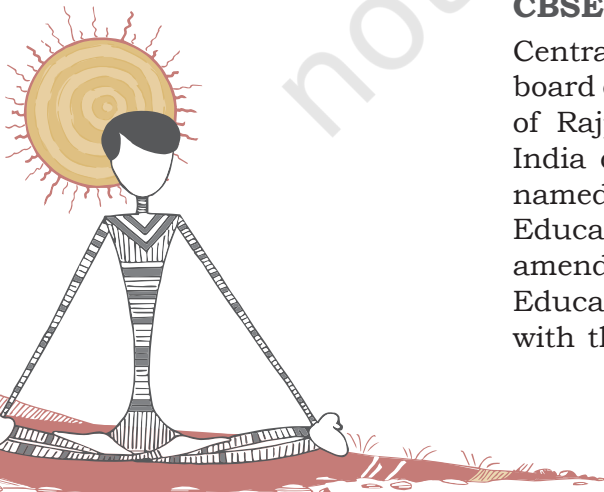

more effectively (ii) to be responsive to the educational needs of those students whose parents were employed in the Central Government and had frequently transferable jobs. The major functions of the CBSE have been to develop curriculum for all the subjects at the secondary and higher secondary levels, to conduct evaluation and examination activities, to organise teacher training workshops, to develop resource materials for teachers and students, to publish some text books for secondary and senior secondary classes and to monitor various academic projects. The CBSE has been preparing syllabi on Health and Physical Education, conducting competitive sport activities for schools affiliated to it and promoting the transaction of Health and Physical Education at secondary and higher secondary levels. It has also been ensuring that the Comprehensive and Continuous Evaluation (CCE) is focused on health and physical education activities.

School education agencies in states

We have found that there are government agencies at the state level for preparing curriculum, training teachers and other functionaries and evaluating the performance of students. There is a State Council of Educational Research and Training (SCERT) in almost all the major States. This institution is responsible for preparation of syllabi and textbooks for all the classes at primary and upper primary stages. In some of the States and Union Territories, the State Institutes of Education (SIE) or the Directorates of Education perform these roles. All these institutions at the state level perform these roles for the subject area of Health and Physical Education also. Then there are State Boards of Education, that are responsible for preparation of Syllabi and textbooks and evaluation of students of all classes at secondary and higher secondary stages. These institutions also conduct in-service teacher training for all the subjects including the subject of Health and Physical Education. Under SCERTs there are District Institutes of Education and Training (DIETs) that are responsible for pre-service teacher education at the elementary stage (primary and upper primary stages).

SAI

Sport Authority of India (SAI) was set up by the Government of India in 1984, aimed to promote sport in India and developing excellence by upgrading the skills of the Indian sport persons. Some of the prestigious institutes run by the SAI are: (i) Netaji Subhash National Institute of Sport, (Chandigarh, Sonapat, Lucknow, Guwahati, Imphal, Bangaluru, Madurai, Kolkata, Patiala and Gandhinagar), and (ii) Laxmibai National College of Physical Education (Thiruvananthapuram).

Activity 13.3

Education is a concurrent subject of the state government.

Activity 13.4

Where is the head office of SAI.

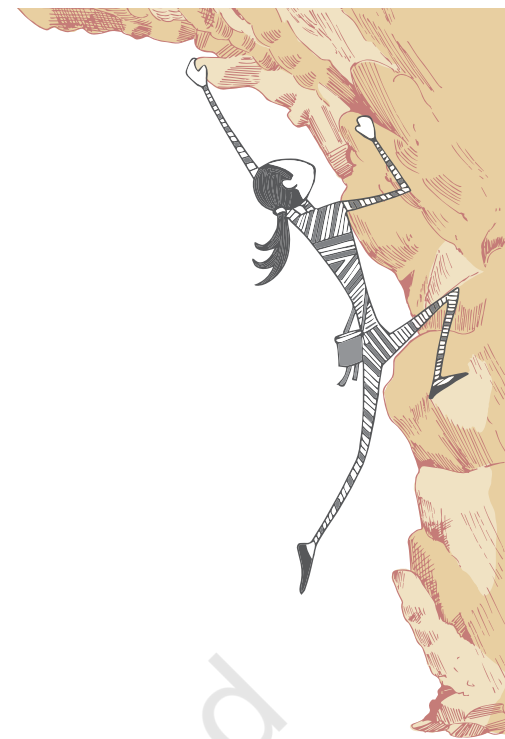

The main objective to establish SAI was to upgrade the skills of the budding sport talents in India. In order to attain this objective 23 training centers spread over the entire country are functioning.

Through various schemes formulated for sub-junior, junior and senior levels, it ensures that the enthusiasm for sport is widened among different age groups of people. SAI has also provided competitive exposures to the talented sportpersons. Some of the SAI schemes formulated for the promotion of sport in India include National Sport Talent Contest. The Sport Projects Development Area and the Sport Hostel Scheme. Besides, the Army Boys Sport Company (ABSC) in association with the Indian Army authorities is also run by SAI. SAI provides facilities like sport equipment for the trainees, kit, stipend as well as coaches. Currently, there are eight ABSCs all over India. Another scheme proposed by SAI is called SAI Training Centers (STC). This Scheme has been successful to a great extent, in fulfilling SAI's objective of spotting and nurturing sport talents. Another ambitious schemes run by SAI are - Special Area Games (SAG), and Centre of excellence (COX), producing high level National/ International sport.

NSNIS

After independence, on May 7, 1961 the National Institute of Sport (NIS) was set up by the Government of India for the development of sport at the Motibagh Palace of the then Maharaja of Patiala. With the objective of developing sport in the country on scientific lines and to train the coaches in different sport disciplines. On January 23, 1973, it was renamed as Netaji Subhas National Institute of Sport (NSNIS). Presently, NSNIS Patiala is Asia's one of the best Sport Institute and is popularly known as the "Mecca" of Indian Sport. It has produced coaches of high caliber and significantly contributed in rendering their expertise and assistance in the preparation of the national teams for various International competitions. The Institute is producing high caliber coaches in sport disciplines through its Diploma in Sport Coaching and Master Course in Sport Coaching. The Institute is presently conducting 6 courses pertaining to sport. (i) Master Degree in Sport Coaching (ii) Post Graduate Diploma in Sport Medicine (iii) Diploma Course in Sport Coaching (iv) Diploma Course in Sport Coaching (for candidates from North-East Region and Andaman and Nicobar) (v) Refresher Course and (vi) Certificate Course in Sport Coaching. (www.nsnis.org)

Other Government Institutions promoting health, physical education, sport and Yoga are Laxmibai National Institute of Physical Education, Gwalior, Indira Gandhi Institute of physical education and Sport Science (University Delhi) New

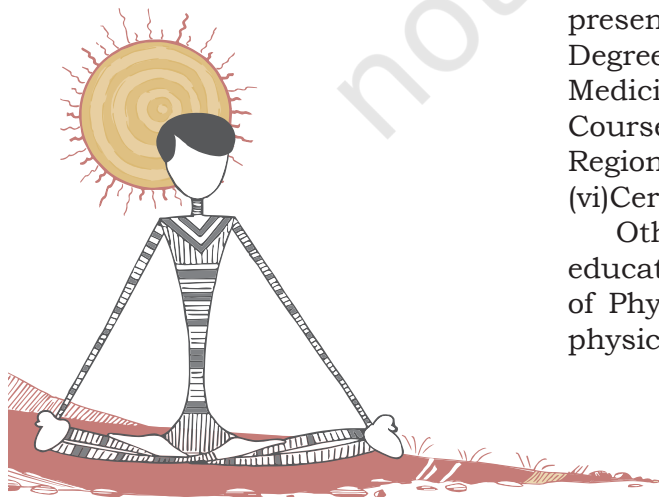

Delhi, Government College of Physical Education, Patiala etc. Besides these there are many other colleges, Faculties and Departments of Physical Education and Sport under various state and central Universities, which promotes sport, games and physical education. Further, a detailed information on various institutions conducting Bachelor's Degree, Post-graduate Degree, Master of Philosophy in Physical Education and Doctorate degree programs could be obtained from their respective websites.

Sport schools

Another important agency is Motilal Nehru School of Sport, RAI which was founded in July 1973 by the Government of Haryana to provide excellent educational facilities with extra emphasis on sport to deserving students. It is a fully residential and co-education school. Besides this there are other sport schools such as: G.V.Raja Sport School, Trivandrum; Maharana Pratap Sport College, Dehradun, Sport College, Lucknow, Sport School Jalandhar etc. that cater to the development of sport in the school education sector. There are also provisions for sport scholarships and sport hostels which prospective students can avail. The information can be obtained from concerned institutions or through internet.

Yoga institutions

There are a number of institutions devoted to promotion of yoga, providing everything from in depth courses to flexible drop-in classes. As the style of yoga and approach to teaching varies at each center, it is important to give proper thought to your needs before approaching the Institute. Some of the Institutes that offer yoga education are as follows:

1. Ramamani Iyengar Memorial Yoga Institute, Pune
2. Krishnamacharya Yoga Mandiram, Chennai
3. Bihar School of Yoga, Munger
4. The Yoga Institute, Mumbai
5. Kaivalyadham Shriram Mahadevi Yoga Samiti, Lonavala, Pune
6. Morarji Desai National Institute of Yoga, New Delhi
7. Swami Vivekananda Yoga Anusandhan Samsthana (SVYASA), Bengaluru
8. Patanjali Yoga Pith, Haridwar
9. Malviya Yoga Sansthan BHU, Varanasi
10. Uttarakhand University of Sanskrit and Yogic Sciences, Haridwar

Additional information about above Yoga institutions could be obtained from their respective websites.

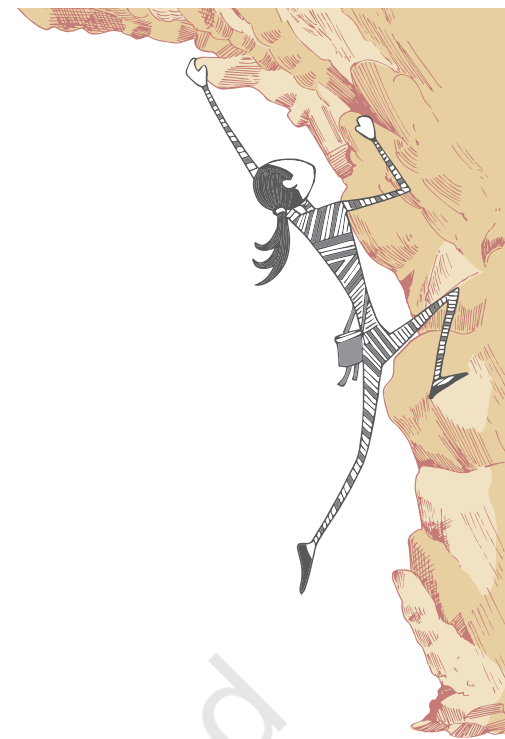

Activity 13.5

Gather information regarding the benefits you can get from different institutions/agencies working in the areas of games and sport, health and physical education and sport training from different sources, such as by discussing with your teachers, sport teachers, and relevant publications or through internet. Identify the types of help you can get from each one of them to promote your abilities in games and sport.

AWARDS IN SPORT

Sport awards in India are presented by the Government of India to honour the players who have performed very well in their field of sport. It is bestowed to various sport personalities in different fields for their accomplishments and outstanding performances and to enhance the enthusiasm of players and recognise their skills and achievements. All the 7 awards are given to the proud recipient on National Sport Day every year i.e. 29 August to mark and celebrate the birthday of hockey Maestro Major Dhyanchand. These awards include the Trophy Rajiv Gandhi Khel Ratna Award, Arjuna Award, the Maulana Abul Kalam Azad (MAKA) Award, the, the Dronacharya Awards and the Dhyan Chand Award. Very recently the sport category also has been added in the list of areas for which Bharat Ratna is conferred.

Rajiv Gandhi Khel Ratna Award

Fig. 13.1: Rajiv Gandhi Khel Ratna

The Rajiv Gandhi Khel Ratna award was instituted in the year 1991-92. It is India's highest honour given for achievement in sport. The words "Khel Ratna" literally mean "Sport Gem" in Hindi. The award is named after the late Rajiv Gandhi, former Prime Minister of India. It carries a medal, a scroll of honour and a cash component of ₹ 7,50,000. The Khel Ratna was devised to be an overarching honour, conferred for outstanding sporting performance, whether by an individual or a team, across all sporting disciplines in a given year.

Dronacharya Award

Fig. 13.2: Dronacharya award

Dronacharya Award was instituted in 1985 to honour eminent coaches who have done 'outstanding and meritorious' work consistently with a singularity of purpose for raising the standards of sportspersons to highest performance in National and International events. As the best sportsperson award is named Arjuna Award, it is appropriate that the coaching award is named after Dronacharya, as he was the Guru of Arjuna. The award comprises a plaque (bronze statuette of Dronacharya), a scroll of honour and a cash prize of ₹ 5,00,000 (Rupees five lakh).



Arjuna Award

The Arjuna Award was instituted in 1961 by the Government of India to recognise outstanding achievement in games and sport. The award carries a cash prize of ₹ 500,000 a bronze statuette of Arjuna and a scroll. Over the years the scope of the award has been expanded and a large number of sportpersons who belonged to the pre-Arjuna Award era were also included in the list. Further, the number of disciplines for which the award is given was increased to include indigenous games and the differently abled category. The Government has recently revised the scheme for the Arjuna Award. According to the revised guidelines, to be eligible for the Award, a sportperson should not only have had good performance consistently for the previous three years at the international level with excellence for the year for which the Award is recommended, but should also have shown qualities of leadership, sportpersonship and a sense of discipline.

From the year 2001, the award is given only in disciplines falling under the following categories:

- Olympic Games/Asian Games/Commonwealth Games / World Cup/World Championship Disciplines and Cricket
- Indigenous Games
- Sport for the Physically Challenged

Dhyan Chand Award

The Dhyan Chand Award is a Life Time Achievement given to the veteran sportpersons of India for their achievements in their respective fields of sport. It is named after Dhyan Chand the legendary Indian hockey player. This is a new award instituted by the Government of India in the year 2002. The award carries a cash prize of ₹ 5,00,000/- (Rupees five lakh), a statuette and scroll of honour. The main objective of the award is to bestow honour on those sportpersons who have contributed a lot to their respective sport by their performance and who still continue to contribute to the promotion of sport after their retirement from the active sporting career.

Maulana Abul Kalam Azad (MAKA) Trophy

Government instituted MAKA Trophy in 1956-57 as a tool for promoting the competitive sport amongst colleges and Universities. The top overall performing University in the Inter-University tournaments in India is given the MAKA Trophy, which is a rolling trophy along with cash prize. The cash prize has also been recently enhanced to Rs.10 lakh, Rs. 5 lakh and Rs.3 lakh for the Universities securing first, second and third position respectively in Inter-University tournaments.



Fig. 13.3: Arjuna award



Fig. 13.4: Dhyan Chand award

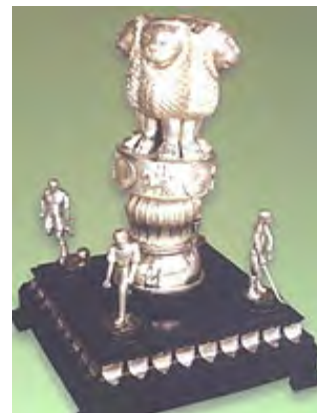

Fig. 13.5: Maka trophy



Fig. 13.6: Rashtriya Khel Protsahan Puraskar



Fig. 13.7: TNNA Award

Activity 13.5

Gather information of the current year's award winners in the field of Games.

Do You Know?

Tenzing Norgay was the first person from India to climb Mount Everest in 29, May 1953.

Rashtriya Khel Protsahan Puraskar

The RKPP award was instituted in 2009 by the Govt. of India to recognise the contribution in sport by entities other than sport persons and coaches. The objective of the award is to encourage and promote corporate involvement in the promotion and development of sport. The award carries a citation and a trophy in each categories, like

1. The community sport identification and nurturing of budding young talent
2. Financial support for sport excellence.
3. Establishment and management of sport academics of excellence.
4. Employment of sport persons and sport welfare measure.

Tenzing Norgay National Adventure Award

The TNNAA was instituted in 1993 by the Govt. of India. It is named after Tenzing Norgay, who is one of the first two individual to reach the summit of Mount Everest in 1953 along with Sir Edmund Percival Hillary. The award is given to individual for Excelling Adventure Activities on land, Sea and Air. It carries a statuette, Certificate and a cash prize of 5 Lakhs.

Other sports awards in India

Apart from the awards that have been discussed so far, there are some other special awards that are given by the Government of India to the medal winners in the international sport events. Some State governments also confer these awards. Generally, the Governments give away some cash awards for winning medals or cups in the international championships, Olympic Games, the World cup or World Championships, the Asian and Commonwealth Games or Championships. The players who become victorious in the game of Chess and Billiards or Snooker as well as the junior sport persons who win medals in the World, Asian and Commonwealth Championships, are also given these awards.



ASSESSMENT

I. Answer the following Questions

1. Explain the role of agencies at the national level that work for Health and Physical Education in schools.
2. Which are the State level government agencies responsible for Health and Physical Education in schools? What roles do they play for the promotion of this subject area?
3. Write brief Notes on the following:
 - a) Sports Authority of India (SAI),
 - b) Netaji Subhas National Institute of Sports (NSNIS),
 - c) Sports Schools
 - d) Yoga Institutions
4. Which are the national awards that are given to sportpersons in India? What are the criteria for conferring those awards?
5. What awards are given to coaches and senior and retired sport persons? What are the bases of giving those awards?
6. Identify those educational and sport agencies that can help you in promoting your abilities and skills in games and sport and explain what kinds of contributions they can make.
7. Write the full forms of MAKA, RGKR, TNNA.

II. Reference

cbse.nic.in
mnssrai.com
ncert.nic.in
performerawards.com
sportauthorityofindia.nic.in
sportforschools.com
www.nsnis.org

THE CONSTITUTION OF INDIA

PREAMBLE

WE, THE PEOPLE OF INDIA, having solemnly resolved to constitute India into a ¹**[SOVEREIGN SOCIALIST SECULAR DEMOCRATIC REPUBLIC]** and to secure to all its citizens :

JUSTICE, social, economic and political;

LIBERTY of thought, expression, belief, faith and worship;

EQUALITY of status and of opportunity; and to promote among them all

FRATERNITY assuring the dignity of the individual and the ²[unity and integrity of the Nation];

IN OUR CONSTITUENT ASSEMBLY this twenty-sixth day of November, 1949 do **HEREBY ADOPT, ENACT AND GIVE TO OURSELVES THIS CONSTITUTION.**

1. Subs. by the Constitution (Forty-second Amendment) Act, 1976, Sec.2, for "Sovereign Democratic Republic" (w.e.f. 3.1.1977)
2. Subs. by the Constitution (Forty-second Amendment) Act, 1976, Sec.2, for "Unity of the Nation" (w.e.f. 3.1.1977)