

Health and Physical Education

Textbook for Class XI



विद्यया ऽ मृतमश्नुते



एन सी ई आर टी
NCERT

राष्ट्रीय शैक्षिक अनुसंधान और प्रशिक्षण परिषद्
NATIONAL COUNCIL OF EDUCATIONAL RESEARCH AND TRAINING

First Edition*July 2020 Ashadha 1942***Reprinted***December 2021 Agrahayana 1943**October 2022 Kartika 1944**March 2025 Phalguna 1946***PD 12T GS**© **National Council of Educational Research and Training, 2020**₹ **295.00**

Printed on 80 GSM paper with NCERT watermark

Published at the Publication Division by the Secretary, National Council of Educational Research and Training, Sri Aurobindo Marg, New Delhi 110 016 and printed at Goyal Offset Works Pvt. Ltd., Plot No. 370–371, 374–375, Phase-V, Sector-56, Kundli, Sonipat (Haryana)

ALL RIGHTS RESERVED

- ❑ No part of this publication may be reproduced, stored in a retrieval system or transmitted, in any form or by any means, electronic, mechanical, photocopying, recording or otherwise without the prior permission of the publisher.
- ❑ This book is sold subject to the condition that it shall not, by way of trade, be lent, re-sold, hired out or otherwise disposed off without the publisher's consent, in any form of binding or cover other than that in which it is published.
- ❑ The correct price of this publication is the price printed on this page. Any revised price indicated by a rubber stamp or by a sticker or by any other means is incorrect and should be unacceptable.

OFFICES OF THE PUBLICATION**DIVISION, NCERT**

NCERT Campus
Sri Aurobindo Marg
New Delhi 110 016 Phone : 011-26562708

108, 100 Feet Road
Hosdakere Halli Extension
Banashankari III Stage
Bengaluru 560 085 Phone : 080-26725740

Navjivan Trust Building
P.O. Navjivan
Ahmedabad 380 014 Phone : 079-27541446

CWC Campus
Opp. Dhankal Bus Stop
Panihati
Kolkata 700 114 Phone : 033-25530454

CWC Complex
Maligaon
Guwahati 781 021 Phone : 0361-2674869

Publication Team

Head, Publication Division : *M.V. Srinivasan*

Chief Editor : *Bijnan Sutar*

Chief Production Officer (In charge) : *Jahan Lal*

Chief Business Manager : *Amitabh Kumar*

Assistant Production Officer : *Sayuraj A.R.*

Cover and Layout : *Bluefish Designs Ltd.*

Illustrations : *Mohd. Fajruddin*

FOREWORD

Health of children is of paramount importance as it affects their educational outcomes, day-to-day behaviour and the attainment of goals. Many factors like, physical, socio-economic conditions and culture, influence the health of children. School education plays an important role in promoting sound health among children by involving them in various physical activities, such as, games, sports and yoga. These activities foster development of physical, socio-emotional competencies, and academic performance among students. All the policy documents have very categorically focused on the role of schools in holistic development of children in all age groups.

The National Council of Educational Research and Training (NCERT) has developed a textbook on Health and Physical Education for Class XI. This book focuses on a holistic understanding of health and physical education, different individual and team games, yoga and its relevance in modern times and safety and security. Fitness development and fitness measurement tests, types of tournaments and competitions being organised at various levels are also covered in this book. Given the inter-related nature of the concepts covered in the area of health and physical education, efforts have been made to present the content in a cohesive and integrated manner. Experiential learning activities for acquiring skills in games, sports and yoga for healthy living have also been made an integral part of the book.

NCERT appreciates the hard work done by the Textbook Development Committee. Professor Saroj Yadav, *Dean (Academic)* has made continuous efforts to develop this book. Several experts and teachers have also contributed towards the finalisation of this book. We are grateful to them for their contribution. As an organisation committed to systemic reform and continuous improvement in the quality of our products, NCERT welcomes comments and suggestions which will enable us to undertake further revision in the book.

New Delhi
October, 2019

HRUSHIKESH SENAPATY
Director
National Council of Educational
Research and Training

© NCERT
not to be republished

TEXTBOOK DEVELOPMENT COMMITTEE

MEMBERS

- Archana Chahal, *Professor*, Department of Physical Education, University of Allahabad, Prayagraj, Uttar Pradesh.
- Bhuwan Chandra Kapri, *Professor*, Department of Physical Education, Banaras Hindu University, Varanasi, Uttar Pradesh.
- Ikram Hussain, *Professor*, Department of Physical Education, Aligarh Muslim University, Aligarh, Uttar Pradesh.
- Ishwar V. Basavaraddy, *Director*, Morarji Desai National Institute of Yoga, Ministry of Ayush, Government of India, New Delhi.
- Nishant Singh Deol, *Professor*, Department of Physical Education, Punjab University, Patiala.
- Poonam Khattar, *Professor and Head*, Department of Communication, National Institute of Health and Welfare.
- Priyanka, *Assistant Professor*, Mihir Bhoj PG College, Dadri, Gautam Budh Nagar, Uttar Pradesh.
- Ratnesh Singh, *Associate Professor*, Department of Physical Education, Guru Ghasidas Central University, Koni, Bilaspur, Chhattisgarh.
- Shorya Kumar Yadav, *Professor*, Department of Physical Education, Devi Ahilyabai University, Indore, Madhya Pradesh.

REVIEW COMMITTEE

- Anuradha, *Teacher*, Sardar Patel Vidyalaya, New Delhi.
- Arun Kumar Uppal, *Former Dean*, Laxmibai National Institute of Physical Education, Gwalior, Madhya Pradesh.
- Atul Mittal, *Dean*, Technical Support Unit, Ministry of Health and Family Welfare, New Delhi.
- Sanjeev Sharma, *Dean*, G.S.U. Rohini, New Delhi.
- Shorye Kumar, *Dean*, Department of Physical Education, Devi Ahilya Vishwavidyalaya, Indore.
- Vandana Nair, *Dean*, Technical Support Unit, Ministry of Health and Family Welfare, New Delhi.

MEMBER COORDINATOR

- Saroj Yadav, *Dean (Academic)*, NCERT, New Delhi.

ACKNOWLEDGEMENTS

The National Council of Educational Research and Training (NCERT) acknowledges the valuable contribution of the following individuals and organisations involved in the development of this book. The council acknowledges the contribution of the following academics for reviewing and refining the manuscript of this book: Amit Sharma, *TGT*, Physical Education, Kendriya Vidyalaya No.-1, Delhi Cantt.; Ashwani Bhati, Demonstration Multipurpose School (DMS), Regional Institute of Education (RIE) Ajmer; Atul Dubey, *Former Principal*, NDV BPED College, Bhilwara; Bijaya Kumar Malik, *Associate Professor*, NCERT, New Delhi; Deepak Lakhera, *TGT*, Physical Education, DMS, RIE Bhopal; Mahendra Barua, *TGT*, Physical Education, DMS, RIE Bhopal; Guru Dutt Ghai, *Professor*, Department of Health and Physical Education, Laxmibai Institute of Physical Education, Gwalior, Madhya Pradesh; Harish Kumar Meena, *Assistant Professor*, NCERT, New Delhi; Indu Sharma, *Assistant Professor*, Yoga, Morarji Desai National Institute of Yoga, New Delhi; J.L. Pandey, (*Retd.*), NCERT, Kamlesh Soni, *PGT*, DMS, RIE, Bhubaneswar, Odisha; Kusum Yadav, *Principal*, Rao Birender Singh College of Education, Rewari, Haryana; Mehar Chand, *Physical Education Teacher*, Jawahar Navodaya Vidyalaya, Patan, District-Sikar, Rajasthan; Neetu Sharma, *Yoga Therapist*, Morarji Desai National Institute of Yoga, New Delhi; Parmod Kumar Sethi, *Assistant Professor*, Physical Education, P.G.D.A.V. College, University of Delhi; Preeti Shukla, *TGT Physical Education*, Kendriya Vidyalaya, Tagore Garden; Priti Verma, *TGT*, Physical Education, Kendriya Vidyalaya, Shivgarh, Raibareli, Uttar Pradesh; Pushkar Vohra, *Joint Secretary*, Central Board of Secondary Education; Rajveer Singh, *Physical Education Teacher*, Jawahar Navodaya Vidyalaya, Baghra, Muzaffarnagar, Uttar Pradesh; and Vikram Singh, *Professor*, Department of Physical Education and Sports, Sports Complex, JNU, New Delhi.

We acknowledge the contribution of Aakansha, *Junior Project Fellow*, NCERT, New Delhi for going through the material, Rani Sharma (*PA*) for creating a CRC, Ravi Sharma, Ruby Malik for typing the material and Bittoo *DTP Operator* whose continuous support helped in putting the draft and final document together. The contribution of Soumma Chandra, *Assistant Editor* (Contractual), Nitin Kumar Gupta, *DTP Operator* (Contractual), Publication Division, NCERT, are also acknowledged.

The Council gratefully acknowledges the valuable suggestions and feedback received during the try-out by teachers.

HOW TO USE THIS BOOK

This book for Class XI is an effort to place the required material at one place necessary for the transaction of this area. It is expected that the transaction of this subject area will enable the teachers and students to transform theoretical knowledge into action. Further the teachers will be empowered to bring out positive changes through modification during learning and practicing various games and sports among students. In schools where infrastructural facilities are not available, the teacher may improvise them with the help of students like playground, equipment, rules of the games, etc. This will also develop creativity among children. Playing games and sports of all kinds are important for holistic health.

The overall objective of this area is to make games and sports joyful and thereby making children physically fit, mentally alert, and emotionally strong. The teacher may also encourage them to select game or sports of their choice. Yogic practices need to be considered as an integral part of their everyday life.

While transacting this area, the teacher should also emphasise on developing life skills, such as, understanding self and social awareness, team building, cooperation, empathy, communication skill, creative thinking, and also development of values.

Efforts have been made to include latest rules and regulations of various games, sports, and other related areas. Since rules and regulations keep on changing, teachers and students may visit the official website of recognised federation or association of different games and sports. The names of some websites are given separately. The teachers and students may also see some of the videos of different games and sports given on the websites for better understanding the rules and learning the skills.

The students can correlate the given activities in the textbook with their day-to-day life.

As a teacher, you have to understand that this textbook is different from other subject textbooks in the sense that its contents need to be understood well and applied throughout life for one's own well-being and that of others. Its use should not, therefore, be solely examination driven. Even a general discussion from time to time would be useful. Activities included in it, are of practical nature, and enjoyable and one can make sure that the concepts are clarified by involving students in experiential learning. Physical activities and exercises of all kinds have been given to ensure the development of fitness and questioning skills, including life skills.

We would welcome your feedback on this book in terms of — How did you like this textbook? What are your experiences in organising or being a part of various activities? What were the difficulties faced by you? What changes would you like to see in the next version of this book? Do write to us on all these and all other matters related to this textbook. You could be a parent, a teacher, a student or just a casual reader. You can send your feedback in the form given at the end of this book to the undersigned.

We sincerely hope you enjoy this book and learn more than it offers.

SAROJ YADAV
Professor and Dean (Academic)
National Council of Education
Research and Training

CONTENTS

	<i>Foreword</i>	<i>iii</i>
	<i>How to use this book</i>	<i>vii</i>
Chapter 1	Physical Education	1 - 14
Chapter 2	Understanding Health.....	15 - 31
Chapter 3	Physical and Physiological Aspects of Physical Education and Sports.....	32 - 48
Chapter 4	Individual Games.....	49 - 128
Chapter 5	Team Games.....	129 - 209
Chapter 6	Yoga and its Relevance in the Modern Times	210 - 250
Chapter 7	Safety and Security.....	251 - 271
Chapter 8	Health Related Physical Fitness	272 - 287
Chapter 9	Measurement and Evaluation	288 - 299
Chapter 10	Tournaments and Competitions	300 - 327
Chapter 11	Adventure Sports	328 - 336
	<i>Feedback Questionnaire</i>	<i>337 - 338</i>

LIST OF USEFUL WEBSITES

Note: Please refer to the websites of the recognised federations of the various sports for updated information about the rules and regulations.

- www.ioc.org
- www.arisf.sports
- www.iaaf.org (Athletics)
- www.BWFBadminton.org (Badminton)
- www.fiba.basketball (Basketball)
- www.fifa.com (Football)
- www.gymnastics.sports (Gymnastics)
- www.IHF.info (Handball)
- www.Fih.ch (Hockey)
- www.ijf.org (Judo)
- www.fina.org (Swimming)
- www.ittf.com (Table Tennis)
- www.itftennis.com (Tennis)
- www.fivb.com (Volleyball)
- www.unitedworldwrestling.org (Wrestling)

Note: For updation of every game and sport, you can consult or refer to rule books of various sport's federations.



11152CH01

PHYSICAL EDUCATION

1

In modern times, Physical Education is one of the most exciting and dynamic subjects. This subject has changed dramatically during the last 50 years. It has expanded in different areas from school to non-school setting and from school-aged children to people of all ages. Earlier, physical education was generally understood as physical activities either in school time table or some free hand exercises, games, sports, racing, swimming, etc. If we look at the Indian history of physical education after Independence, a number of schemes were launched by the Government of India for schools, where every student must participate in physical activities. We can witness the growing interest in games and sports exemplified by the fitness boom and the wellness movement. Sports events receive worldwide coverage. In schools, students like sports and other forms of physical activities, which help to achieve and maintain their health and well-being.

Do You Know?

- *Sharir Madhyam Khalu Dharma Sadhnam* means physique is the prime source of performing all duties.
- Swami Vivekananda and other philosophers like Socrates, Aristotle, and Plato were of the opinion that physical training was necessary for the youth.

MEANING AND DEFINITION

Physical Education is an education which brings improvement in human performance with the help of physical activities. Physical activities range from simple walking to jogging, running, sprinting, hopping, jumping, climbing, throwing, pushing, pulling, kicking, etc. Education without physical activities is like body without soul. There is no controversy in giving due place to physical education and different forms of exercises in the total set-up of education. All teachings in human education begin with physical education. Physical education is also considered as movement education as the life begins from movement only. In general life is characterised by movement. The movement starts from the birth of a child, till the end of life.

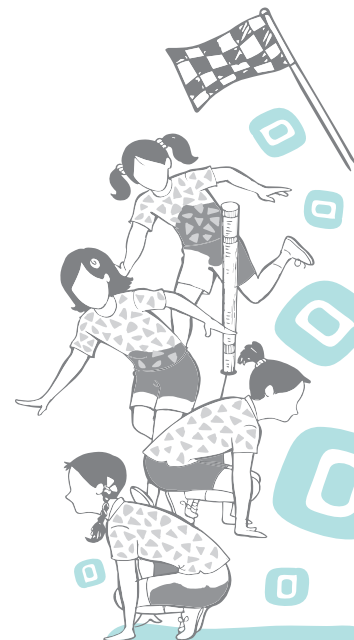

Mental, intellectual, emotional and social development of a growing child is dependent and closely related to physical development. A physically fit individual possesses a well-balanced personality which is, mentally sharp, emotionally stable and socially well-adjusted.

Physical education teaches how to acquire ability to develop strength, speed, endurance and coordination abilities. It also emphasises on achieving social qualities, such as, empathy, cooperation, friendliness, team spirit, and respect for rules, which are essential for healthy social relations with others. In this era of technological advancement, physical education and sports are considered essential for health, fitness, wellness, vigour and strength.

The concept of physical education is not new. The fact is that it has its roots in the ancient period. At various stages in history, different people have associated different meanings to the word 'Physical Education'. Physical Education in simple words is understood as learning with the help of movements of body and realising the benefits at mental level. It simply means education through the use of physique and physical movements and deriving the advantage for social gain. Some of the definitions given by well known authors are given here to understand and for the ready reference of the students.



Fig. 1.1: Children participating in physical activities and exercise

Definitions of Physical Education

In ancient India, a sanskrit adage stated that “*Sharir Servarth Sambhavo Dehe*”. The National plan of physical

education (1956) states that, “Physical education should aim at making the child physically, mentally and emotionally fit and developing personal and social qualities which will help to live happily with others and build a good citizen”. It further emphasises that the development of the total personality and achievement of worthy citizenship motivated for service should be the outcomes of physical education.

According to the Ministry of Education and National Planning for Physical Education and Recreation, “The aim of physical education must be to make every child physically, mentally and emotionally fit and also to develop in him personal and social qualities that will help to live happily with others. Physical education programme should also aim to build good citizens of the country.”

According to the Central Advisory Board of Physical Education and Recreation, “Physical education is the process of education through physical activities. It is the development of the total personality of the child to its fullness and perfection in body, mind and spirit.”

Sports and physical education are an integral part of the learning process, and need to be included in the evaluation of performance. A nation-wide infrastructure for physical education, sports and games are required in the educational field. The infrastructure consists of playfields, equipments, coaches and teachers of physical education. Available open spaces in urban areas can be used for playgrounds. Efforts should be made to establish sports institutions and hostels where specialised attention can be given to sports activities and sports-related studies, along with normal education. Appropriate encouragement should be given to those who have talent in sports and games. Due focus should be given on indigenous traditional games.

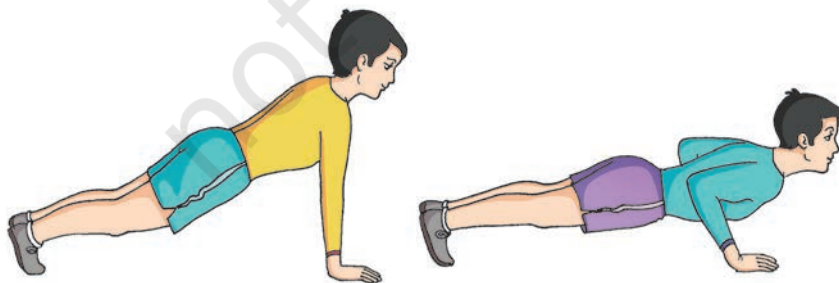
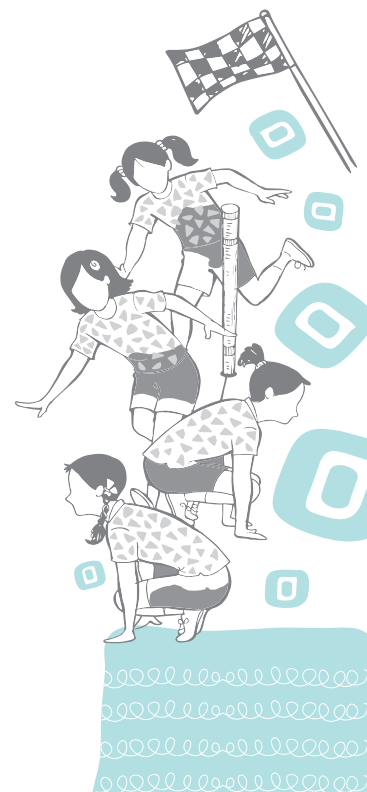

Fig. 1.2: Physical exercise



Activity 1.1

- Prepare a chart on the steps taken by the Government of India to promote games and sports in India and discuss with your classmates.
- Prepare a chart on the Importance of Physical Activities on health and discuss in the class.
- Discuss Fit India Movements and its benefits.

Charles A. Bucher has defined Physical Education as an “Integral part of total educational process, is a field of endeavour which has its aim — the development of physically, mentally, emotionally and socially fit citizens through the medium of physical activities which have been selected with a view to realise these outcomes.”

According to American Alliance for health, physical education, recreation and dance, “Physical Education is education through physical activities which are selected and carried as with regard to value in human growth, development and behaviour”.

Finally, it can be concluded that the development of all personality traits like, physical, social, mental, emotional, and moral takes place through various programmes of physical education.

AIMS AND OBJECTIVES

If you are doing physical exercises or playing any game regularly, you must have realised their importance. The aim of physical education is to target the total development of human personality. In physical education, the final aim is to make every human being physically, mentally and emotionally fit and also to provide each kind of opportunity to them, so that they can develop such personal and social qualities which will help them to live happily with others and shape themselves as true citizens of the country.

Efforts are needed to provide adequate facilities and ample time for the individuals and the groups to participate in situations that are physically wholesome, mentally stimulating and socially sound. Through physical education one can strive to achieve the following aims and objectives.

Motor Development

The objective of motor development refers to the neuromuscular relationship of nerve or nerve fibre to the one that connects the central nervous system with muscles. This in turn enables the movement of the body. To enhance the ability of the body to act, react and interact, it is necessary to exercise the muscles and nerves. In other words, physical development of a person is the foremost objective of physical education. Physical education is related to physical activities, which when performed, have an effect on various organ systems of our body. It leads to the improvement in size, shape, efficiency, etc., of various organs of these systems. An individual who is having good motor movements may perform daily routine work very effectively without undue



fatigue and laziness and feels confident in life. It also promotes sound health which enables an individual to become a valuable asset for the society and nation.



Fig. 1.3: Children participating in physical activities and exercise

Motor development can be possible through participating in different kinds of physical activity programmes like, games, sports, yoga, dance, etc.

Mental Development

Mental development refers to the ability to think and solve problems effectively. Knowledge received by participating in physical activities about body movement, health, fitness, sanitation, nutrition, disease prevention and others may contribute to an individual's mental development. A mentally developed person takes wise decisions at the right time and in a right spirit. Mental development objectives deal with a person's ability to think correctly, act wisely and skillfully in all situations of life. Various activities conducted in physical education classes not only require physical strength but also need mental alertness, deep concentration, and precise movements. In this manner, physical education also sharpens the mind and makes it more efficient.

Emotional Development

This refers to a psychological situation of body and mind. Emotion is a drive to do something. Emotion covers

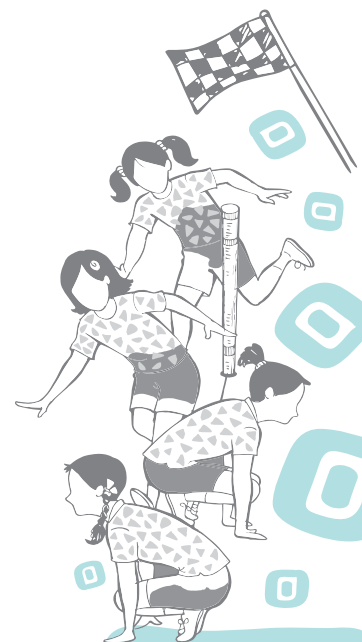

Activity 1.2

Prepare a project on the status of various facilities available in your district related to various games and sports. Critically analyse how these can be shared effectively.

experiences, such as, fear, anger, joy, love, sorrow, etc. It is usually a feeling which has specially become intense. For example, joy means intense pleasure. A child needs to develop confidence, a feeling of belongingness, and eliminate negative feelings through participating in games, sports, yoga, etc.

Social Development

This objective of physical education refers to the feeling of belongingness, adjustment of group living, social poise, social relationships, and social adjustment. Physical activities provide such opportunities to the children to fulfil basic needs like, recognition, self-respect, belongingness, and love. When these needs are fulfilled, the individual becomes a well-adjusted social person. While participating in physical activities including games and sports, an individual acquires social qualities, such as, cooperation, friendship, courtesy, empathy, team spirit, democratic living, sportsmanship, etc. These qualities are essential for social development.

Moral Development

Every game has a set of rules and regulations and it is the duty of each player to obey them. The players know that disobedience of any rule is a moral crime that can result in their expulsion from the team. Therefore, obedience of these rules becomes the moral duty of each player. Participation in games helps in moral development and equips them to differentiate between right and wrong with honesty. Hence, physical education also plays an important role in the moral development of a person.

NEED AND IMPORTANCE OF PHYSICAL EDUCATION IN THE MODERN SOCIETY

The modern researches have proven that the views of Greek philosophers Aristotle and Socrates in considering athletics as complete education is correct. It has been scientifically observed that adequate exercise of limbs is essential for disciplining one's mind in the right spirit. Regular exercises and playing games help the body and mind to deal with the modern day silent killers, such as, stress, strain, worry, anxiety and tension. The need and importance of physical education may be understood in several ways which describes the different kinds of requirements for various sections of the society.

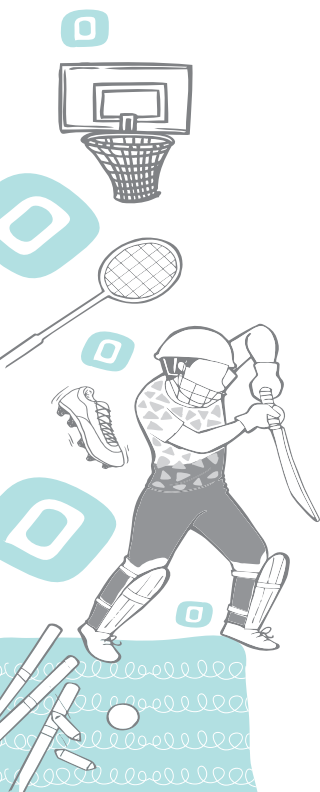

Health and Physical Education must continue to be a compulsory subject from the primary, to the secondary stages, and as an optional subject at the higher secondary stage. However, it needs to be given equal status with other subjects, a status that is not being given at present. In order to transact the curriculum effectively, it is essential to ensure that the minimum essential physical space and equipment are available in every school, and that doctors and medical personnel visit school regularly.

It should be possible to organise the utilisation of school space, at the block level at least, for special sports programmes both before school hours and after school hours to enable children with special talents for sports to come here for special training and during vacation periods. It should also be possible to develop these sports facilities so that many more children can avail of these for leisure-time sports activities and engage with team games such as basketball, throwball, volleyball, and local forms of sports.

Source: The National Curriculum Framework 2005

The need and importance of physical education for every section of people in the modern society can be understood from the points given below—

- Optimum development of child's physical growth
- Intellectual development
- Emotional development
- Social development
- Personal development
- Character building
- Physical fitness
- Development as a disciplined citizen of the country
- Neuromuscular development
- Cultural development
- Developing leadership qualities
- Healthy and safe environment
- Development of national integration
- Better international understanding

Sports and games play an important role in the development of human personality. They are no less important than food and fresh water. It is interesting to note that there are many nurseries and training centres for games in most of the developed countries.

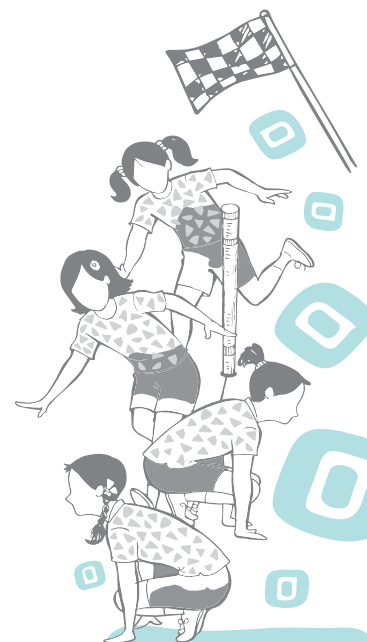

Activity 1.3

- Prepare a list of common myths prevailing in your surroundings by discussing with your parents, grandparents, and other community members.
- Compare with list given.
- Discuss with your classmates “How to remove these myths?”

MISCONCEPTIONS ABOUT PHYSICAL EDUCATION AND SPORTS

Lack of understanding about the importance of physical education results into misconceptions and disbelief.

There are a number of misconceptions related to physical education. Some people do not agree that it is a part of the educational process. The fact is that, skill, fitness, performance, and health are parts of physical education. It addresses the educational and developmental values that are the results of participation in physical activities. The participation in these activities develops social or co-operative attitude, good character and a balanced personality. However, when one fails to recognise this holistic approach of physical education, it results in a number of misconceptions. People in the society are either less aware about the advantages of taking part in physical education activities or are left behind with the pace of modern educational system. Thus, it becomes important for all of us to understand what we think and how the modern world is looked at by educated and disciplined people of the society. Some of the common myths associated with physical education are given below.

Physical Education

- is all about physical training only.
- is only about the participation in games.
- is about building body.
- is performing drill.
- is play.
- has poor social status.
- has no job or career prospects.
- leads to indiscipline.
- is wastage of money only.
- has rest periods hence, no physical or mental earning.
- is taken-up by left out group only.

TERMINOLOGY USED IN PHYSICAL EDUCATION

Game

It is often considered as an activity played by more than two people combined as a team. There are defined objective, time, space, rules, and limited pattern of behaviour, the outcome of which is to determine a winner or loser.



Fig. 1.4: Children playing football

Sport

Sport is a wider term which acts as an institution involving all physical activities, individual skills, governed by a set of rules and often taken competitively.

Sports Training

Planned and systematic process of preparation of sports person or athlete for better performance, which is based on scientific principles, is called sports training. It improves specific fitness and sports specific skills, techniques, and tactics.

Gymnastics

Gymnastics include different exercises, without apparatus, and with apparatus. These exercises involve arm, leg, hand and trunk movements as well as performing jumping movements, and maintaining balance. It constitutes agility exercises done on various kinds of gymnastic apparatus like, parallel bars, horizontal bar, beam, pommel horse, ring, etc.



Fig. 1.5: Players performing gymnastics

Physical Culture

In some of the countries, physical education is considered as 'physical culture'. The culture is synonymous to our social belief, custom, and religious way of treating the body as temple. It also includes the concept of making the body beautiful by developing shaped muscles. Weight-training devices, and sharp and high intensity exercises are some of the means, used for muscle training so that the body looks muscular and in good shape.

Drill

Drill includes different kind of body exercises for developing good posture of standing, walking, fighting, etc., and

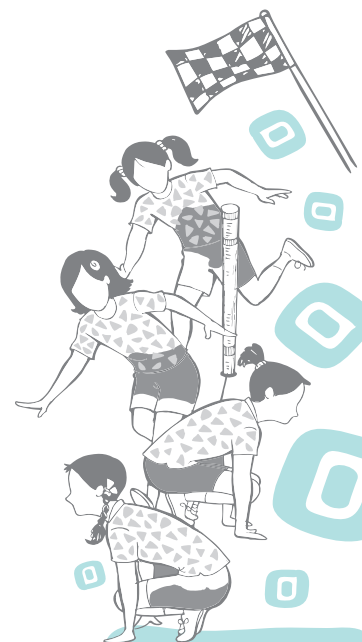

disciplining the body and mind. In games and sports, drill is the process of repetition of activities done with beats, music, or verbal order.

Health Education

Health Education includes the knowledge about diseases, health, rest, sleep, sanitation, pollution and psychosomatic disorder. A healthy person is an asset for the society whereas an unhealthy person is a liability.

Recreation

Recreation includes playing, singing, camping, hiking, reading, gardening, dancing, and many more pleasure-giving activities. Through recreation one can regain the lost energy, vigour, and spirit. After hard work one can engage in different kinds of recreational activities for releasing mental stress and get rid of fatigue.

CAREER OPTIONS IN PHYSICAL EDUCATION, SPORTS AND ALLIED AREAS

There are many job opportunities and open career options with broader choices in Physical Education. A sports career in India, which was considered less lucrative in the past, has now become one of the options for students. Sometimes the students take interest in this profession merely for adventure and a tension free life. Individuals, who demonstrate peak performance in sports and physical education, follow a set of mental processes that allow them to produce excellent results consistently. These performance strategies translate into a specific set of mental skills. By learning these skills, effectiveness and performance can be enhanced. There are key strategies that lead to high performance in the field of sports—through the training of mental practices, individuals can accelerate their development and improve their performance. Self confidence is one important key to success. For example, physical education programme helps to boost one's self confidence. To make a career in physical education, one should start by setting modest goals that are meaningful but attainable. Some of the options given here are broad areas that are often selected by the students undergoing various physical education courses as a choice with higher success rate.

Teaching or Coaching

Career in sports has been mainly focused on teaching and coaching in schools, colleges, and universities. Teachers are involved in teaching and organising physical activity



programmes based on theory and practical syllabi of health and physical education, extramural and preparation of teams. Coaches are potentially sportspersons or players with talent in fundamentals, techniques, and rules of competitive sports or games. Coaches are responsible for overall preparation, and performance of teams. Coaches are also employed in government run centres, sporting clubs, holiday resorts, etc., for special sports. Some may also be self-employed in their own sports training centres.

Health, Sports and other Related Careers

Nowadays, the interest of youth in health and particularly fitness has been increasing. The demands for specialists therefore, in health-related career have also increased. The major career categories in health are—

Physical fitness instructor

These are better known as gym or aerobics instructors. They supervise people in games, fitness clubs, sports centre, health clubs, etc. They prepare the routine of exercise according to age, gender and level of fitness of the person. Instructors make sure that the equipment are correctly set up. They work in consultation with the dieticians, physiologists, psychologists, doctors, etc.

Dietician

They plan the diet for a player or a team so that they eat proper and balanced food according to their physical work. In the present time, dieticians are considered important part of modern spa, and beauty parlours and also in hospitals and health centres.

Sports Medicine Physician

The sports related injuries are different in nature. Sport Medicine Physician can give better treatment to sportsperson after understanding the seriousness of sports related injuries. A good sportsperson can become a better physician. It is the duty of the sports medicine physician to cure the sportsperson so as to enable him/her to come back in the mainstream. There is thus, a tremendous scope for this sports career.

Sports Administration Related Careers

An administrator in sports can be a Sports Director, Sports Officer, Head of Department, General Manager, Executive Director, Supervisor, etc. The areas that they take care of are related to finance, scheduling equipment, facilities, public relations, and many more. They also undertake the

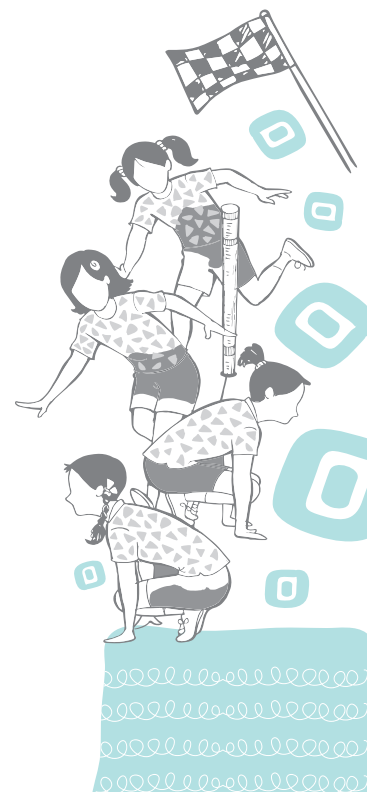

Activity 1.4

Collect some more information about careers in Health and Physical Education.

responsibility of implementing curriculum, monitoring staff, office, managing sports information, scholarship and promotion, supervision of coaches and various competitions, organising conferences, etc. An administrator must have leadership qualities, should be well organised, willing to accept responsibilities, hard working and honest.

Performance Related Careers

Performance related careers in sports are of two types, one is professional performers in sports, and second is sports officials. The sports performers play as an individual or in team for organisations on contract or on pay-roll basis either for a specified period, or otherwise. Sports officials like, referee, umpire, judges, etc., officiate the match or tournament on contract or on pay-roll basis either for a specified period or otherwise. Every sportsperson wants to be a professional performer but only a few succeed in earning a living. The dream of every sports person is to be a professional performer like Dhyan Chand, Milkha Singh, Sachin Tendulkar, Mary Kom, Vishwanathan Anand, Mahesh Bhupati, Sakshi Malik, etc. For officiating, no educational qualification or degree is required, only a written and practical examination conducted by the state and national sport organisation of a specific sport has to be cleared.

Communication Related Careers

A wide range of career opportunities are available in sports communication as variety in the means and methods of communication are the demands of the society. Sports communication includes sports writer, sports editor, sports publisher, sports photographer, painter/artist, broadcaster, sports information director, sports statisticians, etc.

Sports Writers

There is a separate section devoted to sports in all the newspapers, magazines, periodicals, bulletins, etc. For writing these sections, sports writers are required. The job of sports writer is to cover the stories related to the vast world of sports on the basis of performance, team selection, policies, management, results, and other related matters to write sports column.

Sports Publishers

Sports Publishers are responsible for all the publication units including the quality, content, sales and promotion of books, etc. As there are various textbooks, coaching



books, sports magazines, audio-visual material, journals, periodicals, etc., so publication also has reputed value as a career in sports.

Photography

As the scope of photography in sports is not very vast, people may opt for it as a part-time/full-time career in sports. Individuals with artistic ability, skill and experience in painting and drawing sports events can choose this profession.

T.V. or Radio Reporters

Sports are a valuable section on broadcast and telecast. Sports events are broadcasted and telecasted to be heard on every radio-station and can be seen on T.V. channels respectively. Because of high demands of sports, provision of special T.V. sports channels are there. The duties of broadcasters are to present sports programmes on T.V. or radio live from the stadium or playfield. They also present commentary summaries, reviews and sports news on T.V. and radio. Sometimes they anchor special sports programmes, do interactions or take interviews of sports personalities.

Sales and Management Related Careers

This profession includes sports marketing executives, sports events managers and sports competition organisation associated with sports equipment, material, etc. The ability to interact with customers and to convince them that the product or event is suitable to their needs, is the base for becoming a successful sports manager. Knowledge of the product and organisation of various types of tournament and championship are pre-requisite for these jobs. This job involves high responsibility and alertness, so long hours in the service are required.

Physical education also helps in opting for other careers such as defence, para-force, and police service, etc.

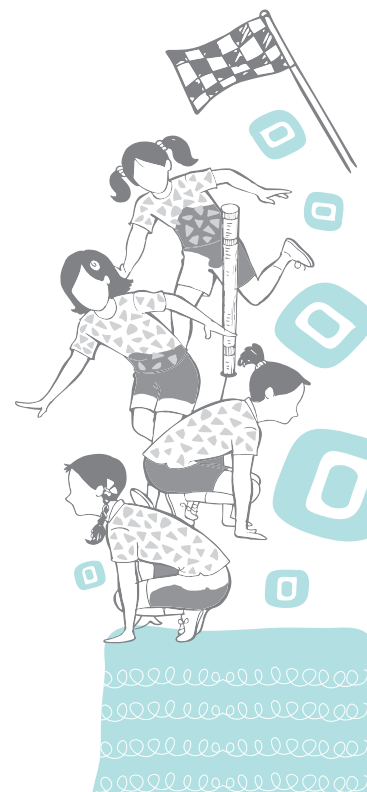

ASSESSMENT

I. Long Answer Questions

1. Define physical education and discuss the importance of physical education in daily life.
2. What are the main objectives of physical education? Explain any four in detail.
3. What are the misconceptions about physical education and sports?
4. What are the career options in physical education?

II. Short Answer Questions

1. Define recreation.
2. What do you understand by the term 'Drill'?
3. Write the names of apparatus used in Gymnastics.
4. What are the differences between games and sports?

III. Fill in the Blanks

1. Games include different teams where the number of players is _____.
2. In some of the countries physical education is considered as _____.
3. After hardwork, one can engage in any kind of _____ activities for releasing mental stress and get rid of fatigue.
4. Drill includes different kinds of body _____ for developing good posture of standing, walking and fighting, etc.

IV. State whether True or False

1. The concept of physical education is new.
2. In modern times Physical Education is one of the most exciting and dynamic subjects in its history.
3. Charles A. Bucher has defined Physical Education as an "Integral part of total educational process".
4. Gymnastics includes different exercises, without apparatus and with apparatus.
5. Physical education does not promote emotional development of a person.





11152CH02

UNDERSTANDING HEALTH

2



Health is commonly understood as a state of absence of disease. This definition of health is focused only on the ability of the body to function, that may be disrupted from time to time by diseases. However, this definition of health is partial and covers only the physical aspect. In this perspective, the meaning of health has been changing over a period of time. In 1948, the World Health Organization (WHO) defined it comprehensively as “a state of complete physical, mental and social well-being and not merely the absence of disease or infirmity.” Health is now referred to as a state of physical, mental, intellectual, emotional and social health and well-being. It is the ability to adapt and manage physical, mental and social challenges throughout life. Moreover, it is also the ability of a person to handle stress, acquire skills, and maintain positive relationships. It is widely acknowledged that health is influenced by biological, socio-cultural, economic, and environmental forces. Access to basic needs like, food, safe drinking water supply, housing, sanitation, health services and availability of positive socio-cultural, economic, and environmental settings influence the health status of a population.

HEALTH AND ITS DIMENSIONS

Health, indicates a sound body and a sound mind. It is multidimensional—the dimensions being physical, mental, emotional, social, spiritual and environmental. All these dimensions are interrelated with one another.

Physical Dimension

Physical dimension refers to the ability of a human body to function properly. It involves exercises, healthy habits, balanced diet, bone health, and body mass index. We

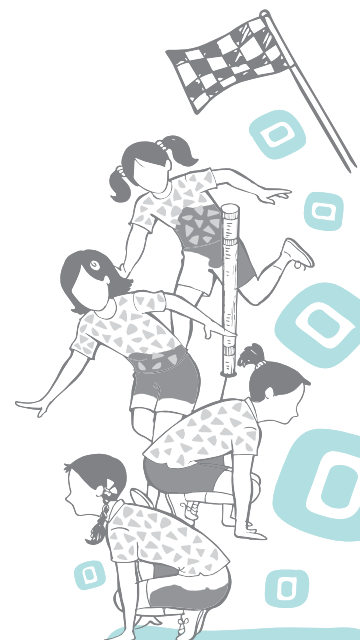

can maintain a healthy body by taking proper nutrition, exercising, and avoiding harmful habits such as substance abuse. It is better to consume nutritious foods and beverages that enhance good health rather than those which impair it. Physical wellness is the ability to maintain the quality of life that allows one to get through daily activities without undue fatigue or physical stress. Optimal physical health consists of building physical strength, flexibility, coordinative ability, and endurance while taking safety precautions including medical self-care and appropriate use of a medical system, as well as protecting oneself from injuries and harm. It involves personal responsibility, disease prevention, and care for minor illnesses and also knowing when professional medical attention is needed. Being physically fit and feeling physically well often leads to the psychological benefits of enhanced self-esteem, self-control, determination and a sense of direction.

Mental Dimension

Mental health refers to the cognitive aspects of health that includes thinking, reasoning, remembering, imagining, and learning words. Cognitive aspect is related to the processes of perception, memory, judgment, and reasoning, as contrasted with emotional processes. It refers to the ability of individuals to use their brain and think, process information and act properly. It is our capacity to master new skills, embrace humour, and creativity. A sound mental health plays an important role in shaping our daily activities. It helps individuals in making a complete person. To stimulate our mental health, we can engage in various activities such as questioning critically, involving ourselves in creative, and problem solving activities. Mental health leads to an increase in self-esteem, and thereby leads to confidence in social situations. A sound mental health depends primarily on increased physical activities. Engaging in games and sports regularly keeps us mentally active.

How can we have good mental health?

- **Eat healthy food:** There are strong links between what we eat and how we feel. A 'healthy diet' is one that has enough essential nutrient, and provides the right amount of calories to maintain a healthy weight.
- **Express your feelings:** Whenever we are feeling stressed, then talking about our feelings helps us to stay in good mental health.



- **Play games and sports you like:** What do you love to play? Playing Hockey, Cricket, Chess or any other game or doing an activity you enjoy or you're good at, boosts your self-esteem. It helps you to concentrate, sleep, look, and feel better. Enjoying through games helps in beating stress also.
- **Get enough sleep:** Every day our body needs time to rest and heal. Sleep for about eight hours is must for all, especially for children.
- **Spend time with friends and family:** Friends and family can make you feel cared for. They can offer different views to your problems, and the tension you are feeling. This helps in better understanding of the problem or situation and thus in solving the problems.
- **Ask for help:** None of us is perfect in all aspects. We all have problems when things go wrong or get tired at times. If you feel that you cannot cope up with the situation, and things are getting too much, then do not hesitate to ask for help.
- **Do not consume tobacco products or alcohol:** Tobacco and alcohol result in illness in proportion to the consumption. Learn to say 'No' to your friends in such situations.

Social Dimension

This dimension of health refers to the ability of individuals to interact with others in the socio-cultural environment. A sound social health helps us in maintaining healthy relationships with others. Good social health includes not only having positive relationships but behaving appropriately and maintaining socially acceptable standards. It focuses on creating and maintaining healthy, and supportive relationships with family, neighborhood, friends, peers, teachers, and community members. Good communication skills help in establishing sound relationships. These relationships impact a person's life the most.

Social health also affects the other dimensions of health in many ways. A bad social life, many a times, lead individuals to question their purpose in life or feel isolated and unwanted. Such feelings can de-motivate individuals from physical activity and push them towards depression.

Emotional Dimension

Emotional dimension of health is another important ability to cope, adjust and adapt to our environment. People with

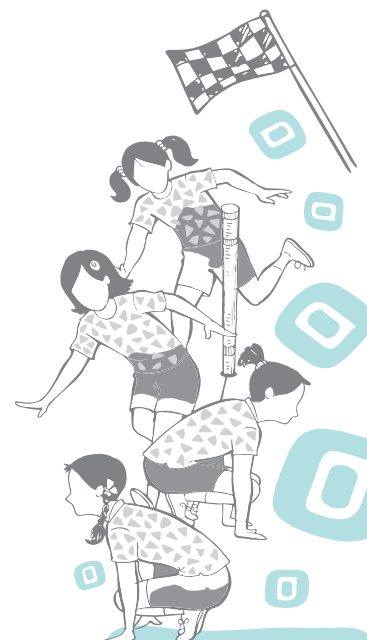

Activity 2.1

- List actions and activities to make 'greener' lifestyle, at home and at school.
- Review and find out how far you are able to achieve the objective of becoming 'greener'.
- Motivate others to adopt life style which promote greening the environment.

positive mindset tend to be more successful. It is a commonly used statement that 'individuals become the type of person like the friends they have'. It means that the friends and other people who live together in the immediate environment play a very important role in personality development and emotional wellness. Some of the techniques which help in having stable emotional health include: reading inspirational books, setting goals, learning how to deal with setbacks, acquiring characteristics such as hope, enthusiasm, and positive thinking.

Spiritual Dimension

There are different belief systems that exist all around the world. The spiritual beliefs will help the individuals discover and pursue their own value and belief and a sense of overall purpose in life. Generally, people often find their purpose from a belief or faith system while others create their own school of worship. A person who has a purpose in life is said to be healthier than those who do not have it.

Spiritual health easily affects emotional and mental health as having a purpose in life can help you to apply yourself to achieving goals. Having a purpose in life can also help people to maintain a proper perspective of life and overcome adversity. Often people who are spiritual, meet together regularly around their spiritual purpose, which helps to improve their social health also.

Environmental Dimension

Environmental health inspires us to live a lifestyle that is beneficial for our surroundings. It encourages us to live in harmony with the nature by taking action to protect it. Our environment consists of external and internal factors. Our surroundings such as our habitat, occupation, pollution levels at the places where we live and work constitute our external environment. A healthier planet leads to healthier inhabitants. The internal environment refers to an individual's internal structure in the form of genetic composition, which is very crucial in determining the health and wellness of human beings. Other environmental factors which include our family, friends, neighbourhood, community, habitat, all have an impact on our health.

The core principle of environmental wellness is respect for nature and all the species living in it. Environmental wellness does not mandate you to join a movement or organisation, but it does encourage you to practise habits that promote a healthy environment. When you become environmentally



aware, you will be able to realise how your daily habits affect the environment. Improving environmental wellness is simple and results in a more balanced lifestyle.

HEALTH NEEDS OF CHILDREN, ADOLESCENTS AND DIFFERENTLY ABLED

Health of the children is a critical concern for all societies, since it contributes to their overall development. The age group category of children includes toddlers, infants, and kids in the age-group up to 9 years, adolescents in the age-group from 10 to 19 years, and differently abled belonging to both the age-groups. Health, nutrition, and education are important for the overall development of the children, so that they grow as empowered members of the society and responsible citizens of the nation. The criticality of health concerns of all the groups need multi-dimensional response, depending upon their specific age, and socio-economic and educational status of the parents.

Health Needs of Children

Childhood is the stage during which the foundation of healthy life is laid. The physical, mental and social health needs are significant for the overall development of the child. The basic health needs of the children belonging to pre-natal, post-natal and childhood stages are related to food and nutrition, immunity, positive family and social environment. Children in India continue to lose their lives to vaccine preventable diseases, such as, measles, which remains the biggest killer. The major cause of mortality and morbidity among children is a group of disease conditions like, diarrhoea, pneumonia and fevers which occur due to lack of immediate treatment by the family and non-availability of adequate health services. Besides, poor living conditions and lack of response to basic needs of children are also responsible factors. Even those who survive these hurdles, by the time they reach school, they may be underweight, malnourished, and susceptible to multiple illnesses.

There is an urgent need to adopt a multi-pronged strategy to ensure adequate response to the health needs of children. Besides ensuring availability of quality health and nutrition services, reducing mortality rates, and improving access to education and skill development should be given priority. All children must undergo the entire course of vaccination and this process must continue. To attain these goals, it is essential to make the people aware about the urgent

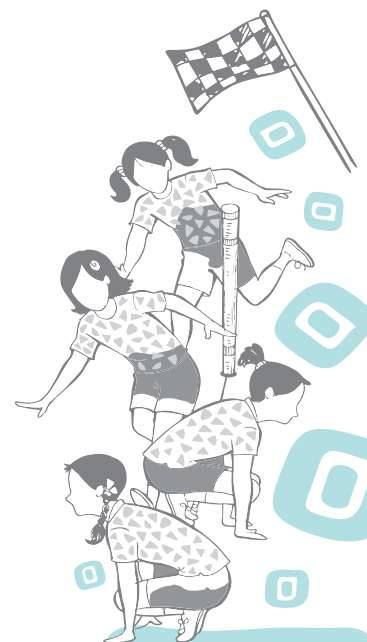

need of all the age-groups and ensure that these needs are responded well in time and health, and nutrition services are utilised. The process of governance must make sure that these services are availed by all including the marginalised sections of the society.

Health Needs of Adolescents

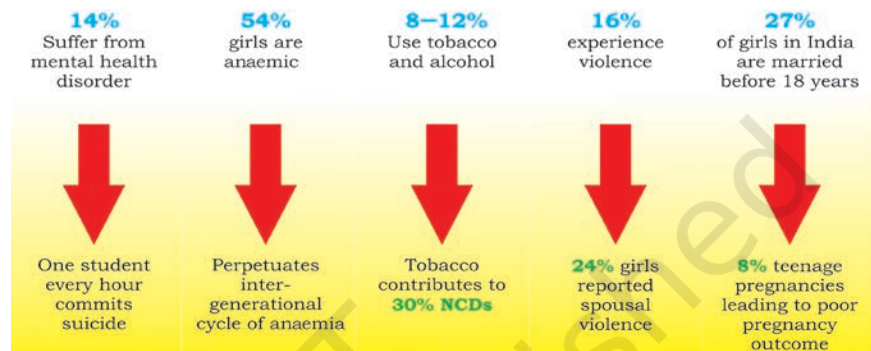

Fig. 2.1: Snapshot of adolescent health in India

Adolescents constitute about one-fifth of India's population. As you have already learnt, adolescence is a period of transition from childhood to adulthood and a critical period for the development of self-identity. The process of acquiring a sense of self-awareness is linked to physical, physiological, mental, and emotional changes. It is also a phase of learning to negotiate the social and psychological demands of being young adults. Responsible handling of issues like, independence, intimacy and peer group dependence are concerns that need to be recognised, and appropriate support be given to cope with them. Adolescents are confused about sudden changes taking place in their bodies and minds. As a result, they face many doubts regarding numerous concerns, and health related issues. Many adolescents experience tension, and stress and respond differently on different occasions.

There are concerns about growing too tall or not gaining height, growth and development of body parts, and so on. Worrying about pimples on the face is a common problem during adolescence.

Adolescence is also a time when there is a temptation to experiment, which leads them to indulge in various negative behaviours. The process of distancing from parents and dependence on peer group also lands them in confusing situations. No doubt the peer group provides positive impact but quite often it leads them to adopt negative behaviour. The most common is drug abuse. As a result, there are chances of their becoming addicted to smoking and various kinds of drugs. Initially, the young people take these for fun, relaxation, or



to get out of tension and stress. But later there are higher chances of one becoming addicted to these. Unfortunately, the earlier one gets into the habit of substance misuse, the greater are the chances of addiction, and serious diseases like cancer, and heart diseases during adult age.

Major health needs and problems among adolescents include nutritional disorders (malnutrition as well as obesity), substance abuse, high risk sexual behaviour, stress, mental disorders, and injuries (including road traffic injuries, suicides, and different types of violence). Many of these are precursors of communicable and non-communicable diseases (including mental disorders), and injuries, which inflict high morbidity, mortality, disability, and economic burden on adolescents, their households, and health systems. Moreover, the addiction to internet, especially to social media, has been increasingly keeping them under great stress, leading them to undergo depression and self-harm. They need help and guidance to pass over this period smoothly. They need counseling and healthcare advice, as well as treatment.

Health Needs of the Differently Abled

You would have observed that the differently-abled children are often hidden in their homes. Usually this type of discrimination starts in the family. It exists at various levels such as, education centers, work places, and in healthcare facilities and so on. Due to the stigma associated with disabilities, the families also become the victims of discrimination. As a result, the differently-abled children face chronic ill health, socio-economic burden, and isolation.

According to World Health Organisation, disability is an umbrella term, covering impairments, activity limitations, and participation restrictions. Disability is thus not just a health problem but is a complex phenomenon, reflecting the interaction between features of a person's body and features of the society in which they live.

The National Policy for Persons with Disabilities (2006) recognises that the persons with disabilities are valuable human resources for the country. It seeks to create an environment that provides equal opportunities, protection of their rights and full participation in society. The *2030 Agenda for Sustainable Development* has also highlighted about the needs and issues of 'Persons with disabilities' and 'Persons in vulnerable situation'.

Therefore, taking care of physical, social and emotional well-being of such a population is a major challenge. Many policies and welfare schemes have been planned in the

Activity 2.2

Discuss with your classmates —how and why excessive use of social networking site is depressing and self harming?

Do You Know?

About 2.21 per cent of the total population of India is 'disabled'. The highest number of disabled persons in India is from the State of Uttar Pradesh. At all India level, 7.62 per cent of the disabled persons belong to the age group of 0–6 years. Focus today is on inclusive education.

Source: Census 2011

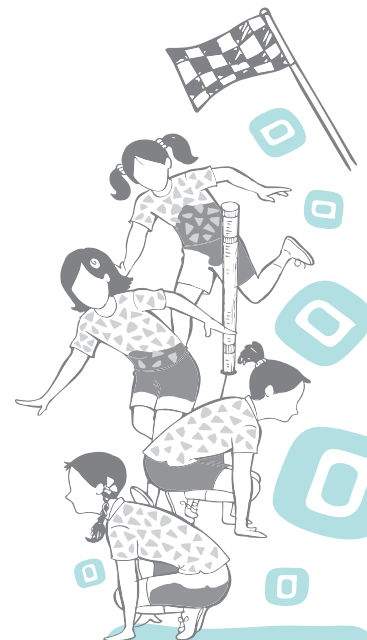

Activity 2.3

- Prepare a chart on the Disability Act 2016.
- Observe your surroundings and analyse how far the act has been implemented.
- List the actions you can take and share with your classmates.
- Collect information about various programmes and schemes for differently-abled individuals and share it in the morning assembly.

field of education and health to overcome various difficulties faced by the differently-abled individuals and their families. The focus is on 'inclusive development' for the welfare of differently-abled persons which is an important milestone towards sustainable development.

Health Status of Children in India at a Glance

- At all India level, the sex ratio in the age groups 0–6 years and 0–14 years are 918 and 916 respectively whereas it is 943 for all ages and also is not favourable to females in many of the States and UTs.
- As per Sample Registration System (SRS)-2016, there has been substantial reduction in the Infant Mortality Rate (IMR) at all India level from 46 in 2011 to 34 in 2016. Among the bigger States and UTs, IMR varies widely from 10 in Kerala to 47 in Madhya Pradesh. The IMR for female has been reported at 36 against 33 for male.
- Under-five Mortality Rate (U5MR) estimated at 39 for 2016 at all India level varies significantly in rural (43) and urban areas (Data). Among the bigger States and UTs, U5MR varies from 11 in Kerala to 55 in Madhya Pradesh.
- At all India level, 28 per cent of children had mild anaemia, 29 per cent had moderate anaemia, and 2 per cent had severe anaemia in 2015–16.
- National Family Health Survey (NFHS-4) (2015–16) shows that at all India level, 38 per cent of children under five years of age are stunted (too short height for their age) which is an improvement from 48 per cent in 2005–06. It is higher among children in rural areas (41%) than that of urban areas (31%).
- Five states with higher prevalence of stunting in children under five years age are Bihar (48%), Uttar Pradesh (46%), Jharkhand (45%), and Meghalaya (44%), whereas it is lowest in Kerala and Goa (20% in each).
- At all India level, 21 per cent of children under five years age are wasted. It varies in the range of 6 per cent in Mizoram to 29 per cent in Jharkhand.
- The prevalence of anaemia among children in age group 6–59 months is highest among children in Haryana (72%) and lowest in Mizoram (19%).
- At all India level, 62 per cent of children of age 12–23 months received all basic vaccinations at any time before the NFHS -4, and 54 per cent received all basic vaccinations by 12 months of age.



- National Crime Records Bureau (NCRB) data reveals that the rate of crime against children (below 18 years of age) has increased to 24 per lakh children in 2016 from 21.1 in 2015.
- Under Protection of Children from Sexual Offences Act, 2012 (POCSO) crimes reported are as high as 34.4 per cent of the total crime against children.

ADDRESSING THE HEALTH NEEDS OF CHILDREN

Institutions, teachers and reviewers play an important role in addressing the health needs of children. These are discussed below.

Role of Schools

Schools play a vital role in promoting the health and safety of young people and helping them to establish lifelong healthy behaviours. It is easier and more effective to develop healthy behaviours during childhood than trying to change unhealthy behaviours during adulthood. Many health risks behaviours are often established during childhood or adolescence and continued into adulthood. The following are the leading causes of diseases, death, disability, and social problems:

- Inadequate physical activity
- Unhealthy diet
- Substance misuse (Tobacco, alcohol and other drug use)
- Stress
- Behaviours that contribute to unintentional injury and violence
- Risky behaviours that can result in HIV infection, other sexually transmitted infections (STIs) and unintended pregnancy.

Regular physical education classes can help children to develop a healthy lifestyle.

Role of Teachers

Teachers have a very important role to play during the period spent in schools. They need to understand and address the diverse needs of their students through innovative teaching methods, counseling and referral to specialists wherever required. They need to work closely with the parents and community on sensitive issues and the emerging challenges being faced by the children. The teacher can plan various need-based health promotion programmes for the empowerment of children such as, engaging in games and sports, physical activities, curricular and extra-curricular activities, nutrition education programmes, and preventive measures for substance misuse.

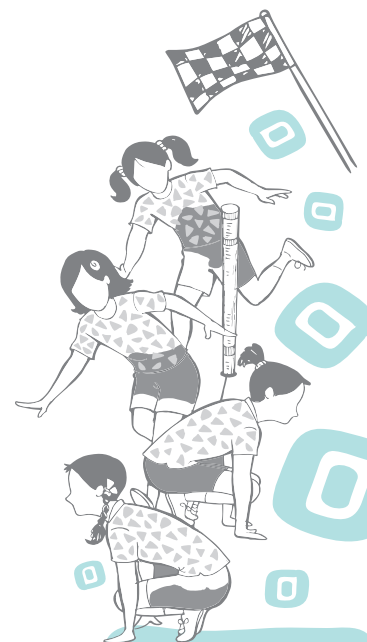

Role of Adolescent-friendly Health Services

The children during adolescence are usually considered a healthy cohort. They generally do not have any medical problem. They just want to have some more information or knowledge about some of the concerns that may be troubling their mind. Often they do not get any proper answer for their concern and get frustrated and feel lost. They can easily be misled, and hence get into wrong habits and adopt risky behaviours.

Adolescents are often quite reluctant to share many of their problems with parents, family members and teachers. They feel scared, ashamed or shy to discuss their problems with them since they believe that these people will get upset and will not be sensitive to their concerns. That is why, we need to encourage them to speak about their personal concern to someone whom they trust.

One of the emerging health needs of the adolescents is accessibility and availability of health services for various health issues. The healthcare workers can play an important role in making the services adolescent-friendly and encouraging them to use the health services more often. These services are provided by trained healthcare workers in adolescent-friendly health centres. These centers are being established by the government in the form of adolescent-friendly health clinics. The adolescents feel shy and are reluctant to use health services. Some of the reasons are lack of privacy or confidentiality, lack of patience and sensitivity among the health workers, and also lack of friendly behaviour from them.

Activity 2.4

Does your school provide training to be a peer facilitator? If not, please discuss it with your class teacher. Ask your school to take up the training of peer group educator/facilitator.

Role of Peer Educator or Peer Facilitator

Training or providing education to some adolescents who can help, educate or counsel other adolescents is emerging as a powerful technique for addressing the health needs of the adolescents. Such adolescents are called as 'Peer Group Facilitator/Educators'. They can help the adolescents to remove their shyness to talk to their parents, family members and teachers.

Training is given to the children of senior classes to understand and guide to the best of their ability to address the health needs of friends, peers, and other children in the community. But at the same time, one should be aware of one's limitations while giving information regarding sensitive issues and problems. Refer them to teachers or adolescent friendly services for appropriate support. As peer facilitator,

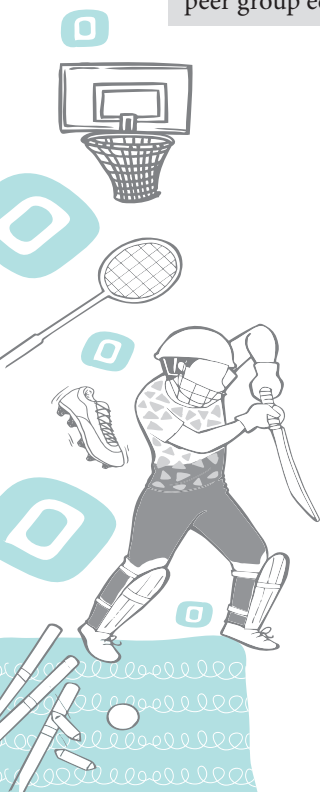

one can help the teacher in organising various activities related to adolescents' issues and concerns.

To be a peer group educator/facilitator, you should

- be a good listener.
- have knowledge about various health issues of the children during adolescence age.
- be friendly, influential and acceptable to adolescent children.
- be trusted and truthful.
- use creative and innovative approach while dealing with problems.
- be non-judgmental.
- practice confidentiality.
- be a good role model in the school and society.

Activity 2.5

You have read about lifestyle diseases in your previous classes. Can you list some of these? Also discuss about their prevention.

LIFESTYLE AND WELLNESS

Everyone wants to look good and healthy. Maintaining a healthy lifestyle requires commitment. Strong desire, dedication and motivation play an important role in accomplishing a healthy lifestyle.

We all make New Year's resolution and set a goal to change some things in a more meaningful manner in our life. One aspect, which most of us think to modify in our life relates to our body weight, physical and mental health, or our personality. Many are able to stick to these goals, but many of us fail also. It is difficult but not impossible to make changes in lifestyle especially with regards to engaging in regular physical activities or games.

With respect to our health, how do we sustain such goals is the most difficult question. We need to work out many strategies to motivate us to continue keeping health goals in sight. So being regular with physical activities, games, or sports that you wish to play or restricting eating junk food on a weekly basis or on most of the days is the key to maintain good physical and mental health.

HEALTHY LIFESTYLE AND HEALTH GOALS

A healthy lifestyle does not become part of our life in an instant. It is a series of choices we make every day consciously and continuously. Initially, the changes of opting a healthy lifestyle and undertaking wellness activities are difficult, but if we persist, it becomes a part of our new healthy behaviour. Therefore, it is important that healthy lifestyle activities are

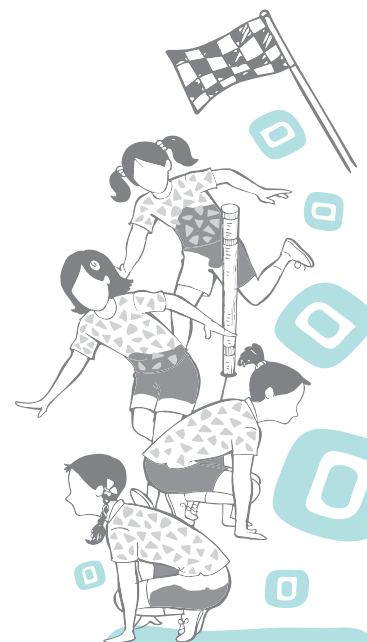

adopted as part of our life from early childhood and adolescent period itself. This helps to prevent or reverse the adverse effects of lifestyle disorders such as, poor eating habits and physical inactivity. In order to maintain health goals we can try the following strategies:

Set positive health goals: Having positive health goals keeps us motivated to follow goals with energy and enthusiasm. For example, a student may decide, 'I will skip dinner daily'. This is a determination with a negative mind. This type of goal does not train our mind for healthy lifestyle. Instead, the goal could be, 'I will eat healthy food'. This helps to make healthy food choices. Similarly, one can decide, "I will firmly say 'NO' to Tobacco use". Such goals help us to reinforce positive behaviours in the long term.

Set realistic goals: You would agree that many times we set health goals but fail to achieve them. For example, we may decide to exercise at least five days a week. But we have not been able to do so for about two weeks now. Gradually we lose track of our goal and we feel that now it's difficult to exercise. We slip into the attitude of either we follow it every day or none. This is because we give up as we have not been able to exercise for five days due to lack of time. In such situations, we should not feel guilty of failure. Rather we should re-visit and re-plan our goals related to regular physical activity or playing games, considering the real situations in our life.

FEW TIPS FOR MEETING HEALTH GOALS

Decide your health goal. Keep it easy for you to begin the act. Keep them 'SMART'. Think what problems could come in your way and how you can overcome these problems.

S - SPECIFIC: I will do jogging.

M - MEASURABLE: For at least 30 minutes, daily or three/four days in a week.

A - ACHIEVABLE: For five days in a week.

R - RELEVANT: I will reduce my body weight.

T - TIME BOUND: I will follow this schedule throughout the year.

Given below are some other aspects related to health. Write in the table below as per the 'SMART' goal to remain healthy.



Health Goals			
My Smart Goals are	Diet	Physical Activity	Any other
Specific			
Measurable			
Achievable			
Relevant			
Time-Bound			
Weight			

EFFORTS FOR ACHIEVING HEALTH GOALS AT INTERNATIONAL LEVEL—SUSTAINABLE DEVELOPMENT GOALS (SDGs)

The Millennium Development Goals (MDGs) were related to basic development issues. These were target-based, time bound and have been among the most successful global goals. Among the list of eight MDG goals, three were related to health. These goals stressed the importance of health challenges at the global level.

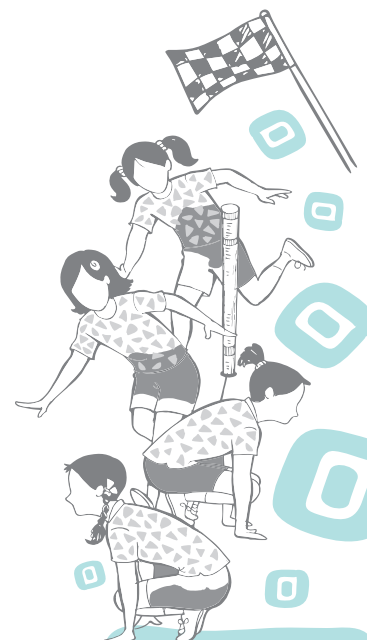

Fig. 2.2: Millenium development goals

The SDGs are also, known as ‘Transforming our world: the 2030 Agenda for Sustainable Development’. There are 17 Global Goals having 169 targets. SDGs also carry forward the unfinished agenda of MDGs for continuity and to sustain the momentum generated. These also aim to address the challenges of inclusiveness, equity, and urbanisation.



Fig. 2.3: Global goals for sustainable development



The third SDG—‘ensure healthy lives and promote well-being for all at all ages’—is wide-ranging as compared to the health goals in MDGs that were limited to child and maternal mortality and communicable diseases. The most important feature of SDG3 is universal health coverage which means to provide ‘access to good quality health services without financial hardship for people in need’.

The adolescents face challenges to their healthy development due to a variety of factors. Some of these include poverty, social discrimination, inadequate education, early marriage, and child-bearing. It is speculated that investments in adolescents will have an immediate, direct, and positive impact on India’s health goals.

Project on Sustainable Development

Prepare a project on any one SDG and focus on the following:

- Collect information about the targets set by UN for that goal.
- Describe what actions have been taken by our Government related to that goal?
- How can you contribute towards achieving the goal?
- You can make a poster related to the theme of this SDG. Place it in the classroom and discuss.

CONTRIBUTION OF PHYSICAL EDUCATION FOR PROMOTING HEALTH AND WELL-BEING

Physical health and mental health are inseparable. Daily exercise is important for gaining, reducing, or maintaining weight. Physical activities are fundamental for energy balance, and weight control.

These are important lifestyle related health determinants. Low levels of physical activity pose the greatest public health problems in India and many countries around the world.

Many lifestyle diseases today are because of lack of physical activities. Physical activity for a longer duration leads to deterioration of the essential body functions. A 20–30 per cent increased risk in all-cause mortality was seen in people with insufficient physical activity as compared to those who were involved in at least 150 minutes of moderate-intensity physical activity each week. (WHO, 2010)

Physical activity leads to maintenance or improvement in the functioning of the organs. It provides essential stimuli for most organs of the human body, in order to develop and maintain their structures and functions of life.



Physical activity is a key determinant of energy, balance, and weight control. The beneficial effects of physical activity go beyond controlling excess body weight. It reduces the risk for cardiovascular diseases, diabetes, blood pressure, and cancer. It improves the level of high density lipo protein cholesterol, improves the control of blood glucose in overweight people, even without significant weight loss.

WHO recommendations about physical activities for children and adolescents aged 5–17 years

- Should do at least 60 minutes from moderate to vigorous-intensity physical activity daily.
- Physical activities for more than 60 minutes daily will provide additional health benefits.
- Should include activities that strengthen muscle and bone, at least thrice in a week.

For age group 18–64 years

- Should do at least 150 minutes of moderate-intensity physical activity throughout the week, or do at least 75 minutes of vigorous-intensity physical activity throughout the week, or an equivalent combination of moderate and vigorous-intensity activity.
- For additional health benefits, adults should increase their moderate-intensity physical activity to 300 minutes per week, or equivalent.
- Muscle-strengthening activities should be done involving major muscle groups on two or more days a week.

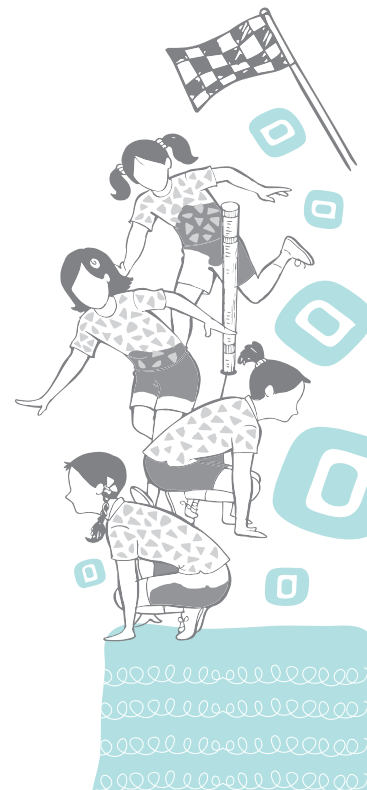

ASSESSMENT

I. Long Answer Questions

1. What are the common health needs of adolescents?
2. List all the dimensions of health and explain the emotional and spiritual dimensions briefly.
3. What are MDGs, and SDGs? How are these important for the world?
4. What are the benefits of engaging in regular physical activity to the adolescents and the young?
5. Explain the physical and mental dimensions of health.
6. How can we get good mental health? Explain.

II. Short Answer Questions

1. List some reasons due to which the adolescents do not utilise health services.
2. List important signs of stress and tension among the adolescents.
3. What are the causes of lifestyle diseases?
4. What are the benefits of setting positive health goals?
5. How much population of India is disabled currently?

III. Fill in the Blanks

1. Health is commonly understood as a state of absence of _____.
2. The Millennium Development Goals (MDGs) helped in focusing global attention and resources towards basic _____ issues.
3. Health indicates a sound _____, and sound _____.
4. _____ of health refers to the ability of individuals to interact with others in the socio-cultural environment.
5. Health of the children is a critical concern for all societies, since it contributes to their _____.
6. Schools play a vital role in promoting the health and safety of young people and helping them to establish lifelong _____.
7. _____ is a key determinant of energy expenditure, energy balance, and weight control.
8. The SDGs, known as 'Transforming our world: the 2030 Agenda for Sustainable Development' is a set of _____ Global Goals with _____ targets between them.



IV. State whether True or False

1. Health is influenced by biological, socio-cultural, economic, and environmental factors.
2. Lifestyle diseases are—Typhoid, Malaria, and Tuberculosis.
3. Mental health refers to the cognitive aspects of health that includes thinking, reasoning, remembering, imagining, and learning words.
4. Childhood is the stage during which the foundation of healthy life is laid.
5. Physical health and mental health are separable.
6. Not everyone wants to look good and healthy.

V. Skill based Questions

1. Find out the status of anaemia among the boys and girls in your State. What schemes have been developed by your State and the Government of India to tackle anaemia?
2. You have read about healthy diet in previous classes. Make a diet chart for an adolescent boy in the age group of 14–17 years.
3. Make a project on lifestyle diseases. What are the major lifestyle diseases? Discuss how one can prevent the lifestyle diseases.
4. Find out the desired minimum levels of physical activities for children, adolescents, and adults in different age groups.





PHYSICAL AND PHYSIOLOGICAL ASPECTS OF PHYSICAL EDUCATION AND SPORTS



11152CH03

3

Physical and physiological aspects of physical education and sports include growth and development, heredity and environment, and differences between growth and development. Factors affecting growth and development, and physical and physiological changes occurring during developmental stages are also discussed in this chapter. Physiological aspects include activities like warming up, conditioning and cooling down, effects of exercises on muscular, digestive, circulatory, and respiratory systems. These are also the part of this chapter.

GROWTH AND DEVELOPMENT

The terms growth and development are used in various aspects of life. Growth can be explained as becoming bigger or larger. Growth is termed as a physical change, whereas development includes physical, social, and psychological changes. Development also means transformation or improvement. Growth is related to quantitative improvement. Development is related to quantitative as well as qualitative improvement.

Growth

Growth refers to the process through which the body increases in size and shape. It is a biological process. In other words, growth means increase in mass. From the time of conception, the process of growth starts in the mother's womb. The fertilised egg continues to grow and after birth this process goes on till complete physical maturity is obtained. Growth is thus, a quantitative increase in size and shape. Physical growth refers to these changes in size and shape of different organs of the body, each of which normally proceeds at a different rate. Growth therefore, is a



tangible biological process in which the organism gains in terms of size, volume, height, and weight.

Development

Development is related with advancement and a progressive series of qualitative changes. Development processes have greater relationship with external factors than growth. Proper development cannot take place unless external factors such as nutrition, activity, and protection from diseases, and other socio-cultural influences are well ensured. More specifically development can be defined as the emerging and expanding of capabilities of the individual. Growth forms the basis for the development of functional capacities of the child. Without proper growth, probably the required level of development may not be achieved at a given stage. Acquisition of skills and knowledge also indicates developmental process. Although growth comes to end at some stage of life, development continues till death.

Table 1: Difference between Growth and Development

Growth	Development
Growth is visible.	Development can be observed.
Growth is quantitative.	Development is quantitative as well as qualitative.
Growth comprises of height, weight, size, and shape of body and its organs.	Along with the physical changes, cognitive, social, and emotional changes are also included.
It is due to cell division.	It happens due to motor and mental processes and their interplay.
Growth is for limited period.	Development is a life long process.
Growth can be measured objectively.	It can be observed by matured behaviour.
Growth tells about one aspect of the personality and is limited in scope.	Development deals with all the aspects of personality and has a vast scope.
Growth can be measured and continues up to certain age of an individual.	Development is more related to qualitative aspect and difficult to measure for instance, mental ability, academic achievement, etc.
The limits of the growth are set by the heredity of an individual.	Development is more affected by the environment available to the person.

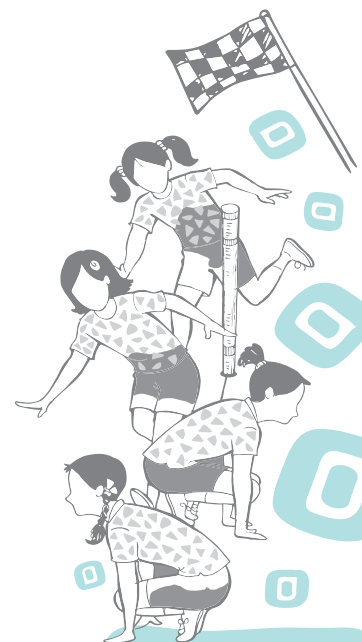

FACTORS AFFECTING GROWTH AND DEVELOPMENT

The following factors influence the growth and development of a living organism.

Heredity

Heredity is a biological process that plays an important role in the transmission of physical and social attributes from parents to their children. Height, weight and structure of the body, colour of hair and eyes, intelligence, aptitudes, and instincts of the child are highly influenced by heredity.

The behaviour of a living organism is influenced by two factors—heredity and environment. The biological or psychological characteristics which are transmitted by the parents to their children are known by the name of heredity. It is a biological process of transmission of certain traits of appearance and behaviour of the parents towards their offsprings. Heredity traits are innate, they are present at birth. The essential characteristics inherited by all human beings are physical structure, reflexes, innate drives, intelligence, temperament, etc.

Environment

Environment plays an important role in human life. Psychologically a person's environment consists of the sum total of the stimulations (physical and psychological) which is received from the conception. There are three different types of environment, such as—

1. **Physical:** It consists of all outer physical surroundings. These are both animate and inanimate which have to be manipulated in order to provide food, clothing, and shelter. Geographical conditions such as weather, climate, and physical environment also have considerable impact on an individual child.
2. **Social:** It is constituted by the society, individuals, institutions, social laws, and customs that regulate human behaviour. It refers to the physical and social setting in which a child lives. It includes culture, education, human settlement, etc.
3. **Psychological:** It is rooted in an individual's reaction with an object and situation. One's love, affection, emotion, and feeling of friendship and brotherhood will strengthen human bond with one another.

Environment is the sum total of the surroundings in which an individual has to live. It is generally divided into two categories—natural and social. Natural environment



refers to all those things and forces on, and around the earth that are natural and influence a person. Social environment means the environment which one sees around oneself on acquiring consciousness in the society, i.e., languages, religions, customs, traditions, means of communication, means of luxury, family, school, social groups, etc.

Role of Heredity and Environment on Growth and Development

- Heredity is responsible for all the inborn traits, instincts, emotions, and physical traits.
- Environment is responsible for the growth and development of the mental and social traits.
- The two forces heredity and environment are complementary to each other like seed and soil, ship and wave, etc.

So growth and development are regulated by the surrounding environment of a child, or where an individual lives.

Gender

Gender acts as an important factor in human growth and development. Boys in general are taller, heavier in comparison to the girls but girls demonstrate early physical growth during adolescence than boys. The body composition and structural growth of girls are different from boys.

Nutrition

Growth and development of the child depends on food habits and nutrition. The human body requires an adequate supply of calories for its normal growth and this requirement varies with phases of development. Malnutrition has an adverse effect on the structural and functional development of the child.

Exercise

Physical exercises have positive impact on growth and development of the children. The functional activities come in the form of exercises of the body. It means growth through use and atrophy (the reverse of growth) through disuse.

The growth of muscles from the normal functioning of the child is a matter of common knowledge. It is a fact that repeated physical activity builds the strength of the muscle. The increase in muscular strength is mainly due to better circulation and good stimulation supply of nutrients and oxygen to the muscles. Play and other physical activities provide for the growth and development of skeletal muscles.

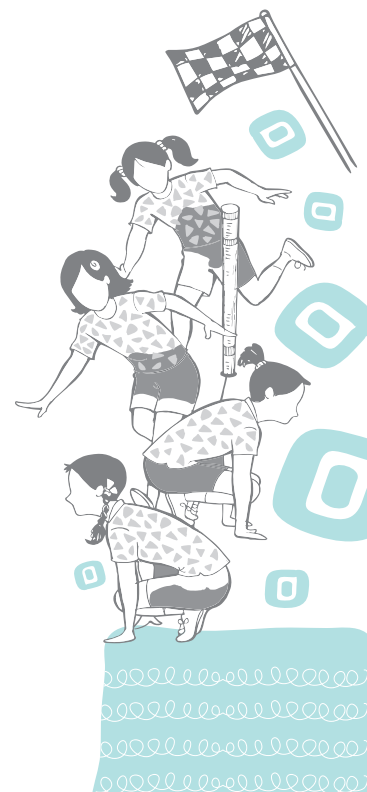

Hormones

Hormones are chemical substances and play an important role in regulating the process of growth and development. There are many endocrine glands present inside our body. Endocrine glands are ductless glands and are situated in some specific parts of the body. These glands make internal secretions locally and produce one or more hormones.

Hormones are physiological substances having the power to increase or decrease the activity level of the body or certain organs of the body. For example, thyroid gland releases thyroxin hormone which influences the skeletal and muscular growth. In the absence of this hormone in appropriate proportion, growth and development is affected.

Similarly, the adrenal glands are situated very close to kidneys. These secrete adrenaline, which is responsible for strong and rapid heartbeat, release of stored sugar from liver and controls blood pressure. Gonads are reproductive glands, which secrete hormones that affect our growth and sexual behaviour.

Learning and Reinforcement

Learning is the most important and fundamental topic in the whole science of psychology. Development consists of maturation and learning. Learning includes much more than school learning. Learning goes to help the child in the physical, mental, emotional, intellectual, social, and attitudinal developments. All knowledge and skill, all good and bad habits, all acquaintances with people and things, all attitudes built up while dealing with people and things are learned.

Reinforcement is an important factor in learning. Exercise or activity is necessary for learning. It may be a motor activity, as in playing on a musical instrument, or it may be a sensory activity as in listening to a piece of music. Whatsoever, there must be activity in some form. 'Learning by doing', is an old psychological proverb. Now it is accepted that, activity should be repeated till we get the desired results. So the saying should be replaced as 'learning by doing and getting results'.

Pollution

According to studies, air pollution not only affects the respiratory organs but also has harmful effects on human growth. Indoor pollution or the pollution from housing conditions can result in ill health which can negatively impact human growth and development. For example, lead exposure from deteriorated lead-based paint in older housing can be very harmful. Lead is very harmful for children as

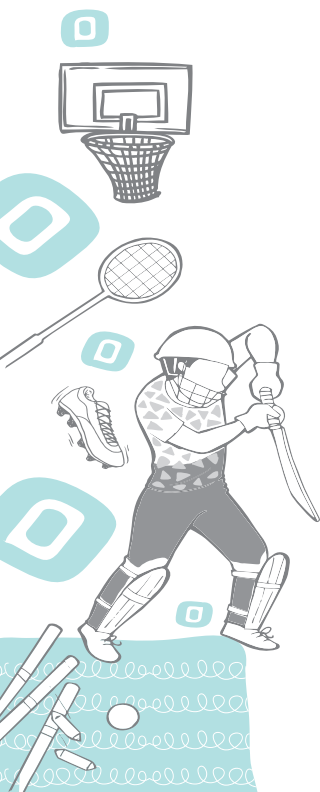

it simply gets immersed into the growing bodies of children and obstructs the normal development of brain and other organs and systems.

Socio-economic Status

Socio-economic factors definitely have some effect. It has been seen that children from different socio-economic background vary in average body size at all ages. The families with high income are primarily more advanced. The most important reasons behind this are better nutrition, better facilities, regular meals, sleep, and exercise. Family size also influences the growth rate, as in big families with limited income, sometimes children do not get the proper nutrition and hence the growth is affected.

PHYSICAL AND PHYSIOLOGICAL CHANGES DURING DEVELOPMENTAL STAGES

Early Childhood

Early childhood is a time of tremendous growth across all the areas of development. Physically, between birth and age of three, a child typically doubles in height and quadruples in weight. A typical three-year-old might have mastered many skills, including sitting, walking, toilet training, using a spoon, scribbling, and sufficient hand-eye coordination to catch and throw anything. Between three and five years of age, children continue to grow rapidly and begin to develop fine-motor skills. By the age of five, most children demonstrate fairly good control of pencils, crayons, and scissors. Gross motor accomplishments may include the ability to skip and balance on one foot. Physical growth slows down between five and eight years of age, while body proportions and motor skills become more refined. Physical changes in early childhood are accompanied by rapid changes in the child's cognitive and language development.

Middle Childhood

Middle childhood has not been considered an important stage in human development as compared to early childhood. Physical development during middle childhood is less dramatic than in early childhood or adolescence. Growth is slow and steady until the onset of puberty, when individuals begin to develop at a much quicker pace. The age at which individuals enter puberty varies, but there is evidence of a visible trend—the age at which puberty begins has been decreasing over time. In some individuals, puberty may start

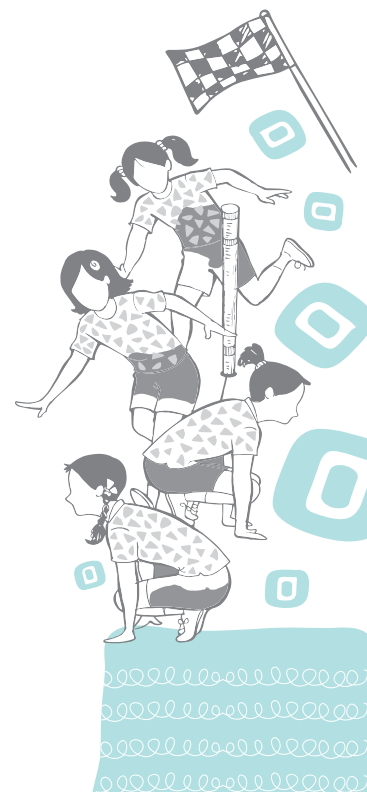

Do You Know?

About 2.21 per cent of the total population of India is 'disabled'. The highest number of disabled persons in India is from the State of Uttar Pradesh. At all India level, 7.62 per cent of the disabled persons belong to the age group of 0–6 years. Focus today is on inclusive Education.

Source: Census 2011

as early as at age eight or nine. The onset of puberty differs across gender and begins earlier in females. The cognitive development of middle childhood is slow and steady. Middle childhood is a time when children can gain enthusiasm for learning, and work for achievement can become a motivating factor as children work toward building competence and self-esteem.

Adolescence

The adolescent years are the second period of accelerated growth. The age between 12 and 18 years is generally considered as 'adolescence'. Individuals may gain a total of 15–20 centimeters in height and as much as 8–10 kg in weight. The timing of this growth spurt is not highly predictable; it varies across both, individuals and gender. In general, females begin to develop earlier than males. Sexual maturation is one of the most significant developments during this time. Like physical development, there is significant variability in the age at which individuals attain sexual maturity. Females tend to mature at about age thirteen, and males mature at about age fifteen. Adolescence is also an important period for cognitive development.

PHYSIOLOGICAL ASPECTS OF ACTIVITIES

The body's physiological responses to exercise occur in the musculoskeletal, cardiovascular, respiratory, endocrine, and immune systems. Different types of exercises will have different effects upon the muscles exercised. Before

performing any exercise, or workout body has to be warmed up properly for the efficient and effective functioning of muscles.

Warm-up

Warming up is a short time activity carried out prior to any intense or skilled activity. It is important to warm up before exercising, which is usually done by including 10 to 40 minutes of light activities, such as, slow jog, calisthenics, and stretching. Players need warm-up as it increases body temperature and heart rate, provide stretching, stimulate the entire body and major

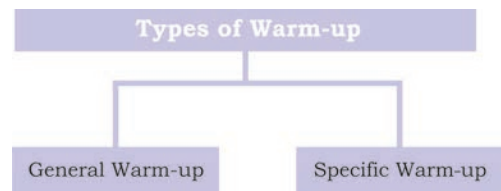
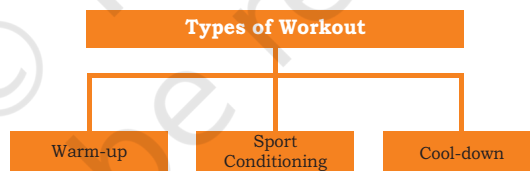

biomechanical functions, provide practice for basic movements, and finally prepare the player or athlete for rigorous athletic activity/training. Stretching results in increased blood flow and prevents injuries to the muscles, tendons, and ligaments. Proper warm-up exercises are not supposed to be done vigorously. A warm-up generally consists of a gradual increase in intensity of physical activity (a 'pulse raiser'), joint mobility exercise, and stretching, followed by the main activity. Warming up brings the body to a condition at which it safely responds to nerve signals for quick and efficient action. The objectives of the warm-up are to increase heart rate, blood flow, internal temperature of the muscles, respiratory rate, perspiration, and decrease the viscosity of joint fluids.

A warm-up is intended to raise the body temperature and prepare a player physiologically and psychologically to compete in a game. Researchers have suggested that the optimum duration of the warm-up period, should be between 15 to 20 minutes. This should consist of a gradual increase in intensity until the player is working at 70 per cent of maximal heart rate. A warm-up at this intensity has the effect of allowing an increase in the range of movement of the joints and improving aerobic performance. This means the player becomes more flexible and movement efficiency improves. A warm-up produces a 2 to 3 degree rise in body temperature that can last for 45 minutes.



Fig. 3.1: General warm-up exercises

General Warm-up

It involves rhythmic movements using large muscle groups. The general warm-up should consist of a light physical activity

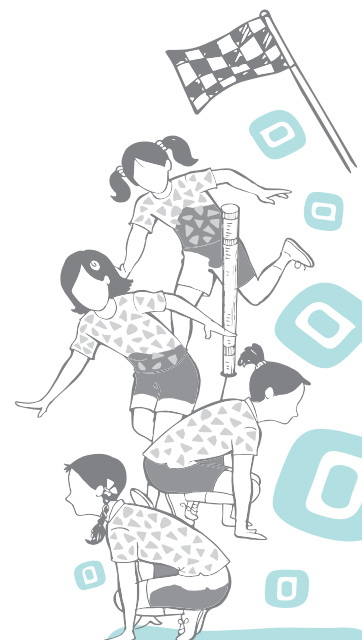

like walking, jogging, stationary bike, skipping, or easy aerobics. It is also beneficial in improving neuromuscular coordination of muscles that results in developing better control on muscles. This warming up in turn increases the body temperature resulting in reduced viscosity in muscle fibres and thus helps in getting better results. Both the intensity and duration of the general warm-up (or how hard and how long), should be governed by the fitness level of the participating athlete.

Specific Warm-up

It consists of specific exercises which are matched to the main activity. In specific warm-up, some special sets of exercises need to be performed which have a direct relation with the activity to be carried out. In this part, the athletes are specifically preparing their body for the demands of their particular sport. During this part of the warm-up, more vigorous activity should be employed. Activities should reflect the type of movements and actions which will be required during the sporting event. The set of activities and exercises in specific warming up differ from sport to sport. These are especially designed to meet the requirement of different activities and sports.

For example in weightlifting, the athlete first needs to perform some exercises with a bar for specific warm-up. Similarly a basketball player practices layup shots or free throws before the competition, this helps to improve their coordinating abilities. Different games have their own specific warm-up exercises. Some of them are described (along with the games they concern) as follows:

1. Basketball—shooting, dribbling, lay-up shots, free throws, shuttle run, dodging, etc.
2. Cricket—bowling, catching, batting, fielding, running, etc.
3. Lawn Tennis—wall practice, service practice, passing shots, knocking, etc.
4. Shot put—standing throws, putting the shot with both hands, gliding practice with or without shot, shifting the shot from left hand to right hand, and vice-versa.
5. Hockey—dribbling, rotation of stick, short passes, long hits, scoop, stopping the ball with stick, etc.
6. Weightlifting—warming up rowing, high pull, snatch squat, shoulder shrug, good morning exercise, etc.



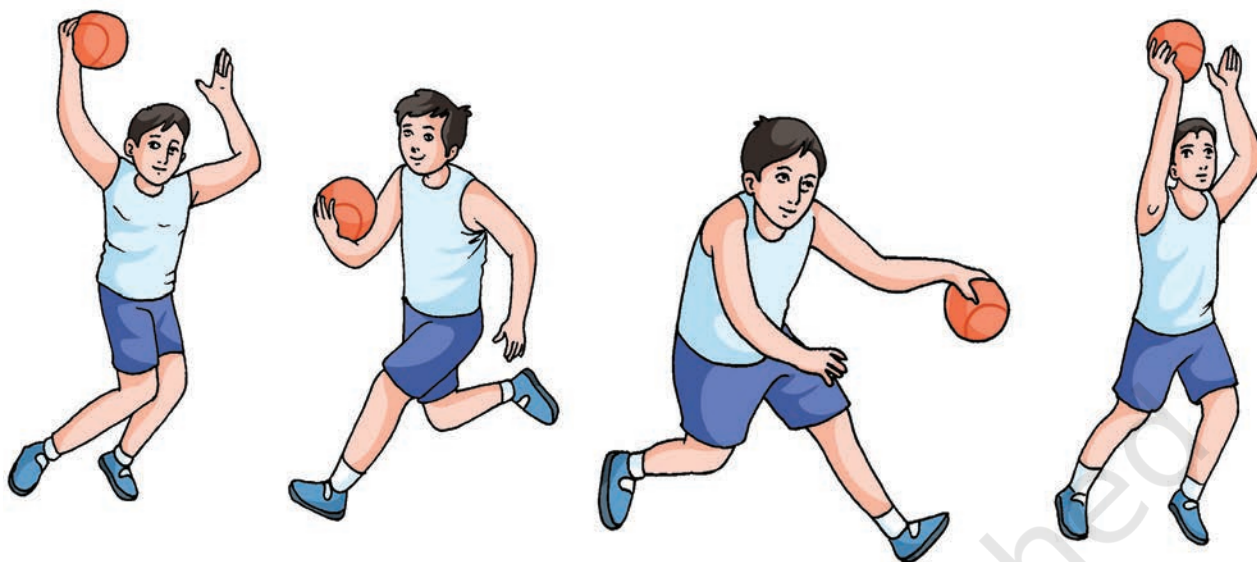

Fig. 3.2: Different types of warming up drills in basketball

Methods of Warming up

There are various methods of warming up for different games and sports, the most commonly used are by—

1. exercise
2. massage
3. taking hot water bath
4. sipping some hot beverages.

Exercise

Most sets of warm-up exercises include four to five very simple movements. The exercises that are included in this method are walking, jogging, running, jumping, bending, stretching exercises, etc.

Massage

Massaging of muscles is a good method to gain muscle tone and is an effective means of warming up. It helps in the removal of lactic acid and recovery from fatigue and healing of minor injuries of muscles.

Hot Water Bath

This technique is very helpful in warming up and relaxation of muscles after competition. A hot water bath is helpful in raising body temperature which results in the activation of muscles by increasing blood circulation in them.

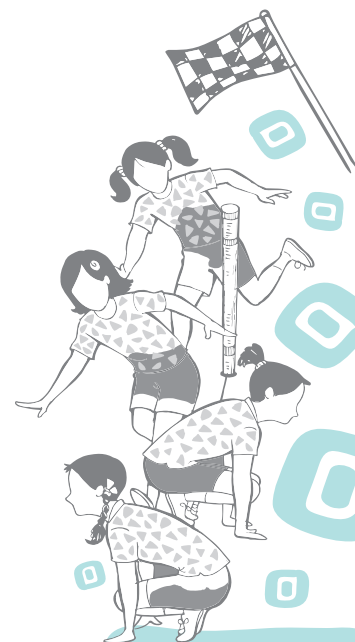

Hot Beverage

A small intake of tea, soup, coffee, or any other hot beverage stimulates the body functions and helps in preparing the body for competition. The drink should not be consumed in large quantities as it may cause discomfort.

Things to take into account when performing the warm-up:

- Always start with a continuous slow run to prepare the body and increase temperature. Move all the parts of your body, from head to toes.
- Do not get tired; don't make too many repetitions of each movement and move the alternate parts of the body.
- It has to be progressive, from low-intensity to high-intensity exercises.
- End up with some sprints or short, and fast races. It should last for 10–15 minutes, and your heart rate should increase until 120–140 beats/minute.

Sports Conditioning

Sports conditioning offers an edge over the competition. The purpose of sports conditioning is to complement current sports training. Sports conditioning is ideal for children who strive for greater performance in any sporting activity. It is meant to enhance an individual's strength, balance, coordination, flexibility, speed, and power, which can be carried over into all the sports.

The conditioning programme is an important step in injury prevention. Proper training can reduce the incidence of injury in young athletes and also offers the teams a chance to grow strong together. Sports conditioning helps to prepare athletes for better application of their sport-specific skills. Athletes of all levels and abilities need a more sports-oriented training programme besides general fitness.

Sports conditioning should be directly related to the type of sport in which the individual participates. A good conditioning programme includes strength, power, speed, quickness, agility, movement, skills, deceleration, balance, reactivity, and anaerobic capacity.

The conditioning programme should be specific to the sport and should meet the individual needs of the athlete.

Limber down or Cool down

Cool down is a session of light exercises that follows rigorous physical activities. The session will usually include gentle exercises, and stretching activities. Stretching is a major factor in the procedure of cooling down. Stretching allows the body muscles to build elasticity and repair from aerobic and anaerobic exercises.



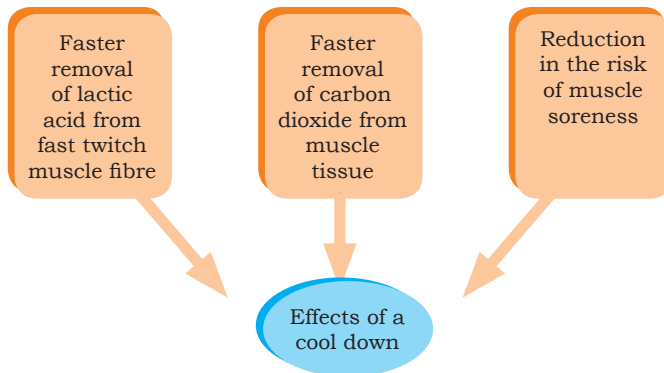

Cooling down is an easy exercise, done after a more intense activity, to allow the body to gradually transition to a resting or near resting state.

The main aim of the cool down session is to promote recovery and return the body to a pre-exercise, or pre-workout level. During a strenuous workout, the body goes through a number of stressful processes. For example, muscle fibres, tendons and ligaments get damaged, and waste products build up within the body.

Effects of Cooling down

1. Helps heart rate and breathing to return towards resting levels gradually.
2. Helps avoid fainting or dizziness, which can result from blood pooling in the large muscles of the legs when a vigorous activity is stopped suddenly.
3. Helps to remove metabolites (intermediate substances formed during metabolism) from muscles, such as lactic acid.
4. Helps to prepare the muscles for the next exercise session, whether it's the next day or in a few days' time.

Effects of Exercise on various Body Systems

Effects of Exercise on Cardiovascular System

Cardiovascular is the system of heart, blood vessels, and blood. The effects of exercise on cardiovascular system are summarised as—

Heart rate: The number of beats or contractions of heart in one minute is called as heart rate. The number of contractions ranges from 60 to 80 beats/minute. However, 72 beats/minute is considered as the normal heart rate. During exercise, the heart rate increases and may range from 140 to 180 beats/minute depending on the intensity of exercise.

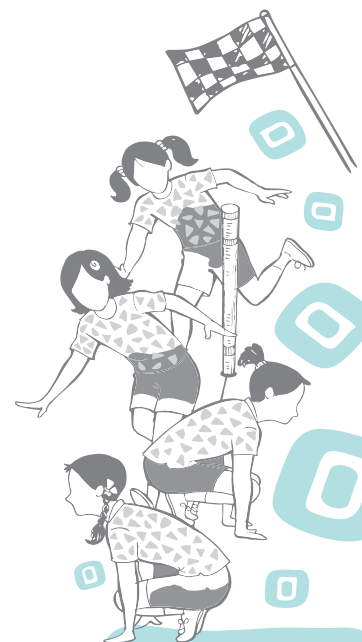

Do You Know?

There are two main types of muscle fibers; fast twitch muscle fibre and slow twitch muscle fibre.

Activity 3.1

Record the heart rate from radial artery or carotid artery before and after completing 100 metre sprint.

Stroke volume: The amount of blood pumped out by each ventricle in each heartbeat is known as stroke volume. At rest, the stroke volume is around 70 ml/beat for male and 50 ml/beat for female, during exercise the stroke volume increases.

Cardiac output: It is the amount of blood pumped out by each ventricle of the heart in one minute. It is the product of stroke volume and heart rate. Endurance training results in increased cardiac output through increased stroke volume. Cardiac output increases directly with increased exercise.

Cardiac output = Heart rate × Stroke volume

At rest it is around 5 litre/minute; during exercise the increase may be about 4 to 5 fold.

Cardiac hypertrophy: Hypertrophy is the increase in the volume of an organ or tissue due to the enlargement of its component cells. Cardiac hypertrophy is referred to as 'athlete' heart, which may occur after 7–10 years of vigorous physical training.

Blood volume: The blood is a reddish fluid, alkaline in reaction and is salty in taste. The body of an adult contains about 5–6 litres of blood which weighs 1/3rd of the total body weight. Exercise produces the following effects.

- The effect of exercise on blood volume depends on the type and intensity of exercise.
- During endurance training, the resting blood volume increases approximately by 8 per cent.
- Plasma volume in the blood increases by 12 per cent.
- Increase in blood volume is known as hemodilution.
- Increase in the number of blood vessels and their size too.
- By continuous and endurance training, capillarisation takes place.

Effects of Exercise on Respiratory System

The mechanism of inspiration and expiration is known as respiration. It is controlled by medulla oblongata of the brain. It helps in adequate supply of O₂ and elimination of CO₂ from the body. The effects of exercise on respiratory system are summarised as follows:

Tidal volume: It is referred to as the volume of air inspired or expired per breath. During rest, it is around 500 ml; during exercise it increases; during maximal



exercise, it increases 5 to 6 times above the resting values.

Respiratory rate (F): It is also known as breathing rate or breathing frequency. It is defined as the number of breaths per minute. At rest, it is 12–20 per minute, during exercise it increases to 2–3 times.

Minute ventilation or Pulmonary ventilation (PV): It is commonly referred to as the breathing process of lungs during inhalation and exhalation.

PV = Tidal volume × Respiratory rate

PV = (TV × RR)

During rest = 8 litres/minute

(PV changes with body size, it is smaller in female and larger in male.)

During exercise: PV increases during exercising. The initial rise in the ventilation is due to the increased stimulation of the inspiratory centres caused by muscular activity. The second phase of gradual increase in the ventilation occurs due to an increase in the temperature, and chemical changes in the arterial blood produced by muscular activity.

Pulmonary diffusing capacity: The rate of diffusion of gas between the alveoli of the lungs and the blood of the lung capillaries is called pulmonary diffusing capacity. During exercise the pulmonary diffusing capacity for oxygen increases.

Hyperventilation: An increased breathing due to an increased tidal volume or increasing respiratory rate or both is referred to as hyperventilation.

Total lung capacity: The volume of air in the lungs at the end of maximal inspiration is termed as total lung capacity. During exercise the total lung capacity slightly decreases.

Vital capacity: The maximal volume of air which is forcefully expired after maximal inspiration is called vital capacity.

Effects of Exercise on Muscular System

Muscle is a tissue which has the power of contraction. Skeletal muscles are the main muscles for physical activities and exercises. Several changes take place in the skeletal muscles depending upon the type of training which an individual is undergoing. The effects of exercise on muscular system are summarised as follows.

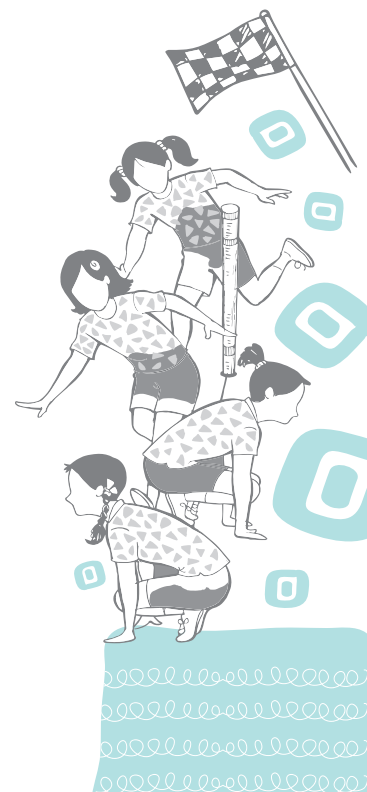

Muscular hypertrophy: Due to regular exercise, training muscles become enlarged. Muscle fibers, diameter and length increases. The total amount of protein, glycogen and enzymes are increased.

Aerobic changes: By training, the amount of myoglobin increases which helps for better supply of O_2 to the working muscles of the body. By training, muscles produce energy by increased oxidation of glycogen. A trained muscle uses more fat to supply more energy.

Anaerobic changes: These are the changes which help in supply of energy in the absence of O_2 .

- Increased lactic acid tolerance
- Change in blood flow of the muscles
- Change in red and white fibres of the muscles

Training and capillary supply: Endurance training increases the capillary ratio (expressed as capillaries per fiber). Training increases capillary density as well.

Influence on performance: As muscles become stronger, they contract with less exertion during a maximum voluntary force. A greater perfusion occurs, and the exercise can be continued without involving the anaerobic metabolism. This would help in delaying the lactic acid accumulation and increase in the muscular force. Strength, flexibility and endurance are increased after the training.

Effects of exercise on Digestive System

There are many effects of exercise on the body that can positively influence digestive system functioning. Regular exercise makes our digestive system strong, speeding up metabolism and preventing constipation. The short term effects of exercise on the digestive system are—

Blood flow increases: Exercise can improve the blood flow. Circulation of blood in all the areas of body also includes the digestive track organs and enhance their functioning.

Speedup metabolism: Exercise can boost our metabolism. Exercise can slightly increase our resting metabolic rate (the amount of calories our body burns at rest). Metabolism is the process in which the food we consume is converted into energy that is needed by the body to survive.

Prevent constipation: Exercise helps in reducing constipation by decreasing the time taken by food to move through the large intestine, thus limiting the



amount of water absorbed from the stool in to the body. Exercise accelerates our breathing and heart rate. This helps to stimulate the natural contraction of the intestinal muscles which prevent constipation naturally.

Prevent digestive diseases: Regular exercise helps to prevent digestive diseases. Many diseases are associated with stomach and if we exercise regularly, that will strengthen our internal organs, such as liver, stomach, intestine, various glands, etc., and prevents us from digestive diseases.

© NCERT
not to be republished

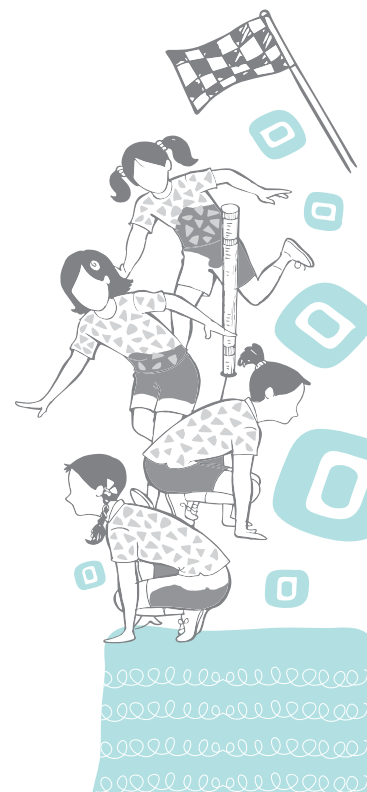

ASSESSMENT

I. Long Answer Questions

1. What is the difference between growth and development? Explain.
2. Define growth and development and explain the factors affecting growth and development.
3. Explain the effects of exercise on muscular system.
4. Enlist and explain the effects of exercise on respiratory system.
5. Explain physical and physiological changes that take place during different developmental stages.

II. Short Answer Questions

1. What is meant by cardiac output?
2. Write down the full form of MV.
3. What is Muscle Hypertrophy?
4. List the developmental stages of life.
5. What is general warm-up?
6. What is specific warm-up?

III. Fill in the Blanks

1. Growth refers to the process through which body increases in _____ and _____.
2. There are _____ major factors which directly or indirectly influence the growth and development of a _____.
3. Hormones play an important role in regulating the process of _____ and _____.
4. An increased tidal volume, or increased respiratory rate, or both is referred to as _____.
5. Heart rate _____ during submaximal exercise and it is caused due to increase in _____ activity.
6. _____ with high velocity movement develops exploring strength or power.

IV. Match the Following

- | | |
|--------------------|-------------------|
| 1. Stroke Volume | a. Lung |
| 2. Residual Volume | b. Muscles |
| 3. Lactic Acid | c. Heart |
| 4. Snatch | d. Basketball |
| 5. Gliding | e. Weight lifting |





INDIVIDUAL GAMES

4



Games and sports are important parts of our lives. They are essential to enjoy overall health and well-being. Sports and games offer numerous advantages and are thus highly recommended for everyone irrespective of their age. Sports with individualistic approach characterised with graceful skills of players are individual sports. Do you like the idea of playing an individual sport and be responsible for your win or loss, success or failure? There are various sports that come under this category. This chapter will help you to enhance your knowledge about Athletics, Badminton, Gymnastics, Judo, Swimming, Table Tennis, and Wrestling.

ATHLETICS

Running, jumping and throwing are natural and universal forms of human physical expression. Track and field events are the improved versions of all these. These are among the oldest of all sporting competitions. Athletics consist of track and field events. In the track events, competitions of races of different distances are conducted. The different track and field events have their roots in ancient human history.

History

Ancient Olympic Games are the first recorded examples of organised track and field events. In 776 B.C., in Olympia, Greece, only one event was contested which was known as the stadion footrace. The scope of the games expanded in later years. Further it included running competitions, but the introduction of the Ancient Olympic pentathlon marked a step towards track and field as it is recognised today. There were five events in pentathlon namely—discus throw, long jump, javelin throw, the stadion foot race, and wrestling.

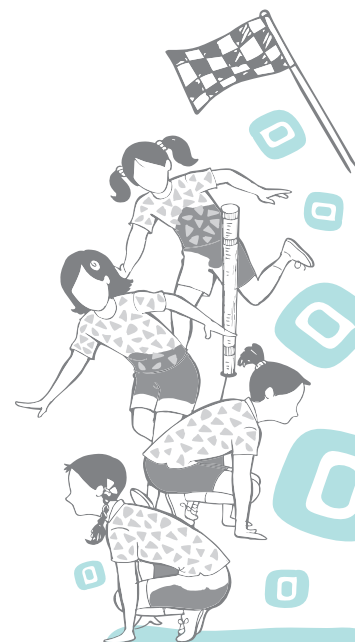

Activity 4.1

Athletics at the 1960 Summer Paralympics consisted of 25 events, 13 for men and 12 for women. Prepare the list of these events both for men and women.

Track and field events were also present at the Pan-Hellenic Games in Greece around 200 B.C. period and spread to Rome in Italy. Track and field events began developing in parts of Northern Europe in the middle ages. The stone put and weight throw competitions popular among Celtic societies in Ireland and Scotland were predecessor to the modern shot put and hammer throw events. Pole vault is the last track and field events which evolved in the eighteenth century.

In the late 19th century, modern track and field competitions were separated from general sporting festivals and were first recorded. These competitions were typically organised by educational institutions, military organisations, and sports clubs. Competitive hurdling first came into being, with the advent of the steeplechase in England around 1850. The first national body for the sport of athletics, The Amateur Athletic Association (AAA) was established in England in 1880. Under this grouping, track and field became the focus of the annual AAA Championships. The United States also began holding an annual national competition. The USA outdoor Track and Field Championship was held in 1868 by the New York Athletic Club.

The establishment of the modern Olympic Games at the end of the nineteenth century marked a new height for track and field events. The Olympic athletics programme comprised of track and field events including a marathon race. These also contained many of the foremost sporting competitions of the 1896 Summer Olympics.

The Olympics also consolidated the use of metric measurements in international track and field events, both for race distances and for measuring jumps and throws. The athletics programme greatly expanded over the next decades and remained most prominent among the games. The Olympics were the elite competitions for track and field, and only amateur sportsmen at that time could compete. Track and field continues to be largely an amateur sport.

The International Amateur Athletic Federation (IAAF) was established in 1912, becoming the international governing body for track and field.

Indian History of Athletics

In the history of Indian Athletics, the decade of 1940's to 1950's is important as a number of Athletics associations were started in this decade. In 1946, the Amateur Athletics Federation of India (AAFI) was established for the management of Indian Athletics. The entire scenario of Indian Athletics was changed by AAFI as it worked in collaboration with



the other Athletics associations for improving sports and athletics. Indian Athletics went through many phases. Many track and field games were played in the grass.

At present synthetic track is used which has made things easier as there was no need for manual marking of tracks and associated definitions for throws and jumps in those tracks. Application of technology has helped the athletes and improved the status of the sport.

India has so far produced a number of successful athletes in the international level who have a rich tradition of winning performances in the international tournaments.

Some of the most successful athletes in the early history of Indian Athletics are Milkha Singh, T.C. Yohannan, Gurbachan Singh, Sriram Singh, etc. Some of the notable Indian Athletes in the contemporary period include P.T. Usha, Anju Bobby George, Jyotirmoyee Sikdar, Saraswati Saha, Soma Biswas, etc.

Classification of Athletics Events

According to the nature of competitions, athletics events are classified into four types. These are—

Track Events: All running events come under track events.

Field Events: The jumping and throwing events are called field events.

Combined Events: There are some other unique events which are called as combined events. These are also organised in athletics. In fact, these are the combination of some track and field events, such as decathlon, heptathlon, etc.

Events conducted outside the stadium: These events are held outside the track, on roads or at natural places; for example, Marathon of 42.195 km and 20 and 50 km walk.

Classification of Track Events

Track events are classified into three categories. These are—

Table 1: Classification of Track Events

1. Short Distance Races	2. Middle Distance Races	3. Long Distance Races
100 m	800 m	3000 m steeplechase

Activity 4.2

Collect information about your favourite athletes and share in the class.

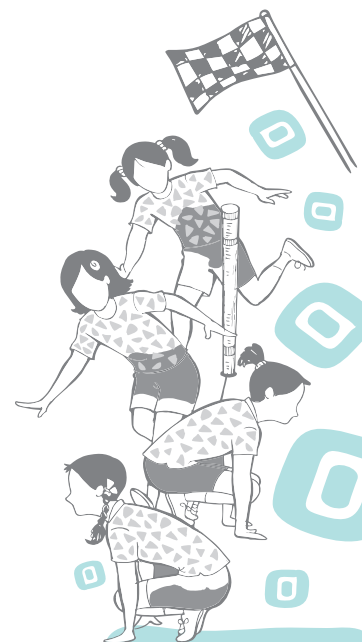

200 m	1500 m	5000 m
400 m		10,000 m
110 m Hurdle Race (Men)		20 km walking
100 m Hurdle Race (Women)		Road Events
400 m Hurdle Race		
4×100 m relay		50 km walking
4×400 m relay		Marathon (42.195 m)

Do You Know?

- Sebastian Coe from Great Britain was one of the world's greatest athlete winner of four medals at Olympic Games, and had not taken a single day rest between his training.
- Steeplechase—A hurdle race with water jumps came into existence in England around 1850.

Classification of Field Events

Field events are classified into two categories—jumping events and throwing events. Further these are classified as given below:

Table 2: Classification of Field Events

Jumping Events	Throwing Events
Long Jump	Shot Put
High Jump	Discus Throw
Triple Jump	Javelin Throw
Pole Vault	Hammer Throw

Classification of Combined Events

Combined events are those events which are characterised as mixed events from the track as well as field events. For men there are mixed events called 'Decathlon' and comprised of 10 events to be completed within the span of two days. Combined track and field events for women are called 'Heptathlon' and are divided into seven events. These mixed events are classified below.

Table 3: Classification of Combined Events

Decathlon (Men)		Heptathlon (Women)	
100 m	1st day	100 m	1st day
Long Jump		High Jump	
Shot Put		Shot Put	
High Jump		200 m	
400 m			

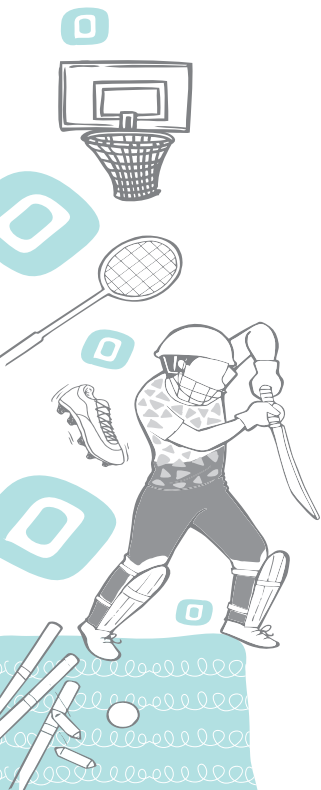

110 m Hurdle	2nd day	Long Jump	2nd day
Discus Throw			
Pole Vault		Javelin Throw	
Javelin Throw		800 m	
1500 m			

Activity 4.3

Collect the information about the events under 'Decathlon' and 'Heptathlon', which are to be completed on the first day of the competition and on the second day of competition.

General Rules

These are some of the general rules which need to be followed by every athlete during the events.

- The athlete should run with shoes.
- There should be a number on the chest and back of every athlete. No athlete can participate without the number. Only in the games of Pole Vault and High Jump, an athlete can bear one number.
- If an athlete runs before the gun is fired, it is considered as a foul and is expelled from the event. Only in the combined events, the athlete is given a warning for first foul, but on the second foul, the athlete is expelled from the game.
- The starter speaks in English at the time of start.
- If any athlete obstructs the other athlete, then the referee can expel that athlete.
- In the races up to 400 m, all the athletes have to finish them in the same lane allotted to them.
- 800 m race starts in lanes but lanes are changed to first lane after the first curve.

Athletics Track

A track is formed by two straight lines and two curved lines. It is oval shaped. Track surface can be of soil, grass, or synthetic. In the national and international competitions, the synthetic tracks, which are also known as all-weather tracks are used. In all races up to and including 400 m, each athlete has a separate lane, with a width of 1.22 m to 1.25 m to be marked by lines 5 cm in width.

Methods of starting the Race

Each race is started with a starting gun. The main two types of start are—

Crouch Start: This type of start is essential for sprint races. Starting block is used in this start, so the athlete can better use their reaction, speed, and explosive power.

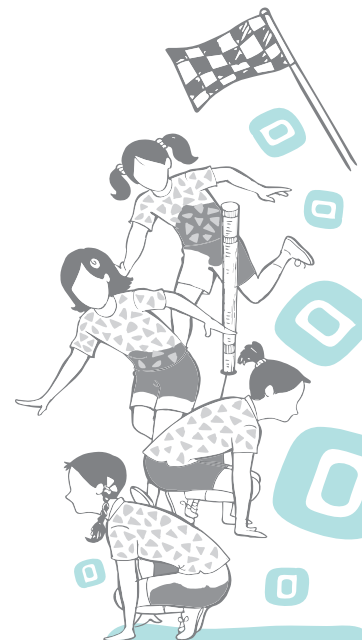

Do You Know?

- Starting line in the track events is included and the Finish line is excluded. Line on the right hand side of the lane is included in the width of each lane.
- No check marks are permitted in the track except for relays.

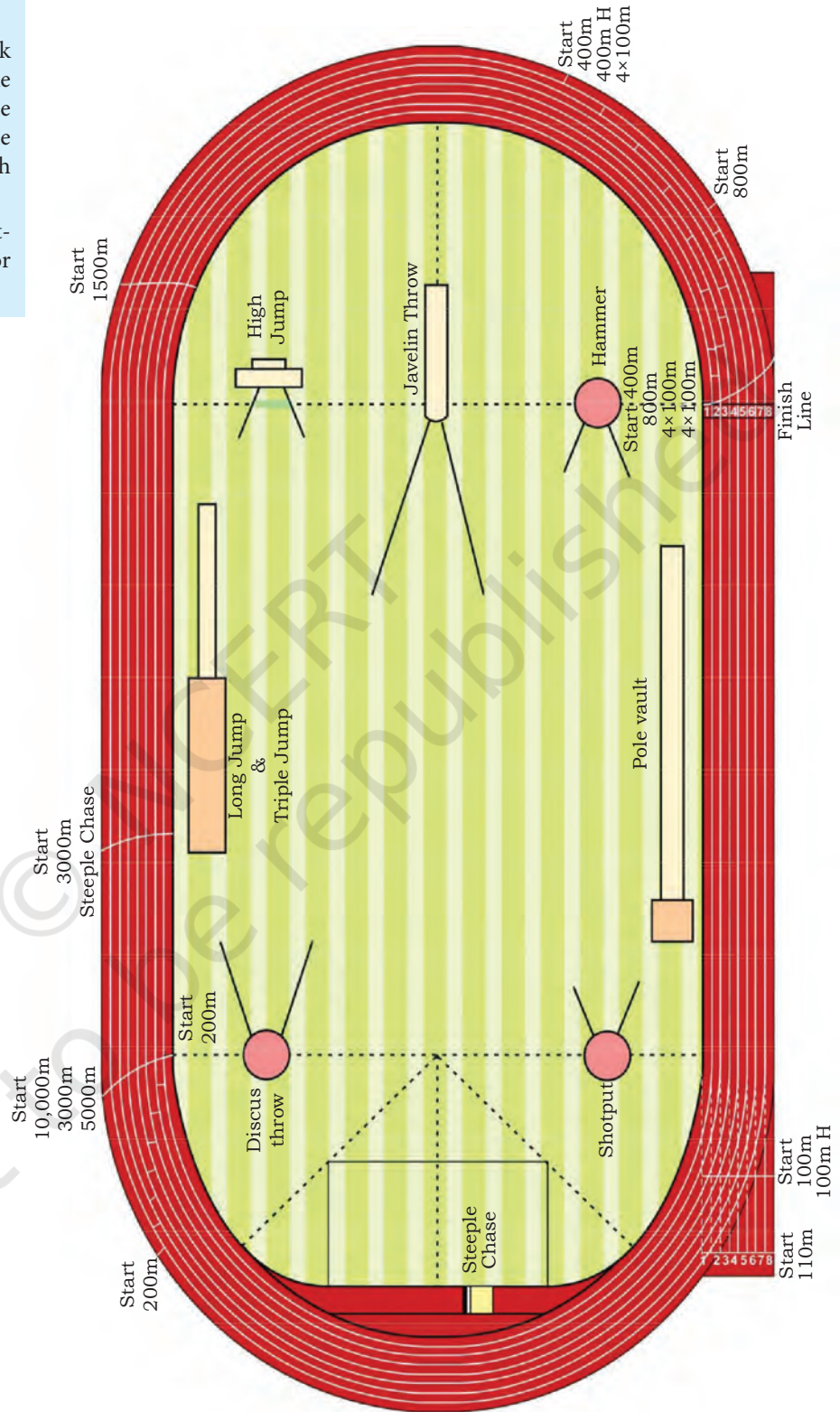

Fig. 4.1: Standard athletics track 400 meters

Types of Crouch Start

The crouch start is further divided into three types.

Bunch or Bullet Start

In such a start, the distance from the starting line to the block is between 16 to 19 inches. The distance between both the blocks (front leg and rear leg) may be 8 to 11 inches. The athlete sets the body in crouching position in such a way that the rear toe and the heel of front foot should be in a straight line. The toes should be behind the starting line like a bridge but in the line of big toe. In the set position, the hips should be slightly lifted up and the arms should be straight. This last position in the bunch start is a little unstable which helps the athlete in leaving the block quickly.

Medium Start

The distance of the blocks from the starting line is 15 to 18 inches. The distance between both the blocks (front leg and rear leg) may be 15 to 20 inches. The knee of rear leg and the arch of front foot should be in a straight line. The shoulders and hips are almost at the same height.

Elongated start

The distance of the blocks from the starting line is 11 to 14 inches. The distance between both the blocks (front leg and rear leg) may be 25 to 29 inches. The rear knee is placed near the front heel. In the crouch start, the distance between the blocks depends upon the length of the leg, breadth of the hip, length of torso, strength of arms and time reaction, etc. Medium start is considered as better than the other two starts. Most of the athletes, therefore, use this type of start.

The distance between the blocks (front and rear leg) varies and depends on the height of the athlete.



Fig. 4.2: Types of crouch start

Starting block

An athlete uses starting block in track events for all the sprinting ability to get a good start. The starting block helps the athlete to give support during the start of race to expel the body forward. Starting block needs to be kept in right angle according to

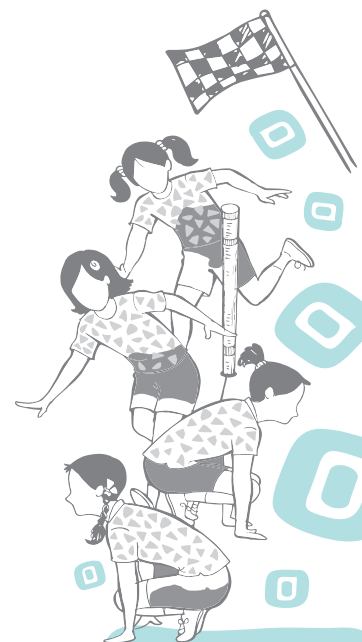

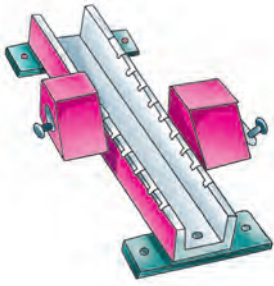

Fig. 4.3: Starting block

the height of the athlete. A starting block needs to be strong and adjustable.

Before starting, the athlete should be calm and composed. The athlete should wait for the commands while standing near the assembly line.

On Your Marks

On the command 'On your marks', the athlete will move towards the starting line and will take position at the starting block. The head is kept in resting position. In this position, the hand will be placed parallel to but behind the starting line and according to the width of the shoulders. The weight of the body is distributed on the rear knee and hands. In the starting position, the shoulders can be moved ahead of starting line. The neck should be in resting position but the concentration of athlete should be towards the next command.



Fig. 4.4: Both side views of the 'on your marks' position

Set

Athlete keeps the back a little above the shoulder. The weight of the body is equally distributed over the front foot and hands. This last position is usually unstable and tense which helps in leaving the block easily. Head should be in resting position and the grip on the block should be strong. The athlete should be alert enough to listen to the next command.



Fig. 4.5: 'Set' position



Gun shot

Soon after the gun shot, the athlete has to leave the block as quickly as possible. This helps in a good start. The athlete should lift his body gradually after taking a start.

Types of Finishing

The finishing of all the races is very important. A little difference can alter the athlete's ranking. The following techniques during training process need to be learned to finish the race.

Lunging forward

In this technique, the athlete lunges the body forward just before the finishing line. The athlete needs to spread arms backward in order to expand the chest forward. While spreading his arms the athlete needs to balance his body.

Shoulder shrug

In this technique, the athlete needs to bend shoulders towards the finishing line. The body weight is carried forward while maintaining the balance of the body. While shrugging the shoulders, the athlete needs to bend his head as well as upper body towards the finishing line.

Run through

This technique is usually adopted by new athletes. The athlete runs through the finishing line after completing the race. The athlete should not reduce the pace before finishing.

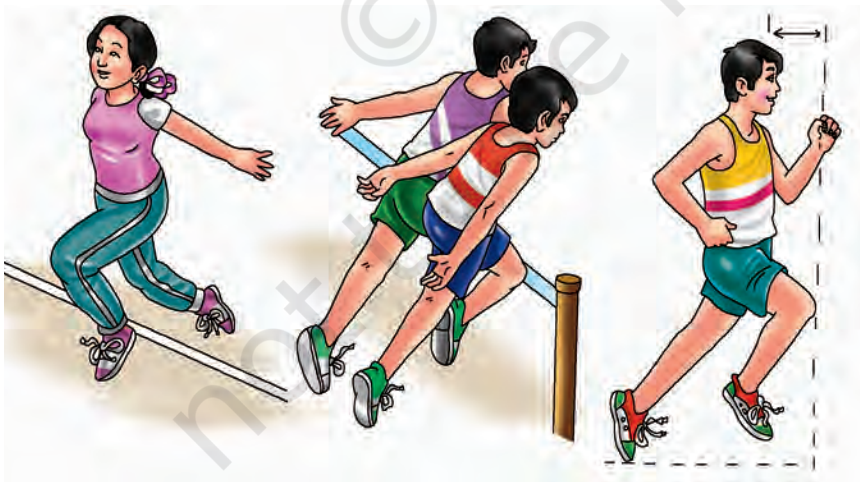
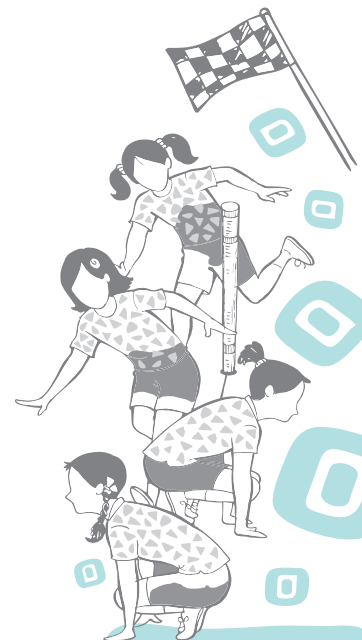

Fig. 4.6: Techniques of finishing the race

Relay Races

Relay races are team events. In this race, four runners complete a given distance. Each relay team needs four runners. Each runner runs the quarter of the running track, while holding



Do You Know?

Steeple chase—A hurdle race with water jumps came into existence in England around 1850.

a baton. Two runners will exchange the baton only in a given exchange zone mark in track. If the baton falls in the exchange zone, then only the athlete who has dropped it will lift it.

Table 4: Types of Relay Races

Relay Races for Men and Women
4×100 meter
4×400 meter
Members of Relay team = 6
Running members = 4
Length of Baton 28–30 cm
Circumference of Baton 12–13 cm
Weight of Baton at least 50 gms
Baton exchange zone 20 m
Acceleration zone 10 m

Methods of baton exchange

There are three methods of baton exchange, which are—

Downward pas

Fig. 4.7: Method to give the baton from the bottom

In such a pass, the runner who is to run will move his hand back to take the baton with palms facing upwards. The thumbs will be towards the inner side and the palm will be upward. The athlete holding the baton, will hold the baton from one end and will place the other end of the baton in the

hands of the athlete who is about to run.

Upward pass

In such a pass, the athlete who is going to hold the baton will keep the hand in a 'V' shape, which will be used to take the baton near the hip, upside down. The athlete who is passing the baton will hold the baton in such a way, that it will get nearer to the other athlete. This pass is easier for the new runner.



Fig. 4.8: Method to give the baton from the upper side

Push pass

Push pass is exactly similar to the downward pass at the change over box. The athlete, who is holding the baton, runs while aiming at the elbow of the other athlete with the baton. The other athlete takes the baton with his arm moving backward.



Fig. 4.9: Method to give push pass

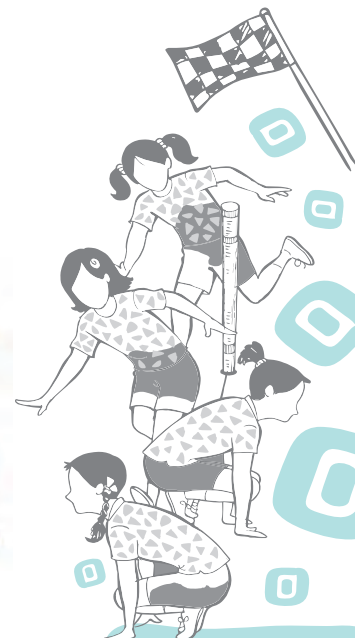

Jumping Events

Jumping Events consist of four events. However, only two (Long jump and High jump) are discussed below.

- Long Jump
- High Jump
- Triple Jump
- Pole Vault

Long Jump

Long jump is considered as the main field event. In this event, the athlete has to jump from the takeoff board to the jumping pit. The entire group of athletes will get three jumps to qualify for the final phase of the competition. Athletes should have speed, power and flexibility for it. Eight qualified jumpers are selected for the final phase of the competition. Three more chances are given to the selected eight jumpers for getting final ranking.

Table 5: Information about Long Jump

Length of runway	40 m – 45 m
Width of runway	1.22 m + 0.01 m
Length of take-off board	1.22 m + 0.01 m
Width of take-off board	20 cm
Thickness of take-off board	10 cm
Distance of the last edge of pit from take-off board	Minimum 10 m
Width of pit	2.75 m – 3.00 m
Distance of take-off board from the pit	1.00 m – 3.00 m
Width of plasticine indicator	10 cm
Degree of plasticine indicator towards runway	45°

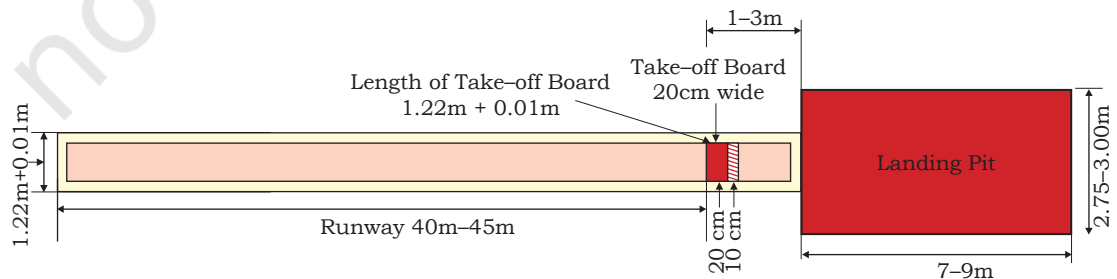

Fig. 4.10: Long jump ground

Methods of Long Jump

Athletes usually use the following methods for long jump—

1. Sail Technique
2. Hang Technique
3. Hitch-kick Technique

Phases of Long Jump

There are the four phases in long jump.

Runway: The athlete attains his maximum speed by running on the runway so that he can reach the take off board with full speed and also to get the maximum momentum.



Fig. 4.11: The hang technique

Take-off: The athlete takes-off with his strong foot by pushing it against the take-off board. The athlete raises both the hands up and as a result his entire body is raised up. The front leg is lifted upwards and the knee is bent.

Flight: When the body of the athlete is in the air after the take-off, it is known as flight. During flight position, the athlete uses various techniques like hang method or hitch-kick technique. The momentum gained during the runway helps the body to move forward in the air.

Landing: Both feet of the athlete simultaneously touch the ground while landing. During landing, the legs should be kept straight. Both hands should be raised and taken towards the feet and the neck should be bent forward. This posture helps in gaining some more distance in the air and the body gets balanced while landing.

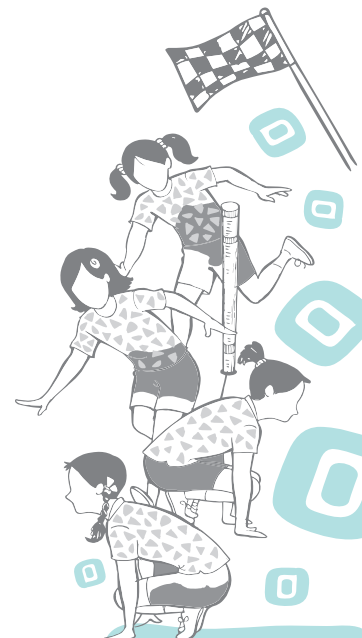



Fig. 4.12: Hitch-kick technique

High Jump

This is also one of the major field events. In this, the athlete crosses the crossbar with a jump. Activeness and flexibility are important for the athlete.

Table 6: Information about High Jump

Minimum length of runway	15 m
Size of landing area	6 m×4 m
Height of landing pit	0.60 m – 0.70 m
Distance between two poles	4.00 m – 4.04 m
Length of crossbar	4.00 m (±2cm)
Weight of crossbar	2 kg
Diameter of crossbar	29 mm – 31 mm
Length of rectangular edges of crossbar	15 cm – 20 cm
Width of edges of crossbar	30 mm – 35 mm
Gap between the edges of crossbar and poles	10 mm

Techniques of High Jump

The most popular technique of high jump is Fosbury Flop. However some other techniques are also used. Which are—

Scissor Jump: To jump over the crossbar with alternate legs and to land on the feet is called scissor jump.

Western roll : Rolling over the crossbar and landing on the back is known as western roll.

Straddle Technique: In this technique, the legs are taken alternately over the crossbar and the body is rolled near the bar.

Fosbury Flop: It is a new technique. In this, the bar is crossed by back after bending the body. The landing is done on the shoulders.

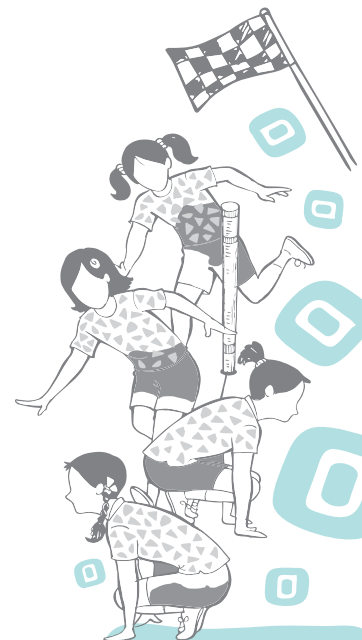

Fig. 4.13: Fosbury flop

General Rules

Certain general rules of high jump are given below.

- Jumper needs—to jump on one foot only.
- It will be a foul, if an athlete—
 - shakes the bar from the support.
 - touches the ground with any part of his body before clearing the poles.
- An athlete can jump from any height. Consecutive three failures from a particular height will disqualify the athlete.
- Poles should not be moved during the competition.
- If there are more than three athletes, the time fixed for each jump is one minute. If two to three athletes are there in the competition, time of 1.30 minutes is given. Whereas a time of 3 minutes is given to a single athlete.



- Athlete can mark the runway according to the wish, but can use only the adhesive tape given by the organisers.



Fig. 4.14: Complete action sequence of fosbury flop

Throwing Events

The following four events are not included in the throwing events, but only two (Shot put and Discus) are explained in this book.

- Shot put
- Discus

Shot put

Table 7: Information about Shot Put

Diameter of the shot put circle	2.135 m (± 5 mm)
Extended lines on both sides of the circle	75 cm
Length of stop board	1.21 m (± 0.01 m)
Width of stop board	11.2 cm – 30 cm
Height of stop board	10 cm (± 0.2 cm)

Weight of shot	7.260 kg (for men), 4.00 kg (for women)
Diameter of shot	110 mm – 130 mm (men) 95 mm – 110 mm (women)
The extended lines on both sides of the circle	75 cm
Angle of the throwing sector within the circle	34.92°

Shot put is one of the main throwing events. The athlete who throws the shot is called as shot putter. The athlete should have qualities like power, flexibility and speed to throw the shot.

Methods of Shot put

The following are the methods of shot put.

1. Gliding Technique

- a) Grip: The shot is held at the base of the fingers, not the palm. Fingers are slightly spread apart with the thumb for support. The hand will be bent back in a cocked position when holding the shot.
- b) Shot placement: The shot is placed below the ear. It needs to be placed near the jaw bone and over the collar bone.
- c) Standing Position: The shot putter places the right foot on the half way circle line and the left foot along the back line (towards the direction of throw) of the circle.
- d) Gliding Phase: Keep the right foot exactly straight and the toe of the left foot touching on the ground just in front of the stop board. The left foot will rapidly move forward while bending at the knee to take thrust from the hip joint. The right foot will be dragged from the ground.
- e) Final Phase: The last phase of the putting shot will be associated with the turn of body and changing of rear left foot to right for balancing the body weight. The hips will be carried forward. This turn is most vital for the shot putter as it has to be combined with the throwing of arms to put the shot for distance. The whole body weight will be maintained on right foot after the release of shot.

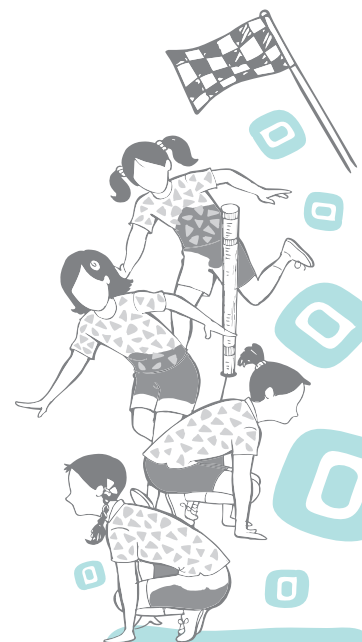

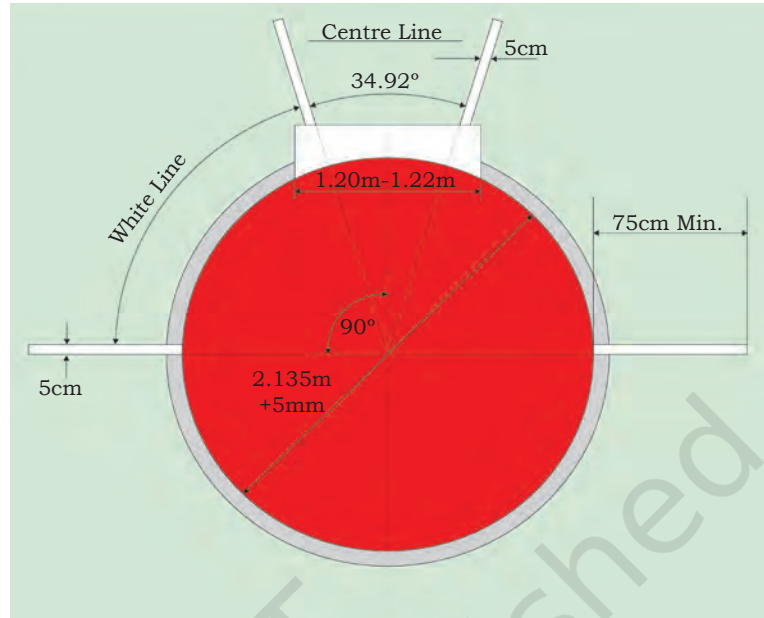

Fig. 4.15: Layout of shot put sector



Fig. 4.16: Gliding technique for throwing shot

2. Rotation Technique for Throwing Shot

- Initial Position:** In the initial position, the athlete will stand with the back towards the direction of putting the shot. The left foot will be on central line and the right foot will be just behind. The right foot will be 5–8 cm behind the iron rim to avoid foul during rotation of the body.
- Rotation:** The weight of the body will be on the right foot. Rotation will start after taking just one swing from the starting position. In this position, the left arm will be kept parallel to the ground on left side.

The right foot will be brought over the left foot while leaning the shoulder when the shot reaches the middle. Both the shoulders will rotate after leaning and laying the entire body weight on the toes. The shoulder and the trunk will fully rotate towards the right and the body weight will also shift on the left foot.

Discus Throw

Discus throw is an old and popular event. The athlete should have power, elasticity, speed and balance for discus throw.

Table 8: Information about Discus Throw

Weight of discus	2 kg (men), 1 kg (women)
Diameter of discus	219 mm – 221 mm (men) 180 mm – 182 mm (women)
Thickness of the rim of discus	12 mm – 13 mm (6 mm at edge)
Diameter of circle	2.50 m
Extended lines on both sides of circle	75 cm
Angle of throwing sector	34.92°

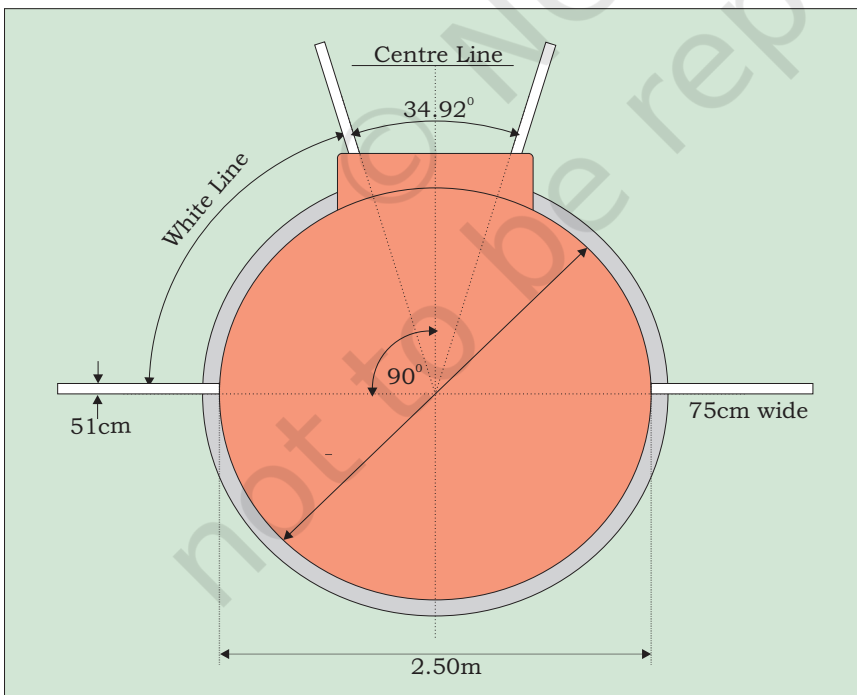
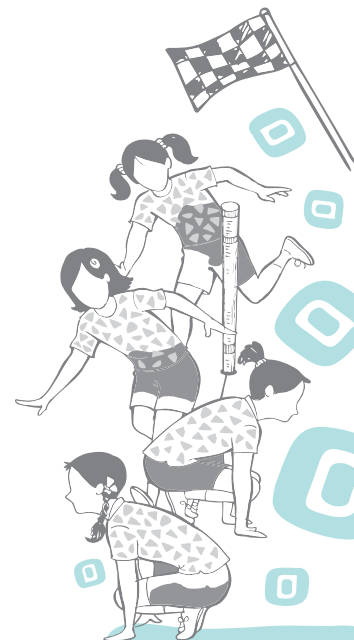

Fig. 4.17: Layout of discus throw



Do You Know?

The first national body of athletics 'Amateur Athletic Association, (AAA), was established in England.

Initial Stage of Discus Throw

At First the athlete will stand in the circle near the ring with the back against the direction of throwing the discus. The athlete will take one or two swings while rotating the right arm along with the body. In this position, the whole body weight will shift from one foot to another. The heels will lift upward. The upper part of the body should be bent towards right side, while the discus is on the right side. The circle will start from the lower part of the body, the left foot will be rotated leftward, and the body weight will rest on it. The right knee and right foot will also rotate.

In this position, the process of crossing the discus will start. First of all, the left foot will leave the ground. After this, the left foot will take the position of throwing the discus. The right foot (bent at knee) will rotate from left to right in a semi-circle. Both the muscles will be in front of the shoulder while rotating and as a result, there will be a bend in the upper and lower portion of the body. The right arm holding the discus will be straight and above the head. The left arm will be in front of the chest and bent at the elbow. The head will remain straight.

Methods of Discus Throw

A Discus is thrown by three methods.

1. The athlete keeps the right foot at the centre line and left foot 10 cm behind the circle.
2. In the second method the athletes keep the centre line between their feet.
3. In the third method, the athletes keep their left foot on the centre line.

Throwing: Both the feet will be straight at the knees while rotating at the time of throwing. The shoulder muscles will move forward. The shoulders and trunk will stop rotating. Whole of the body's weight will be on both the toes and feet will be straight. The left foot will come back at the end but the right foot will bend from the knee after going forward. The upper part of the body will be bent forward. It is done to balance the body.

Last Step: Both the feet will be on the ground, the waist will be bent backward in rotating position, left foot will be in straight line and right foot will be bent at knee. The right knee will be rotating to the left side. The left arm will open upward. The right arm will be brought forward and upward while keeping away from the body.





Fig. 4.18: Technique of throwing discus

Types of Sports Awards

There are many awards to honor the outstanding coaches and sportspersons. Government of India honors its coaches, and sportspersons with the following awards:

1. Dronacharya Award
2. Arjuna Award
3. Rajiv Gandhi Khel Ratna Award
4. Dhyan Chand Award

Dronacharya Award

Government instituted Dronacharya Award to recognise the efforts of coaches and trainers who dedicate their lives for enhancing the performance of athletes and raising the standard of games. The Dronacharya Award was first given in 1985. Every year, Dronacharya award is provided to expert coaches for their consistent outstanding performance. The cash prize associated with Dronacharya Award is ₹ 5 lakhs. It also includes a bronze statue of Guru Dronacharya (the ancient Indian Physical and weapon trainer in the mythological era of Mahabharata), a tie, a blazer, a scroll and a suit.

Eligibility for Dronacharya Award

The award is open to coaches who have trained an individual or a team for at least two years with consistent outstanding performance at:

1. Global Olympic events
2. Sports disciplines recognised by the government
3. Indigenous sports recognised by the government

Dronacharya Award Winners

Some of the well known coaches of athletics who received Dronacharya Award in India are—O.M. Nambiar (1985),

Do You Know?

Deepa Malik is the lady Para-athlete who received Arjuna Award in the year 2012 for her excellent performance.

Activity 4.4

Make a list of winners of Dronacharya Award for the last five years and share with other students.

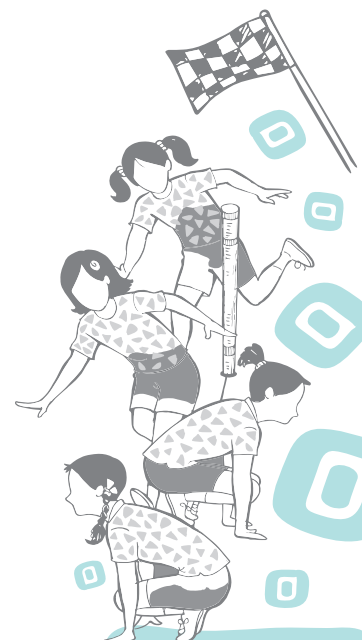

Activity 4.5

Collect information about the medal winners of Paralympics Games in any two athletic events who have received Arjuna Award and prepare a chart on their achievements to share on the school notice board.

Activity 4.6

Collect information about the Arjuna award and Dhyan Chand award winners. Prepare a chart on their achievements to share on the school notice board.

Ilyas Babar (1994), Karan Singh (1995), Joginder Singh Saini (1997), Hargobind Singh Sandhu (1998), Kuntal Roy, R.D. Singh (2006), A.K. Kutty (2010), Ramphal (2011), Mahavir Singh Phogat (Wrestling, 2016), and Sukhdev Singh Pannu (Athletics, 2008).

Arjuna Award

The Arjuna Award was instituted in 1961 as the highest national recognition for outstanding performance in Sports and Games in the Olympics, Asian Games, Commonwealth Games, World Cup, World Championships. As per the revised scheme, from April 2002, the objective of Arjuna Awards is to recognise outstanding performance of sports persons at international level. The winners are decided by a Selection Committee. The award carries a cash prize of ₹5 lakh, a bronze statuette of Arjuna, and a scroll. The nominations for the award are invited by the Ministry of Youth Affairs and Sports from all recognised National Sports Federations recognised by the Government of India.

Arjuna Award Winners in Athletics

Some of the well known athletes who received Arjuna Award in India are Gurbachan Singh Randhawa (1961), Ajmer Singh, (1966), Vijay Singh Chauhan (1972), Sriram Singh (1973), T.C. Yohannan, (1974), Hari Chand, (1975), Sabir Ali (1981), P.T. Usha (1983), Shiny Abraham (1984), Anju Bobby George, (2002). Hima Das, Neeraj Chopra (2018).

Rajiv Gandhi Khel Ratna Award

The Rajiv Gandhi Khel Ratna award is India's highest honour given for achievement in sports. The words *Khel Ratna* in Hindi literally mean "sports gem" in English. It carries a medal, a scroll of honour and a substantial cash component of ₹ 750,000. The award was instituted in the year 1991-92 for supreme accolade in the field of sports in India. The first player to receive the Rajiv Gandhi Khel Ratna award was Anand Viswanathan, World Chess Champion.

Rajiv Gandhi Khel Ratna Award Winners in Athletics

Some of the winners of Rajiv Gandhi Khel Ratna award are Jyotirmoyee Sikdar (1998-99), K.M. Beenamol (2002-03), Anju Bobby George (2003-04).

Dhyan Chand Award Winners in Athletics

Dhyan Chand Award is given for lifetime achievement in sports. The award is named after Dhyan Chand, an Indian field hockey player who scored more than 1000 goals during his career from 1926 to 1948. Bobby Aloysius received the



Dhyan Chand award for his lifetime contribution towards sports from the Government of India.

BADMINTON

Badminton, one of the world's fastest racket sports is a popular school sport for both boys and girls. It is suitable for children of all ages and abilities. Badminton activities develop all-round physical skills important for school age children including eye-hand coordination, catching and throwing, stability and balance, speed and agility—the ability to quickly change direction, jumping and landing skills, and also learn decision-making and tactical skills. Badminton was earlier known as Poona or Poonah when British Army officers started playing the game at Pune in 1860. The name Badminton derives from the Duke of Beaufort's Badminton House in Gloucestershire. International Badminton Federation (IBF) is the international governing body for Badminton and was established in 1934. The new name Badminton World Federation (BWF) was adopted in 2006. Thomas Cup, a Men's Team World Badminton Championship, was first held in 1948, and Uber Cup, a Women's Team World Badminton Championship, was first held in 1956. Sudirman Cup, a World Mixed Team Badminton Championship, was first held in 1989. Individual World Badminton Championship started in 1956. Badminton was a demonstration event in the 1972 Munich Olympic Games and an exhibition sport in the 1988 Summer Olympics. It became an official Summer Olympic sport at the Barcelona Olympics in 1992.

Types of Events

- Men's and Women's Singles, Doubles, Mixed Doubles
- Junior Boy's and Girl's (Under 17 and 19) Singles, Doubles, Mixed Doubles
- Sub Junior Boy's and Girl's (Under 13 and 15) Singles, Doubles, Mixed Doubles

Measurement of Badminton Court and Specification of Equipment

- Badminton is an indoor game. It requires a racket, a net, two posts and a shuttlecock.

Court Measurements

Badminton court is rectangular, 13.40×6.10 metre (5.18 metre for singles) with 4 cm wide white or yellow lines. The height of the ceiling from the court for International competitions shall be 12 metre. There shall be at least 2 metre clear space surrounding the court. The posts shall be 1.55 metre in height

Activity 4.7

Do you have indoor badminton hall in your school or nearby? if yes, collect the information about the game and compare with the information given in your book.

Activity 4.8

Collect information about the Olympic Medalists and All England winners of your country in badminton.

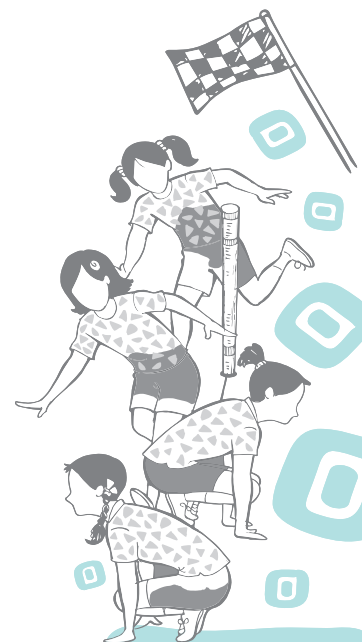

from the surface of the court and placed on the doubles' side lines. Net shall be of dark colour with its height 1.524 metre at the centre. It is 76 cm in depth and at least 6.10 metre in width. The shuttle shall have 16 feathers fixed in the base and weigh from 4.74 to 5.50 grams. The racket shall not exceed 680 mm in overall length and 230 mm in overall width.

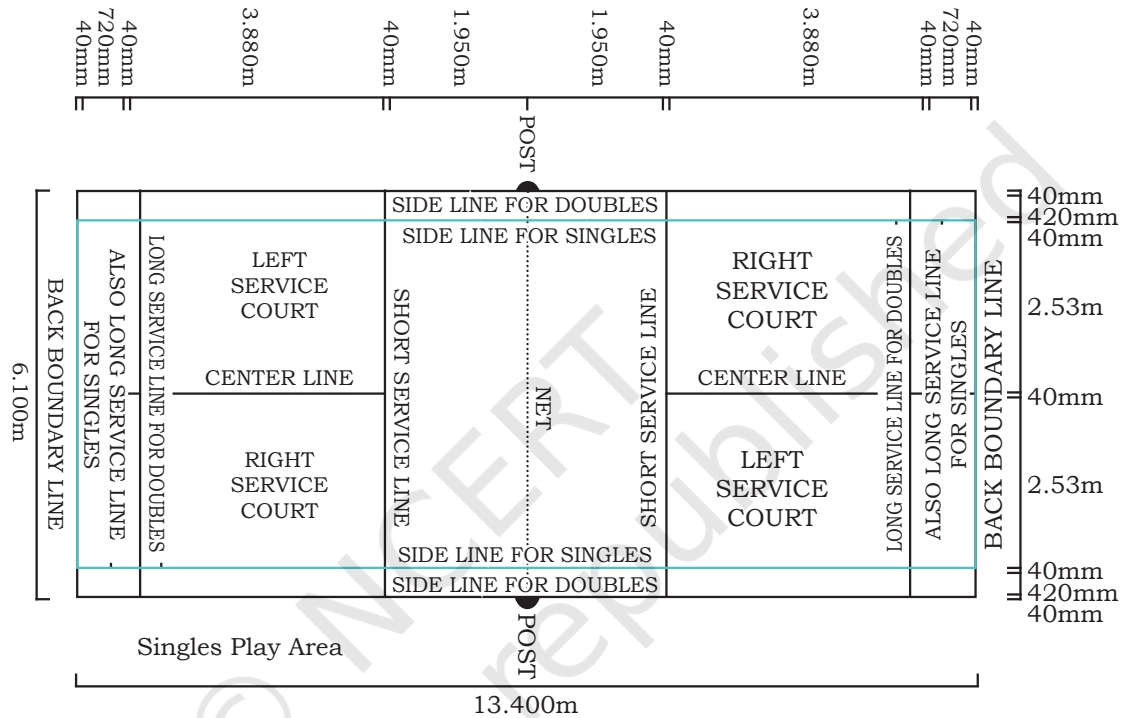

Fig. 4.19: Badminton court

How to play Badminton

For playing Badminton, the following process is followed:

- The toss is conducted before the play starts.
- The side which wins the toss can choose either to serve or receive first and at which side of the court to play.
- To start the game, the server delivers the service by hitting the shuttle with the racket below the waist in the diagonally opposite service courts.
- During the service, it is considered as a 'fault':
 - if the shuttle is caught on the net and remains suspended on its top if or
 - after passing over the net, the shuttle is caught in the net; or
 - if the served shuttle is hit by the receiver's partner.

Fig. 4.20: Badminton racket and shuttle

- It shall be a 'fault' during play if;
 - the shuttle lands outside the boundaries of the court, or
 - it fails to pass over the net, or
 - it touches the ceiling or side walls, or
 - it touches the player or the dress of a player.

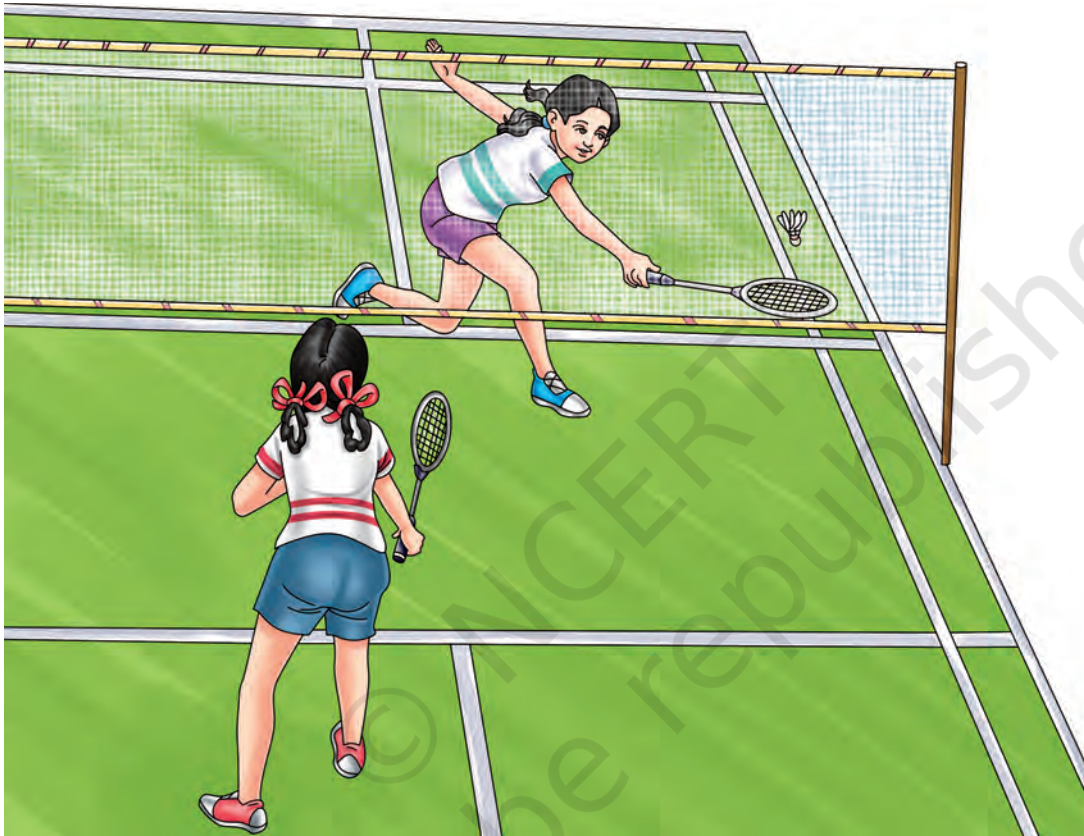

Fig. 4.21: Singles game

Singles

- At the beginning of the game (0–0)
- When the server's score is even, the server serves from the right service court.
- When the server's score is odd, the server serves from the left service court.
- If the server wins a rally, the server scores a point and then serves again from the alternate service court.
- If the receiver wins a rally, the receiver scores a point and becomes the new server.
- The player needs to serve from the appropriate service court—left if their score is odd, and right if the score is even.

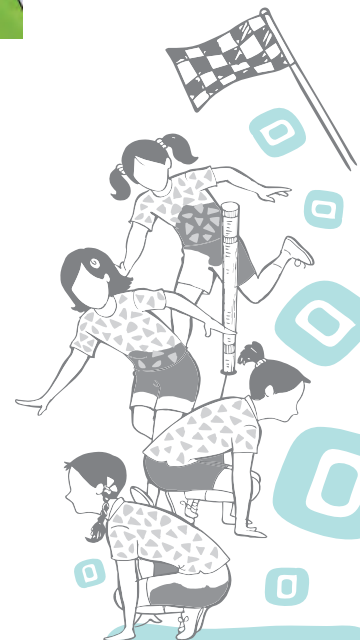



Fig. 4.22: Doubles game

Do You Know?

During a game of badminton, a shuttlecock hit by the player may reach a speed of more than 2000 miles per hour.

Doubles

- A side has only one 'service'.
- The service passes consecutively to each player.
- At the beginning of the game and when the score is even, the server serves from the right service court. When it is odd, the server serves from the left court.
- If the serving side wins a rally, the serving side scores a point and the same server serves again from the alternate service court.
- If the receiving side wins a rally, the receiving side scores a point. The receiving side becomes the new serving side.
- Players do not change their respective service courts until they win a point when their side is serving.

Scoring System

- A match consists of best of three games of 21 points each.
- Every time there is a serve, there is a point scored.

- The side winning a rally adds a point to its score.
- At a score of 20 all, the side which gains two-points lead first wins that game.
- If the score reaches 29 all, the side scoring the 30th point, wins that game.
- The side winning a game serves first in the next game.
- When the leading score reaches 11 points, players have a 60 seconds interval.
- An interval of two minutes is allowed between each game.
- In the third game, players change ends when the leading score reaches 11 points.

Fundamental Skills of Badminton

Basic Strokes

A wide range of strokes are used in badminton. The services are—

- (i) High Serve
- (ii) Backhand Low Serve
- (iii) Backhand Flick Serve
- (iv) Forehand Low Serve
- (v) Forehand Flick Serve

Forecourt Strokes or Net Strokes

It is played from an area between the net and the short service line. These are named as—

- Backhand Net Shot
- Forehand Net Shot
- Backhand Net Lift
- Forehand Net Lift
- Backhand Net Kill
- Forehand Net Kill

Midcourt Strokes

Played from the middle of the court, these are called—

- Block
- Backhand Drive
- Forehand Drive

Rear Court Strokes

These are played from the back of the court.

- Forehand Clear
- Forehand Smash

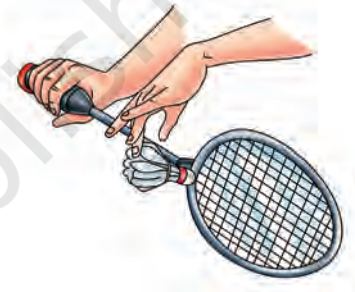
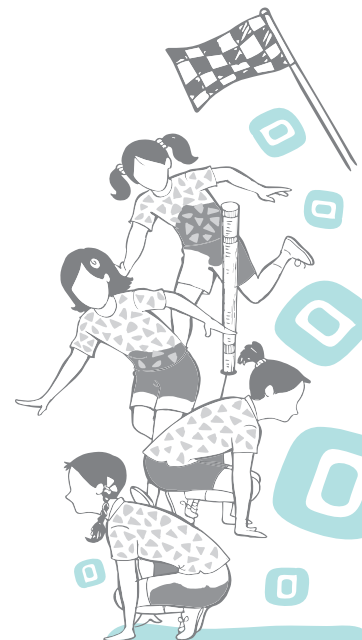

Fig. 4.23: Stance for backhand low and flick serve



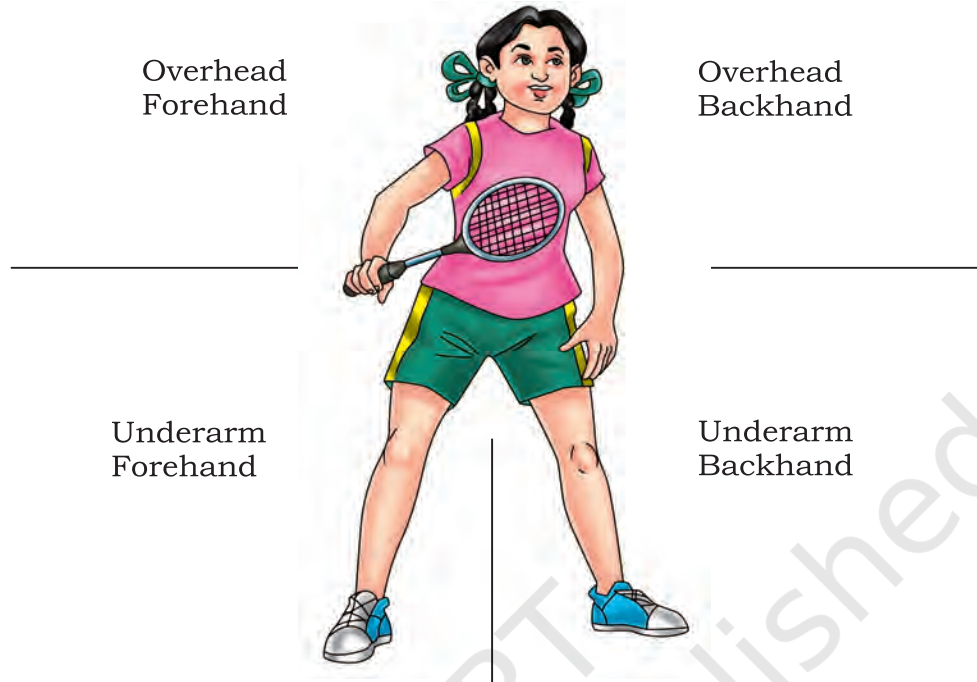

Fig. 4.24: Position marked for various strokes

- Forehand Drop Shot
- Backhand Clear
- Backhand Smash
- Backhand Drop Shot

High Serve

- High serve travels to the rear of the opponent's service court, dropping vertically.
- It is used in singles to begin the rally, from a neutral/defensive position.
- High serve is used in women's singles and sometimes in men's singles.
- A sideways stance is used with the racket held in forehand grip.
- The racket and shuttle are held in elevated position with weight on the rear leg.
- Weight is continuously transferred forward towards the front foot and the shuttle is dropped to the side or in front.
- The racket is lowered with bent wrist and swung forward by accelerating the racket head to hit the shuttle in front and to the side of the body.
- The racket is carried through high and long in follow through.



Backhand Low Serve

- Backhand Low Serve is used in doubles and men's singles to start the rally from a defensive or neutral situation.
- In backhand low serve, the shuttle skips the net and lands at the front of the opponent's service court.
- It is used to restrict the opponent's opportunity to attack and create attacking opportunities for the serving side.

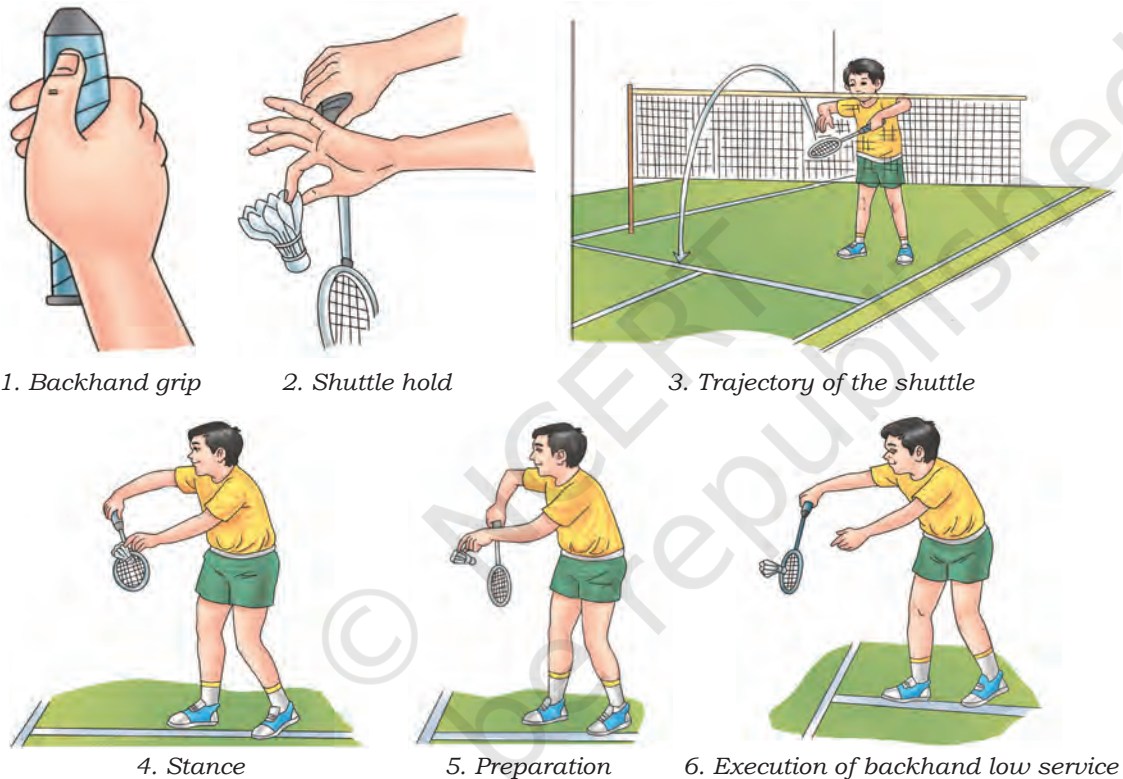
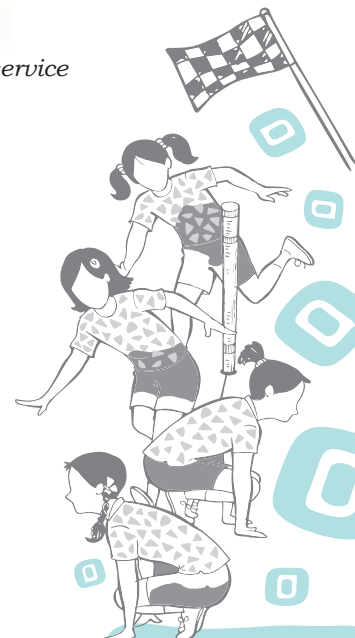

Fig. 4.25: Backhand low serve

- The server stands with the racket, foot forward, close to the 'T' on the court.
- The racket is held in relaxed backhand grip in front of the body, with the shuttle placed on it.
- With the short backswing of the racket, its face is opened slightly.
- The racket is swung forward and the shuttle is pushed out of the hand.
- Strike the shuttle out of the hand with a continued pushing action.
- Quickly recover back by bringing the racket up, to return the service reply.



The main difference in high, low and flick service in badminton is the trajectory of the shuttlecock. Trajectory is the parabolic path followed by a shuttle when hit at a certain angle.

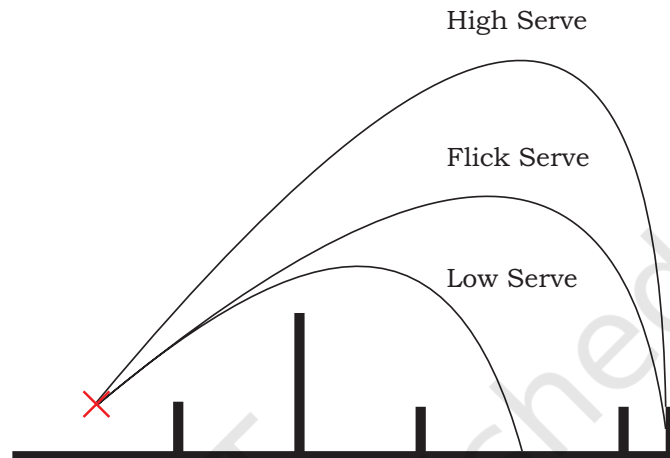

Fig. 4.26: Trajectory of services

Do You Know?

- The word Gymnastic is derived from the Greek word Gymnos meaning 'naked art'.
- Modern Gymnastic is regulated by Federation International de Gymnastique (FIG), which was founded in 1881, June 23.
- Khushi Ram and Veer Singh represented India for the first time in Olympics held at Helsinki in 1952.

GYMNASTICS

History

Gymnastics begun in ancient Greece about 2500 years ago. It was used in training to keep people fit for sporting activities. In the Greek city of Athens, gymnastic tournaments were held, including tumbling, rope climbing, and other similar activities. Plato, Homer and Aristotle strongly advocated the strengthening qualities of gymnastics. The 'Federation of International Gymnastics' (FIG) was formed in Liege in 1881.

Gymnastics in India

Gymnastics Federation of India (GFI) was initiated in 1951. It was affiliated by the Indian Olympic Association (IOC) and Federation International de Gymnastics (FIG) in 1952. GFI is the founder member of Commonwealth Gymnastics Confederation (CGC) and Asian Gymnastics Union (AGU) since these bodies came into existence. The National Gymnastic Championship for men and women was organised in 1952 and in 1962 respectively. The first national championship for sub junior girls and boys was organised in 1986 at Karnal in Haryana. Sports Aerobics was also organised under Gymnastics Federation of India from 1997 along with gymnastics.



Apparatus

You have already studied in previous classes about gymnastics. In this game, different events are performed on different apparatuses like Horizontal Bar, Parallel Bars, Rings, Vaulting Table, Pommel Horse and some other apparatus specially for female participants like, un-even bars, balancing beam, etc.

Gymnastics is performed by both men and women. Men have six apparatus and women have four apparatus on which they perform their routines. Their apparatuses are as follows:

Women's apparatus

- | | |
|-------------------|-------------------|
| 1. Vaulting Table | 2. Balancing Beam |
| 3. Floor exercise | 4. Uneven Bars |

Men's apparatus

- | | |
|-------------------|-------------------|
| 1. Vaulting table | 2. Horizontal Bar |
| 3. Floor exercise | 4. Parallel bars |
| 5. Roman Rings | 6. Pommel Horse |

Uneven Bars

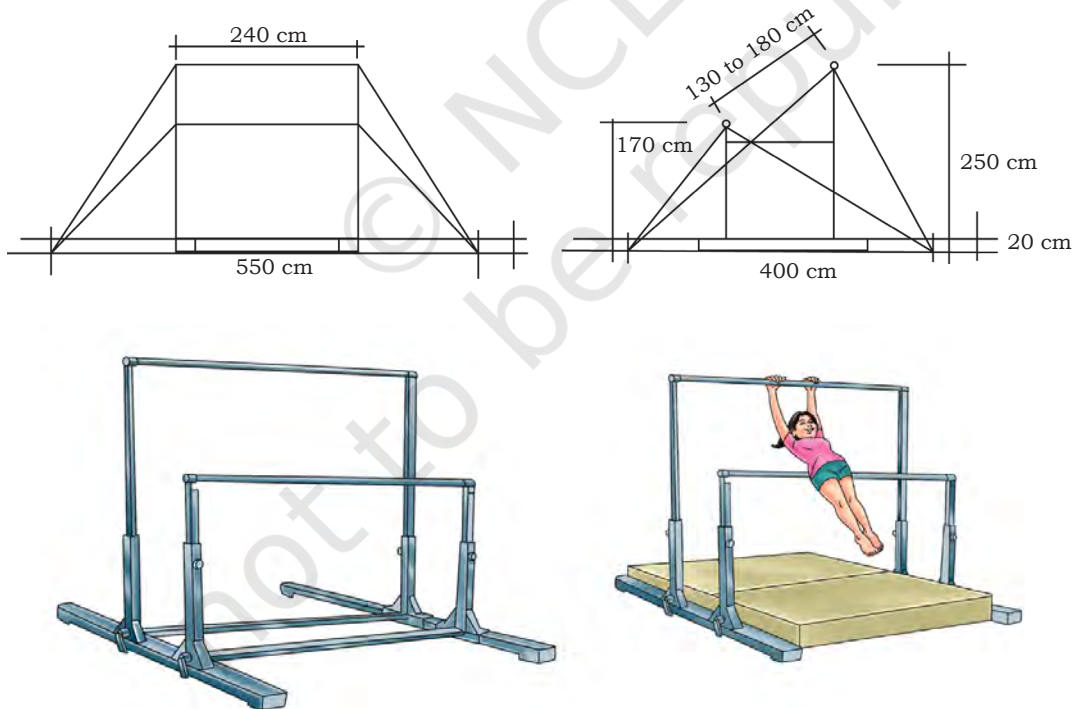
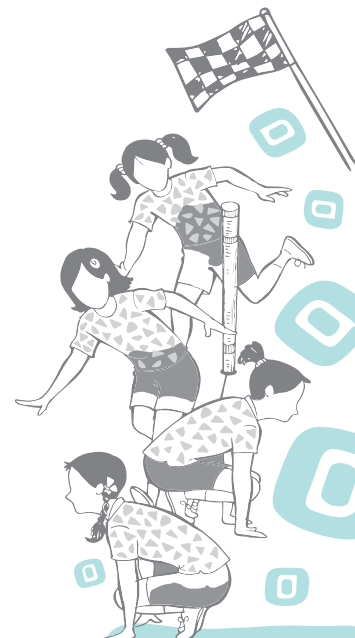

Fig. 4.27: Uneven bars

Do You Know?

- Nadia Comaneci was the first female gymnast who received perfect score in 1976 at Montreal Olympics.



Specifications

- Height: Upper bar—2.50 m (8.2 ft), Lower bar—1.70 m (5.6 ft)
- Diameter of the bar: 4 cm (1.6 in)
- Length of the bars: 2.10 m (7.9 ft)
- Diagonal distance between the two bars: 1.30 m (4.3 ft)–1.90 m (6.2 ft) (adjustable)

Horizontal Bars

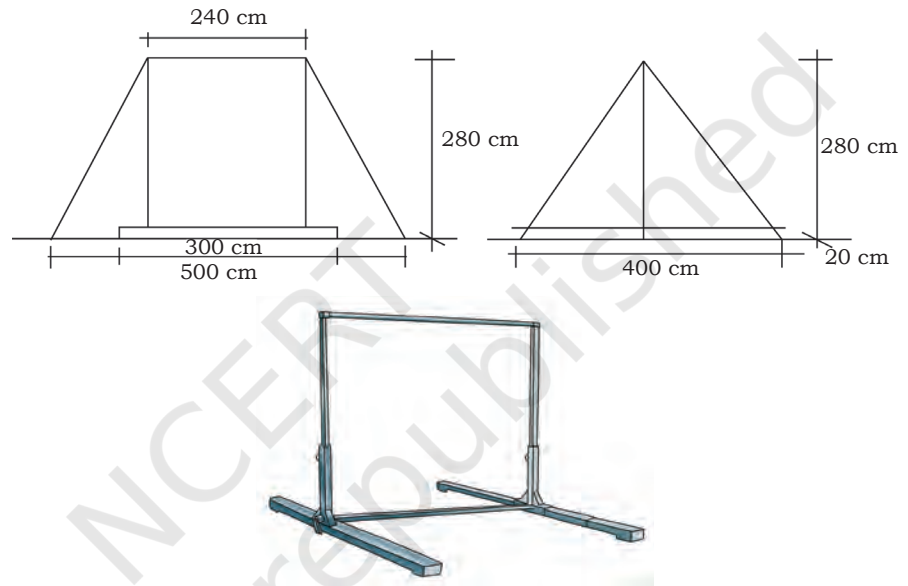
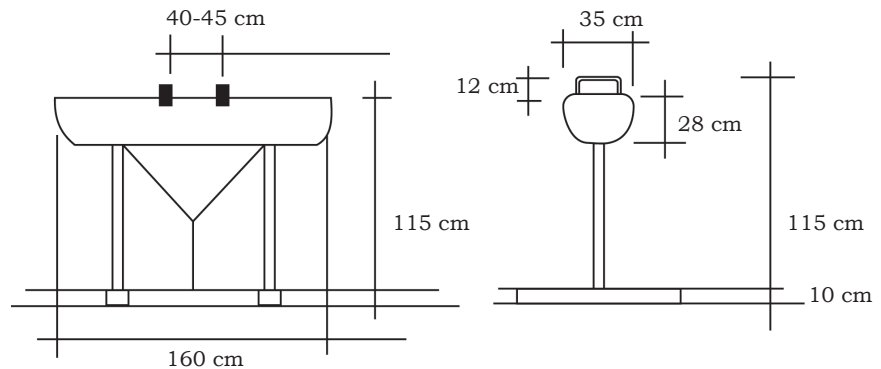

Fig. 4.28: Horizontal bars

Specifications

- Height: 2.80 m (109 in), including about 30 cm (12 in) landing mats
- Length: 2.40 m (94 in)
- Diameter of the bar: 2.8 cm (1.1 in)

Pommel Horse



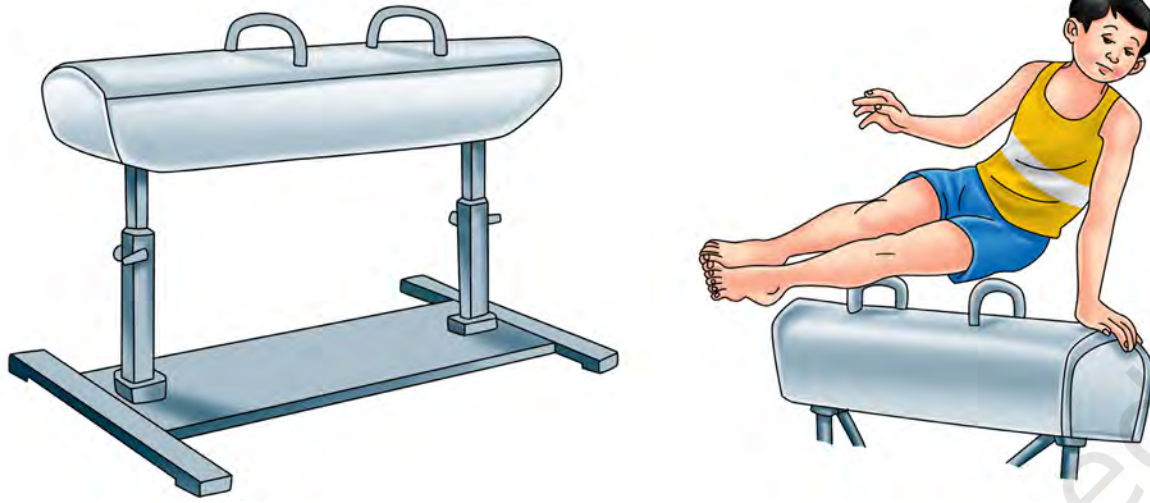
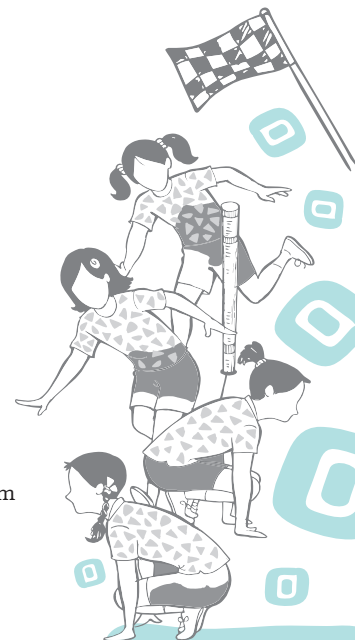
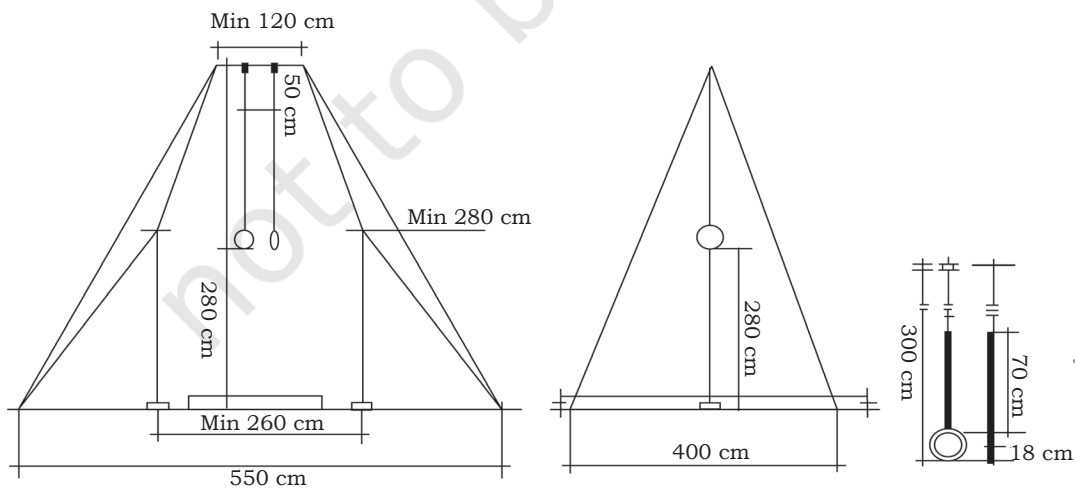

Fig. 4.29: Pommel horse

Specifications

- Height from top surface to floor: 1.15 m (3.77 ft) \pm 1 cm (0.39 in)
- Length at top: 1.60 m (5.2 ft) \pm 1 cm (0.39 in)
- Length at bottom: 1.55 m (5.09 ft) \pm 1 cm (0.39 in)
- Width at top: 35 cm (14 in) \pm 1 cm (0.39 in)
- Width at bottom: 30 cm (12 in) \pm 1 cm (0.39 in)
- Height of the pommels: 12 cm (4.7 in) \pm 0.5 cm (0.20 in)
- Distance between the pommels: 40 cm (16 in)–45 cm (18 in)(adjustable)

Roman Rings



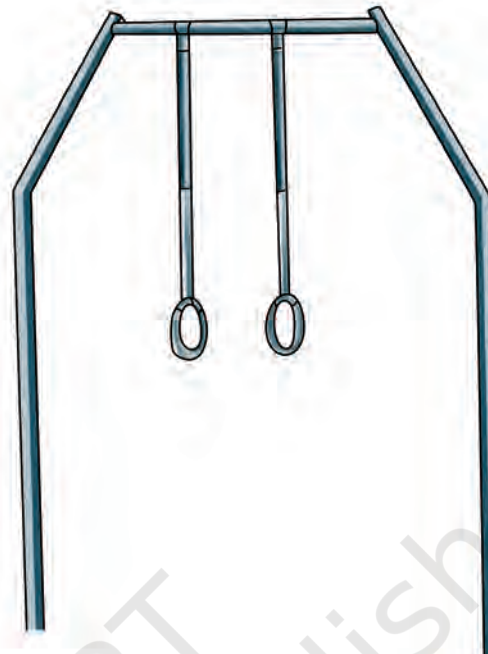

Fig. 4.30: Roman rings

Specifications

- Inner diameter: 18 cm (7.1 in) \pm 0.1 cm (0.039 in)
- Diameter of profile: 2.8 cm (1.1 in) \pm 0.1 cm (0.039 in)
- Distance from the point of attachment to lower inner side of the rings: 3 m (9.8 ft) \pm 1 cm (0.39 in)
- Distance between the two points of attachment: 50 cm (1.6 ft) \pm 0.5 cm (0.20 in)

Vaulting Table (Men and Women)

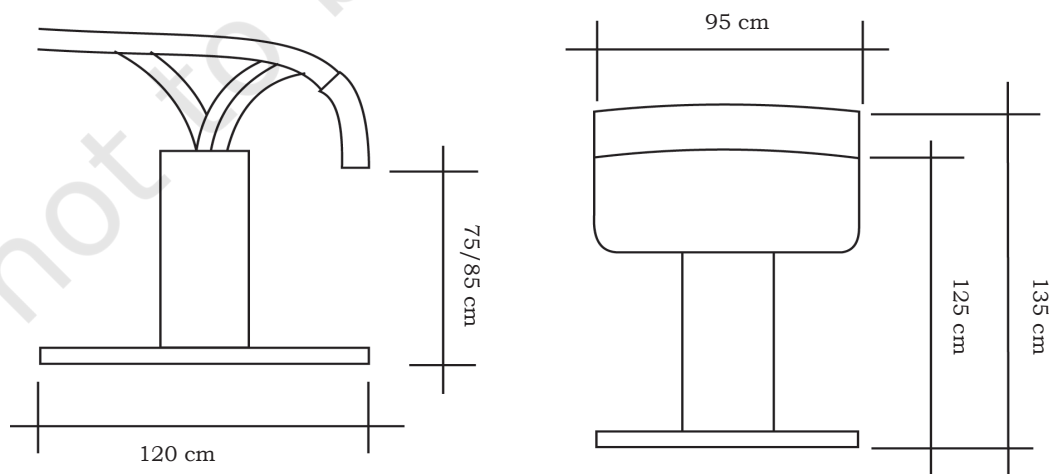



Fig. 4.31: Vaulting table

Specifications

- Length: 1.20 m (3.9 ft) \pm 1 cm (0.39 in)
- Width: 90 cm (3.0 ft) \pm 1 cm (0.39 in)
- Height
 - Men: 1.35 m (4.43 ft) \pm 1 cm (0.39 in)
 - Women: 1.25 m (4.10 ft) \pm 1 cm (0.39 in)
- Run up area
 - Length: 3.5 m (11.5 ft) \pm 10 cm (3.9 in)
 - Width: 1 m (3.3 ft) \pm 1 cm (0.39 in)

Balancing Beam

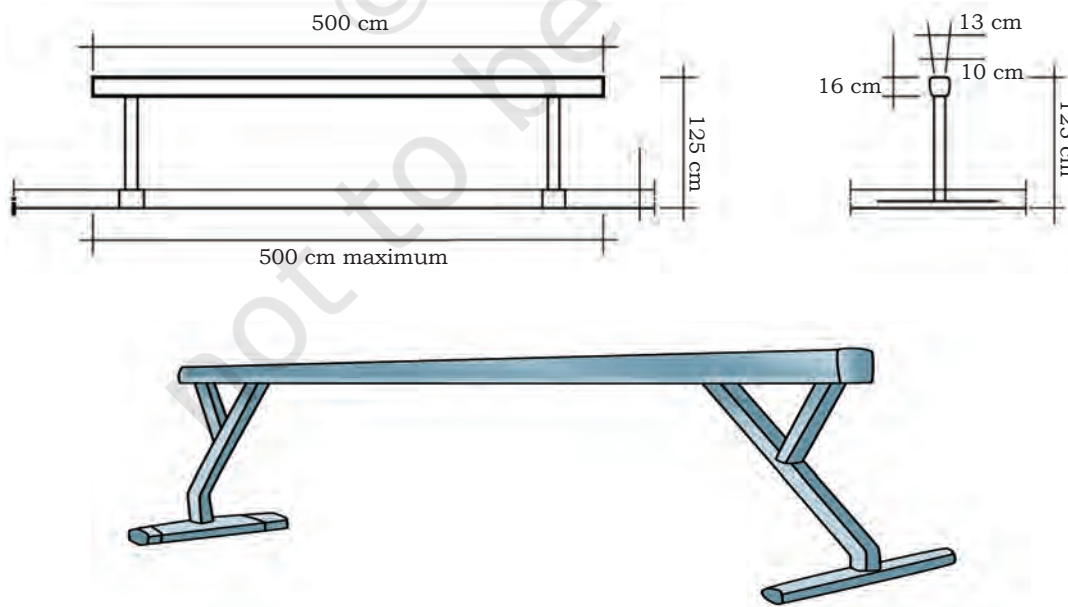
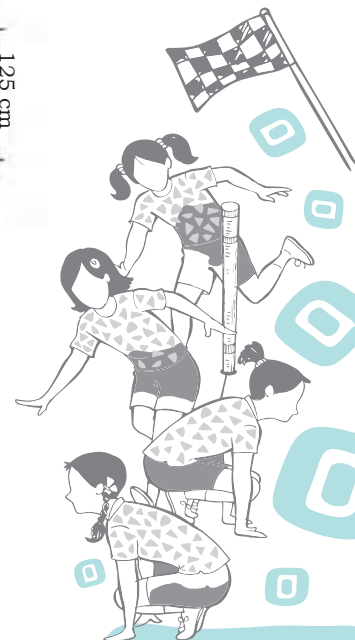

Fig. 4.32: Balancing beam



Specifications

- Height: 1.25 cm (4.10 ft)
- Length: 5 cm (16 ft)
- Width: 10 cm (3.9 in)

Floor

Fig. 4.33: Floor

Specifications

- Performance area: 12 m (39 ft) × 12 m (39 ft) ± 3 cm (1.2 in)
- Diagonals: 1.697 m ± 5 cm (2.0 in)
- Border: 1 m (3.3 ft)
- Safety zone: 2 cm (6.6 ft)

Parallel Bar

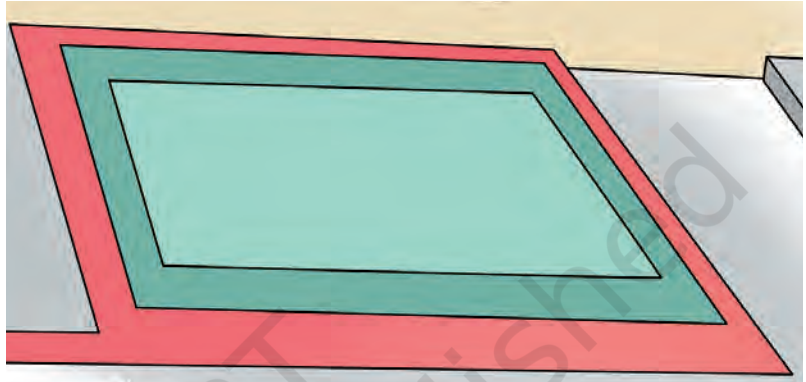
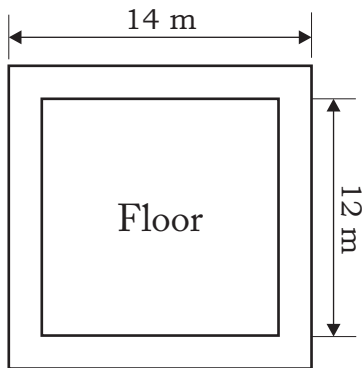
Fig. 4.34: Parallel bar

Specifications

- Bar length: 3.50 m (11.5 ft) ± 1 cm (0.39 in)

- Bar rounded profile: 5 cm (2.0 in) \pm 1 mm (0.039 in) vertical by 4 cm (1.6 in) \pm 1 mm (0.039 in) horizontal.
- Bar width: 4 cm (1.6 in) \pm 1 mm (0.039 in)
- Height of bar from floor: 2 m (6.6 ft) \pm 1 cm (0.39 in)
- Distance between bars: 42 cm (17 in)–52 cm (20 in) (adjustable)

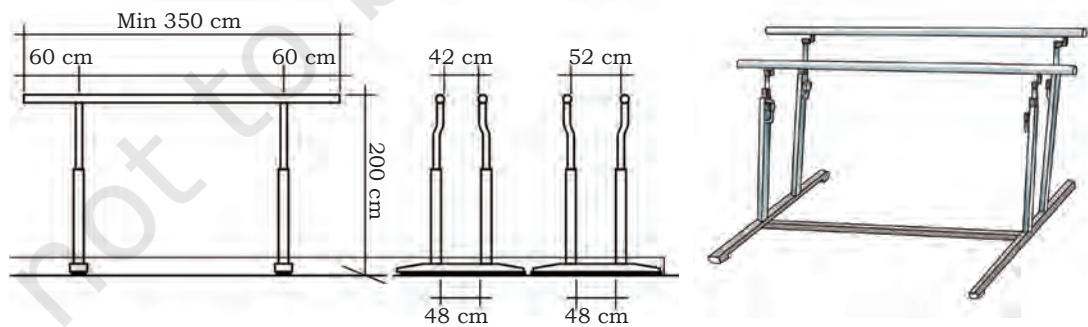
Advanced skills on apparatus

Cartwheel on Balancing Beam

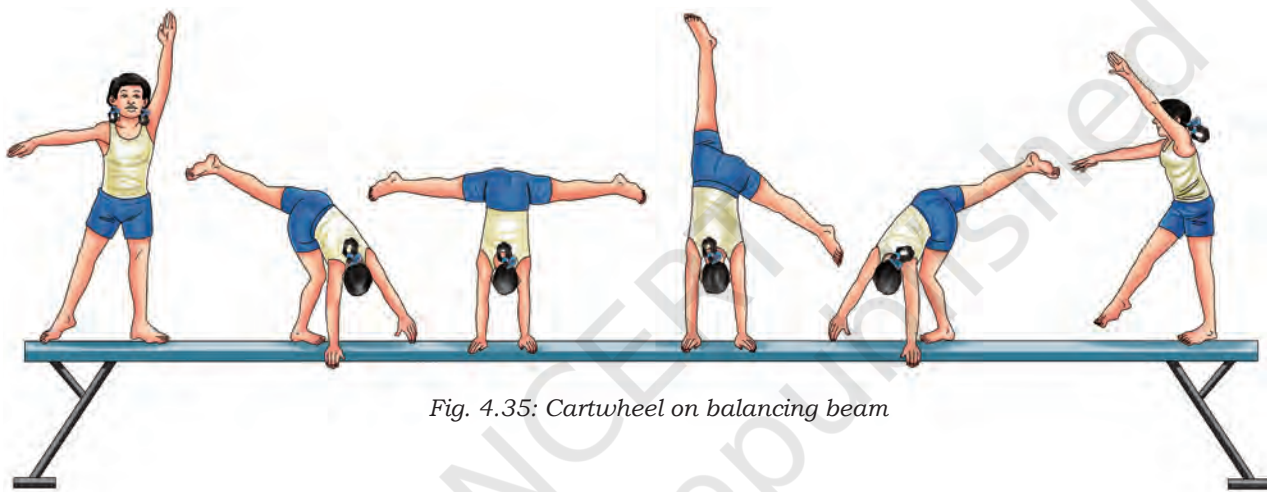
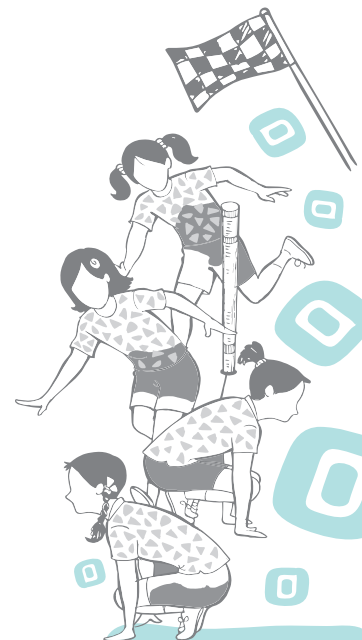

Fig. 4.35: Cartwheel on balancing beam

- Stand erect keeping feet slightly apart.
- With a momentary swing, raise the front leg close to the chest, and arms by the side of the head, step out.
- Place one leg ahead of the rear leg and shift the body weight on the supporting leg.
- Turn shoulder on the side and place alternate arms on the beam at sideways.
- Swing and raise the rear leg first.
- Move the supporting leg to the direction of the cartwheel.
- Turn the trunk up to 130–135 degree angle, keeping legs straddle as much as possible.
- Push off the left arm and place the right leg on the beam surface and vice versa.
- Keep the head in between arms throughout the cartwheel.



Back Handspring or Flic Flac on Balancing Beam

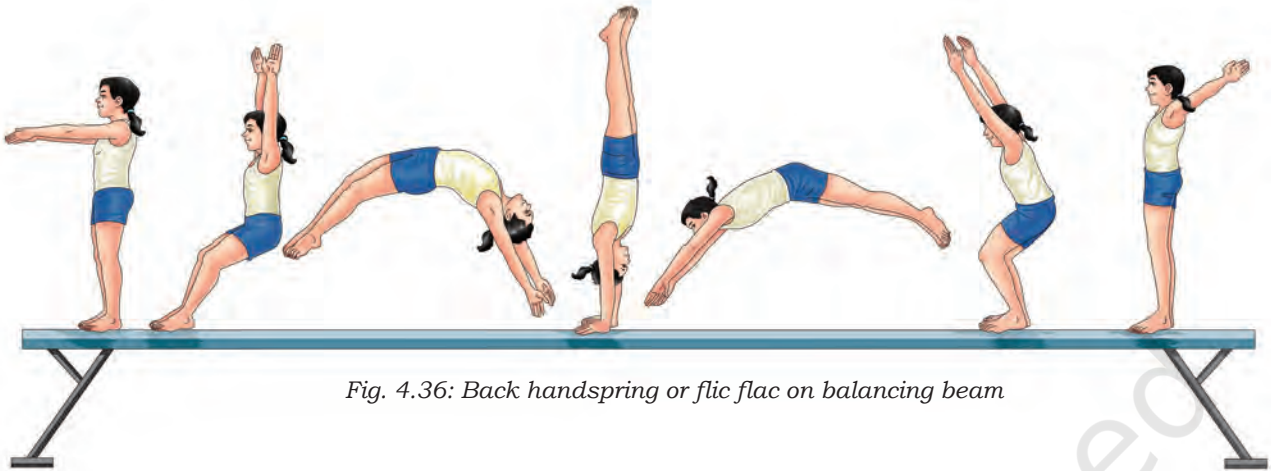

Fig. 4.36: Back handspring or flic flac on balancing beam

- Keep the feet together in balanced position.
- Push off from the toes and take off the body up-backward with swinging arms sharp by the side of the head.
- As the body moves in the air, extend chest as well as pull the upper body from the hip region with the arms inside towards the beam.
- Extend the head and spot the place of contact.
- Place arms slightly on the beam.
- Now, snap down sharply by bending from the hip and simultaneously push off the arms from the beam.
- Land on the beam keeping knees together and hips tight.

KIP Technique on Uneven Bars



Fig. 4.37: KIP on uneven bars

- Stand in front of the low bar.
- Now jump and grasp the bar with over hand grip by extending the arms forward.
- Lead the feet in forward swing and perform a smooth glide under the bar.
- At the end of the glide, extend hips while forcing the shoulders a little forward.
- Now quickly draw the feet on the bar and then extend the hips.
- During the action, press down the bar, raise the legs to the hips, during the rear-ward swing.
- From this support position, execute a strong beat up action.
- Raise the body from the bar, pushing the shoulder over the arm.
- At the end, flexed from the hips, place the sole of both feet on the bar by the side of the grip.
- Circle forward by leading the upper body and shoulders.
- Straighten legs and arms throughout the circle.
- As the circle passes through the line of the bar, raise shoulders and hips, while bending the knees slightly.
- Rotate the grip as body moves down to the upward.

Do You Know?

In Rio Olympics 2016, Dipa Karmakar — ‘The Golden Girl’ became the first Indian girl to qualify for the Gymnastics and was one amongst the five gymnasts who successfully did the Produnova at international level, which is the most difficult vault. Deepa Karmakar won the 4th position in Olympics.

Forward Scissor on Pommel horse

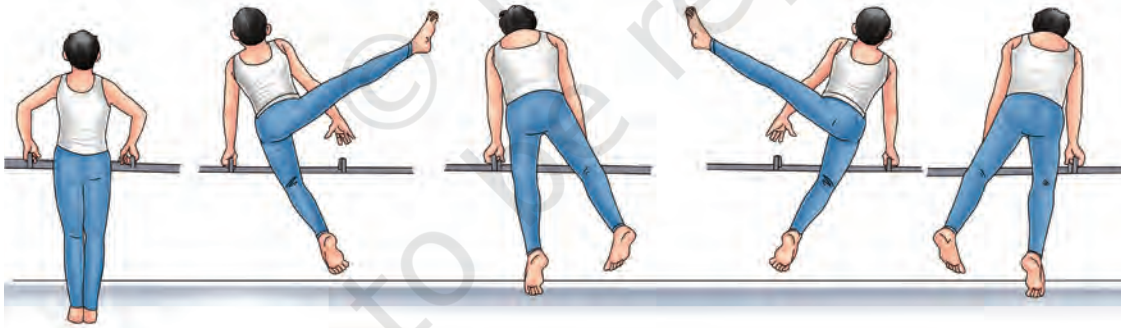
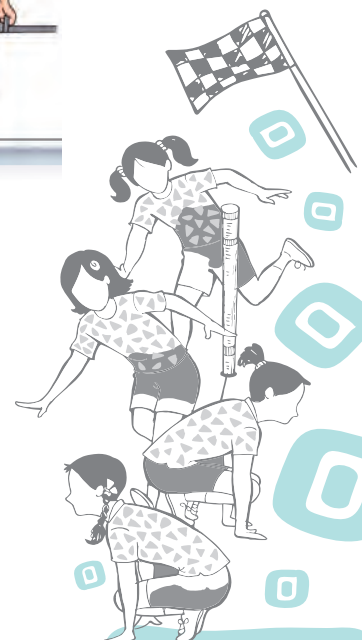

Fig. 4.38: Cartwheel on balancing beam

Pommel horse skill needs coordinated and synchronised movements, with continuous and simultaneous change of hands and legs.

Evaluation Procedure for the above Elements (Movements): There are four elements on the floor exercises and two elements each on all the other apparatuses given in this chapter. The evaluation of these elements will be done based on the following points.



Do You Know?

- The word judo is literally explained by 'Ju' which means gentle and 'Do' that means path. Thus this game is considered as a gentle path of self-defense.
- Judo was first officially taught at the Kōdōkan Judo Institute in Japan in 1882.

- Value of each element =5.00 points (each element will be evaluated out of 5.00 points)
- Value of four elements on floor exercises = 20.00 points (four elements ×5.00 points each =20.00)
- Value of two elements on pommel horse =10.00 (two elements ×5.00 points each =10.00)
- Value of two elements on rings =10.00 points
- Value of two elements on vaulting table =10.00 points
- Value of two elements on parallel bars =10.00 points
- Value of two elements on horizontal bars =10.00 points
- Value of two elements on balancing beam =10.00 points
- Value of two elements on uneven bars =10.00 points

The total value for the boys' section comes to 70.00 points (i.e., 20.00 for floor and 50.00 for rest of the five apparatuses).

The total value for the girls' section comes to 50.00 points (i.e., 20.00 for floor and 30.00 for rest of the three apparatuses).

JUDO**History**

Judo is considered to have originated from Japan. Jigoro Kano invented this game in 1882, and he is considered as the founder father of Judo. It is believed that Judo is the comprehensive form of another ancient self-defence form 'Ju Jutsu'. Judo is an art of self-defence and is considered gentle a way of attack with the help of one's own body. Judo is an ideal form of physical exercise and self-defence. Judo became a system of self-defence in Japan involving throwing, hitting, kicking, choking, bending and pinning an opponent. Jigoro Kano reviewed all the principles of attack and defence and correctly applied these to the game. Judo in male category was introduced in Tokyo Olympic Games in 1964. Judo in women category was added in the Barcelona Olympic, 1992.

Emergence of Judo in India

Judo was introduced through the Judo training centre at Visva Bharati University started by Rabindranath Tagore in 1905. It is believed that on the suggestion of Okakura Kakuzo (master of Judo in Japan), Rabindranath Tagore called a Judo expert from Japan to India in 1905.

Judo Federation of India (JFI) was formed in India in 1965 and thus attained steady growth. Worldwide, Judo is governed



by the IJF (International Judo Federation). The year 1966 witnessed the first National Judo Championship in Hyderabad.

Judo was included in the Asian Games in 1986 at Seoul and India got its much needed break in Seoul Asian Games, where Indians bagged four bronze medals. It was a milestone for team India and since then, India has been performing continuously at international Judo events. Several Indian *Judoka* (a person who practises or is an expert in Judo) qualified for the Olympic Games. Several of them received the prestigious Arjuna Award for their performances. In the 2010 Judo World Cup in Tashkent, Thoudam Kalpana Devi of Manipur became the first Indian to be included among the top-three positions in the World Cup.

Basic Techniques

A few basic techniques of Judo given below with the original terminology and their English version.

1. *Tachi-Waza*—Standing techniques
2. *Koshi-Waza*—Hip techniques
3. *Ashi-Waza*—Leg techniques
4. *Te-Waza*—Hand techniques
5. *Osaе-komi-Waza*—Ground techniques (Holds)
6. *Kensetsu-Waza*—Arm lock techniques
7. *Shime-Waza*—Choking techniques

Basic rules

- (i) During international competitions, each match lasts for four minutes, and points and penalties are awarded by the match referee assisted by the judges.
- (ii) The main objective of the player is to score an 'Ippon' (winning point) before the time runs out. Once a player scores an *Ippon* or is given a 'Hansoku-make' (severe penalty), the match ends immediately. Otherwise, the winner of the match is determined by the scored points.
- (iii) If the points are equal, then the winner is declared on the basis of the least number of penalty points known as 'Shido', means minor penalties.
- (iv) *Judoka* are not allowed to employ any of the outlawed techniques, attacking joints other than the elbows, punching or kicking, touching the opponent's face, or intentionally injuring the opponent in any way.
- (v) In a judo bout, *Judoka* can achieve two types of scores (*Ippon* and *waza-ari*).

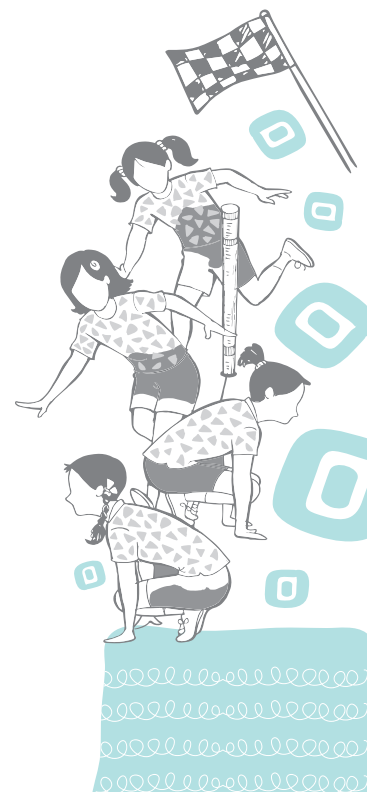











Do You Know?

- Yasuhiro Yamashita is a legend of world Judo.
- Judogi is the formal Japanese name for the traditional uniform used for Judo practice and competition.

- (vi) *Ippon* is the best, as it results in immediate victory. *Ippon* can be achieved by throwing an opponent in such a way as to make them land on their back.
- (vii) *Ippon* can also be achieved by trapping an opponent in an armhold or stranglehold to the extent that it forces the opponent to surrender or immobilising an opponent on the floor for at least 20 seconds.
- (viii) The next best score is *waza-ari*, which is awarded for lesser throws than those required for scoring *ippon*, and for immobilising the opponent for less than the time required to score *ippon*, i.e., 10 seconds.
- (ix) There are two types of penalties awarded in judo—*shido* and *hansoku-make*. Awarding *hansoku-make* to a judoka automatically gives the match to the opponent. *Hansoku-make* is given for major rule breaches or for the accumulation of three *shidos*. The third *shido* becomes *hansoku-make* (disqualified).

Specifications of Dress and Belts**Table 9: Judogi (Judo Dress) and Obi (Belt)**

(Blue and White)		
Rank	Senior	Junior
Sixth <i>kyu</i> (beginner)	 Light Blue	 Light Blue
Fifth <i>kyu</i> Fourth <i>kyu</i>	 White	 White
Third <i>kyu</i> Second <i>kyu</i> First <i>kyu</i>	 Brown	 Purple

First <i>dan</i> Second <i>dan</i> Third <i>dan</i> Fourth <i>dan</i> Fifth <i>dan</i>	 Black
Sixth <i>dan</i> Seventh <i>dan</i> Eighth <i>dan</i>	 Red and White or  Black
Ninth <i>dan</i> Tenth <i>dan</i> Eleventh <i>dan</i>	 Red or Black 

Golden Score

In case there is no score(s) or scores are equal, the contest will continue till golden score. Any score or penalties from regular time will remain on the scoreboard and will be extended into the golden score overtime period. The decision in the golden score is made by the deference or score or hansoku-make.

Measurements of Contest Area in Judo

A traditional Judo match takes place on *tatami* mats measuring 14×14 meters or 16×16 meters, with a combat area of 9×9 meters or 10×10 meters marked out within it. Players must wear the designated uniform with an appropriate knotted belt. The Judo player/athletes who are called Judoka, must bow before stepping onto the mat, and must bow to each other before and after the competition.

Competition area

The competition area is a minimum of 14m×14m and is divided into two zones. The inner zone called the contest area is a minimum of 8m×8m to a maximum of 10m×10m. The outer zone is the safety area and is a minimum of 3m wide. The contesting area is of different colour to the safety area.

When using two or more adjoining competition areas, the common or shared safety area is 4m. A free zone, a minimum of 50 cm, must be maintained around the entire competition area.

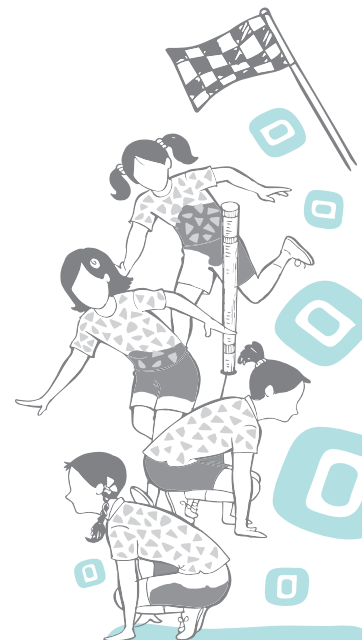

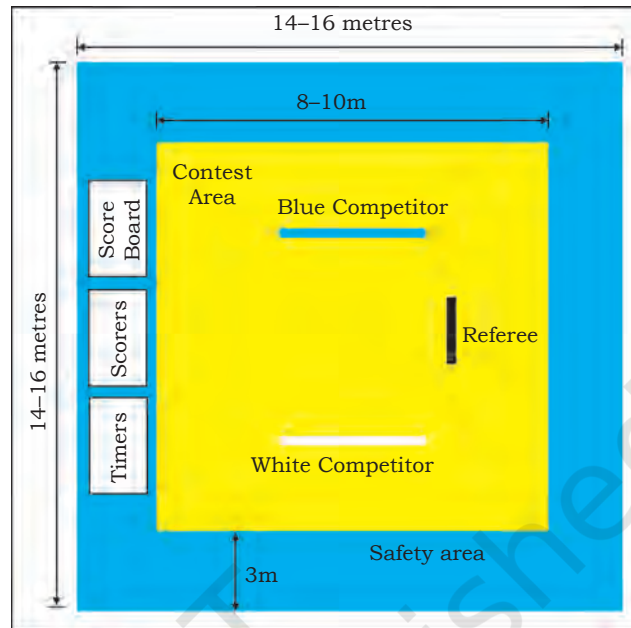

Fig. 4.39: Competition area of judo

Tatamis

The competition area is covered by a *tatamis* or similar material. The *tatamis* is made of pressed foam and is 1m×2m or 1m×1m.

Platform

The platform is optional and is made up of solid wood. It measures approximately 18m×18m. When using a platform, it is recommended that the safety area is a minimum of 4m wide around the competition area.

Judogi (Uniforms)

Judoka must wear the appropriate *Gi* (uniform). *Judogi* is no more than 5 cm above the ankle and wrist and is tied with the correct style of knotted belt.

Referees and Judges

Contest occurs under the supervision of a referee and two judges. The referee stands inside the contest area, and the two judges sit at the outer corner of the contest area, diagonal to each corner.

Contestants

The name of the blue uniform contestant is called first, followed by the name of the white uniform contestant.



The contest begins with the blue contestant stands on the right side of the referee while the white contestant stands on the left. The referee starts the bouts by saying Hajime (start). The referee stops the bouts temporarily by saying Mate.

Commonly used terms in Judo

1. *Hajime*—Start
2. *Sore-mate*—time up
3. *Mate*—temporarily stop a contest
4. *Osae-komi*—pinned the opponent
5. *Toketa*—if the pinned opponent successfully breaks the pin (breaking the hold)
6. *Kuzushi*—breaking the balance of the opponent

Important Tournaments

1. National School Games
2. CBSE School National Competition
3. Federation Cup
4. International Competitions like, Asian Games, Commonwealth Games, and Olympics.

Judo weight categories

The following weight categories are classified for the purpose of competition.

Table 10: Judo Weight Categories List

U-19 Boys	U-19 Girls
Below 40 kg	Below 36 kg
Below 45 kg	Below 40 kg
Below 50 kg	Below 44 kg
Below 55 kg	Below 48 kg
Below 60 kg	Below 52 kg
Below 66 kg	Below 57 kg
Below 73 kg	Below 63 kg
Below 81 kg	Below 70 kg
Below 90 kg	Below 70 kg
Below 90 kg	---

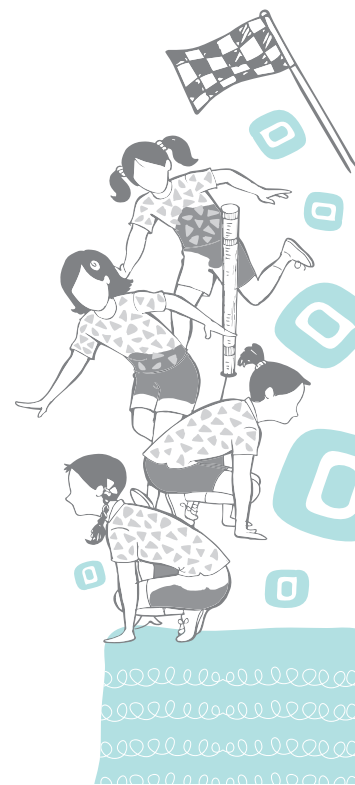

Do You Know?

In the 1912 Olympic games, Fanny Durack of Australia became the first Female Olympic Swimming Gold Medalist in 100 m Free Style.

SWIMMING**History**

In the early 1800s, swimming emerged as a competitive sport in England. The first indoor swimming pool, St George's Baths, was opened for public use in the year 1828. The first national governing body, the Amateur Swimming Association, was formed in the year 1880.

The Olympic Games were held in 1896 in Athens, which was a male-only competition. Six events were planned for the swimming competition, but only four events were actually contested—100 m, 500 m, and 1200 m freestyle and 100 m for sailors. The first gold medal was won by Alfréd Hajós of Hungary in the 100 m freestyle.

In 1908, the world swimming body 'Federation Internationale de Natation' (FINA) was formed.

Women were first allowed to take part in swimming competitions in the 1912 Summer Olympics in Stockholm competing in freestyle races. In the 1912 games, Harry Hebner of the United States won the 100 m backstroke.

History of Swimming in India

In the year 1948, the Swimming Federation of India (SFI) was formed. Since then this body is looking after the promotion and administration of aquatic sports in India. The SFI is affiliated to FINA, the world governing body for the sport.

Few not able Indian swimmers are Sachin Nag, Sufyan Shaikh, Khajan Singh, Nisha Milled, Sikha Tandon, and Sandeep Sejwal.

Table 11: Dimensions of Swimming Pool

Physical Property	Specified Value
Length	50 m
Width	25 m
Depth	2.0 m (6 ft 7 in) minimum, 3.0m (9 ft 10 in)
Number of lanes	10
Lane width	2.5 m (8 ft 2 in)
Water temperature	25 – 28°C (77–82°F)



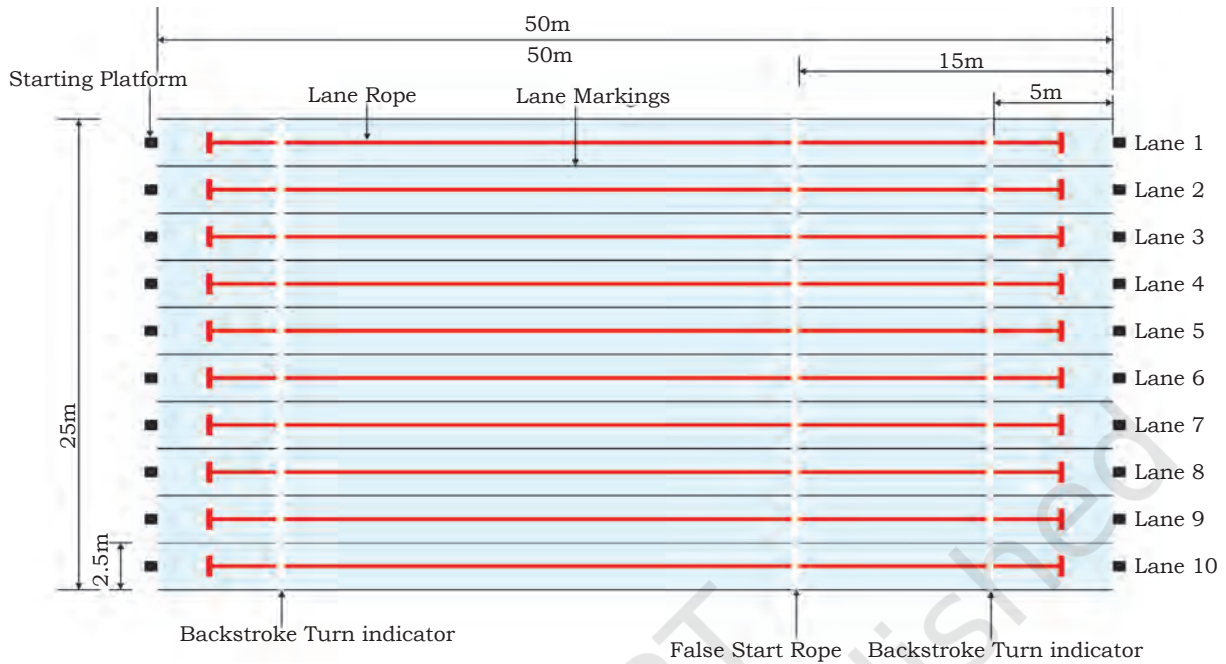

Fig. 4.40: Aerial view of swimming pool

Starting Platforms

Starting platforms shall be firm and give no springing effect. The height of the platform above the water surface shall be from 0.5 metre to 0.75 metre. The surface area shall be at least 0.5 metre×0.5 metre and covered with a non-slip material. Maximum slope shall not be more than 10 degrees.

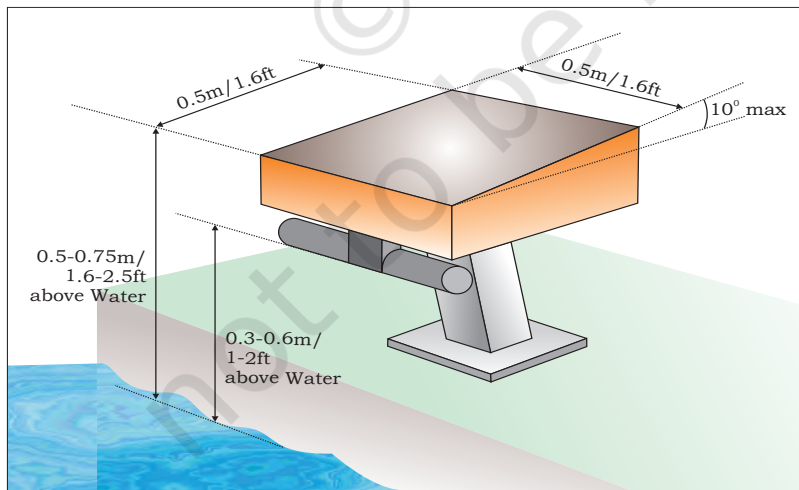
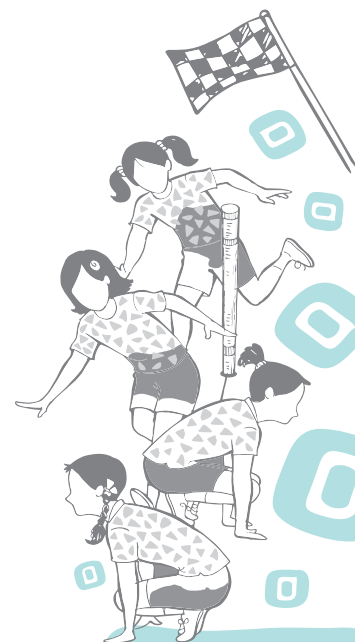

Fig. 4.41: Starting platforms

Teaching swimming in early stages

Teaching swimming sounds like a task for those who know how to swim. But if you are not careful, you can scare people



Activity 4.9

Make a list of the Olympic events of swimming.

away from the water for a good amount of years. So, how you teach swimming is very important. If swimming is not taught properly and correctly, children can develop a phobia.

Role of the Teacher

1. Cheerful attitude
2. Understand individual differences
3. Offer plenty of encouragement
4. Recognise the fear of the student
5. Develop self-confidence in students
6. Praise students
7. Have patience

The beginning

Assemble the class at pool side at a given point of time. First, orient the children with pool surroundings and swimming environment by taking them around the pool, showing various equipment, changing rooms, different depths of the pool, specially the limits of shallow water. Also brief the safety, health and hygiene rules which are to be followed by all at the pool. Engage them in talks and bring them closer to the pool. Make them sit on the deck around the shallow end with feet hanging and swinging in the water, making waves. Also encourage them to lean forward and touch the water with hands.

Entry into the pool

Organise a partner system (spotter system), one acting as a spotter for the other. If required, air tubes and arm bands may be used. Various methods of safe entry may be used, i.e., walking down the steps if provided at the shallow end facing the pool side, sit on the pool side, grip the railing with the other hand, try the same method by facing pool side and jump towards the teacher/partner already into the water to support.

Movement at the shallow end

Encourage the children to move along the wall, rail or scum gutter immediately on entering the water. Take support with one hand and paddle with the support of rail or wall and paddle with both hands while walking at the shallow end. Later, introduce hopping and let them sink down up to shoulder level.

Breathing with the mouth may be introduced by blowing into the water taken in both hands or by putting the face on the surface in standing position with feet apart.



Getting the feet off the bottom

Walking across the pool with shoulders submerged and arms at stretch for support and holding kick boards with both hands. Gradually increase the speed and lean forward until the feet rise from the bottom. Students stand back towards the wall in forward leaning position, approximately 2 meters away, arms stretched forward on the surface and shoulder submerged. From this position, they lean forward on the water, push off with the feet and glide towards a wall, rail or scum gutter.

Floating

Remember that it is much easier to float on the surface by keeping the body relaxed than by thrashing about with arms and legs. After having left the bottom with support, the child should now be ready to float without any support or help.

Types of Floats

There are many techniques of floating, such as—

1. Tuck float
2. Jellyfish float
3. Prone float
4. Star float
5. Supine float

Pushing off, gliding and standing up again

The beginners should now gain confidence, as swimming is based on the principle of gliding across the surface of the water. Stand with your back to the side walls of the pool and close up against it, leave the shoulders into the water keeping the head above the surface, now place the foot against the wall, take a deep breath, lower the face into the water and kick the wall with the raised foot.

Lift the other leg so that both the legs end up straight and pointed behind. The body will stretch on the surface and now glide towards the partner who is standing 4–5 meters away. The partner now holds the out stretched hand, lowers the hips, pulls the knees under the body, thrust them down to the bottom placing a little apart, and the beginner stands up on the floor raising the head and shoulders.

Practice gliding further with a float held in extended hands. It enables the beginner to stay on the surface and make him ready to learn the stroke.

Which Stroke First?

There are no set rules regarding the order in which swimming strokes should be taught to the beginners. There are various

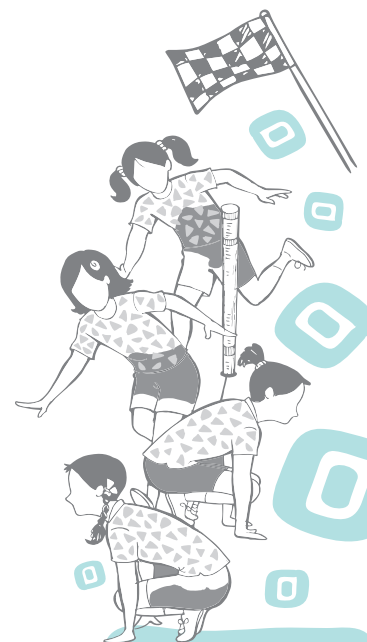

schools of thought about the stroke best suited to the beginners. Some suggest back stroke for beginners.

Whatever the merits of any stroke may be, a multiple stroke approach in the early stages may be preferred whereby the learner is given an experience of all the strokes and later the learner allowed to make up one's own mind. The butterfly stroke, however, may be introduced at a later stage as it requires a high degree of swimming proficiency, strength and co-ordination.

Fundamental rules and regulations

Following rules should be followed by the competitors while swimming in a race.

- (i) A swimmer shall swim the course alone and cover the whole distance to qualify.
- (ii) A swimmer must finish the race in the same lane in which he started.
- (iii) In all the events, a swimmer while turning, shall make physical contact with the end of the pool. The turn must be made from the wall, and it is not permissible to take a stride or step from the bottom of the pool.
- (iv) Standing on the bottom during freestyle events or during the freestyle portion of medley events shall not disqualify a swimmer, but he shall not walk.
- (v) Pulling on the lane rope is not allowed.
- (vi) Obstructing another swimmer by swimming across another lane or interfering the other shall disqualify the offender. Should the foul be intentional, the referee shall report the matter to the member promoting the race and to the swimmer so offending.
- (vii) No swimmer shall be permitted to use or wear any device that may aid speed, buoyancy or endurance during a competition (webbed gloves, fins, etc.). Goggles may be worn.
- (viii) Any swimmer not participating in a race shall be disqualified, if they enter the water, in which an event is being conducted before the preceding team-mate touches the wall.
- (ix) There shall be four swimmers in each relay team.
- (x) In relay events, the team of swimmers whose feet lose touch with the starting platform before the preceding team-mate touches the wall, shall be disqualified.
- (xi) Any relay team shall be disqualified from a race if a team member, other than the swimmer supposed to



swim that length, enters the water when the race is being conducted, before swimmers of all the teams have finished the race being conducted.

- (xii) The member of a relay team and their order of competing must be nominated before the race. Any relay team member may compete in the race only once.

The composition of a relay team may be changed between the heats and finals of the event, provided that it is made up from the list of swimmers properly entered by a member of that event. Failure to swim in the order listed, will result in disqualification. Substitutions may be made only in the case of a documented medical emergency.

- (xiii) Any swimmer having finished his race, or his distance in a relay event, must leave the pool as soon as possible without obstructing any other swimmer who has not yet finished his race. Otherwise the swimmer committing the fault or his relay team shall be disqualified.
- (xiv) Should a foul endanger the chances of success of a swimmer, the referees shall have the power to allow him to compete in the next heat or, should the foul occur in a final event or in the last heat, he/she may order it to re-swim.
- (xv) No pace-making shall be permitted, nor may any device be used which has that effect.

Swimwear

The swimwear includes swimsuit, cap and goggles, which shall be in good moral state and suitable for the individual sports disciplines and should not carry any symbol which may be considered offensive. The swimsuits shall be non-transparent. It is permissible to wear two caps.

Table 12: Events Conducted in the World Championships in 50 m pool

Events	Men	Women
Freestyle	50m, 100m, 200m, 400m, 800m, 1500m	50m, 100m, 200m, 400m, 800m, 1500m
Backstroke	50m, 100m, 200m	50m, 100m, 200m
Butterfly	50m, 100m, 200m	50m, 100m, 200m
Ind. Medley	200m, 400m	200m, 400m
Relays Freestyle	4×100m, 4×200m	4×100m, 4×200m

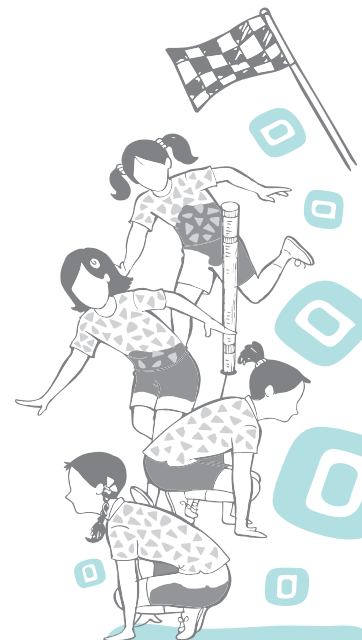

Medley	4×100m	4×100m
Mixed Relays	4×100 Freestyle and 4×100m Medley	

Fundamental Techniques

Techniques in swimming are classified into three main categories—

1. Strokes
2. Starts
3. Turn

Strokes

In swimming, there are four strokes used in the competition all over the world.

1. Front Crawl or Freestyle
2. Back Crawl
3. Breast
4. Butterfly

Teaching stages of front crawl stroke

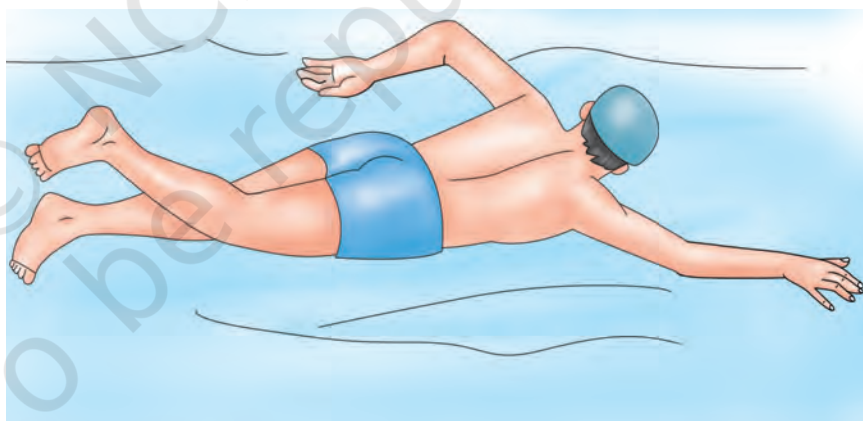

Fig. 4.42: Front crawl stroke

1. **Body Position:** The basic body position for teaching the front crawl stroke is streamlined prone position. The swimmer lies flat on his stomach with both arms stretched out in front, passing by the side of ears and the water level is at hair line. Both legs are extended to the back with toes pointed.
2. **Arm Action:** The arms are pulled alternately from front to back inside the above. While one arm is pulling/pushing, the other arm is recovering. The

arm strokes provide most of the forward propulsion. The arm action is further divided into entry, catch, pull, push, release, initial and final recovery.

3. **Leg Action:** The leg movements in front crawl is called the flutter kick. The legs move alternatively up and down. The leg movement originates from the hip joint. While one leg kicks downward, the other leg recovers upward. The knees are flexed with toes pointed during the downbeat and are kept straight with toes relaxed during the upbeat. Though, the leg action provides only a small amount of forward propulsion when combined with arm action, but it is essential to attain horizontal body position and reduce the body drag.
4. **Lateral Breathing:** Breathing in the front crawl stroke is done on the side, whichever side is convenient to the swimmer. The swimmer takes the breath through the mouth by turning the head to the side of the pushing arm, at the beginning of recovery. Soon the face goes back into the water and the swimmer breathes out more through the mouth and only a small portion through the nose. The mouth goes to the other side also while breathing out but does not come out of the water. The swimmer continues exhalation and goes back to the same side to inhale again. Usually the swimmers take breath every arm cycle.
5. **Body Roll:** The body of the front crawl stroke swimmer rotates around its long axis with every arm stroke so that the shoulder of the recovering arm is higher than the shoulder of the pulling/pushing arm. This helps the pulling arm to sink down and perform a deeper pull, and on the other hand, it facilitates a high elbow of the other arm.

Teaching stages of back crawl stroke

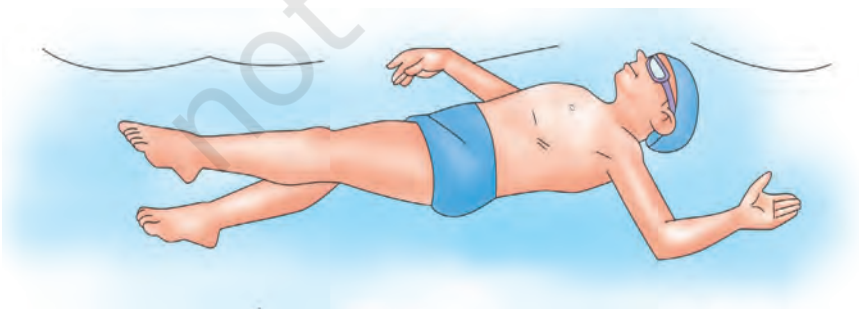
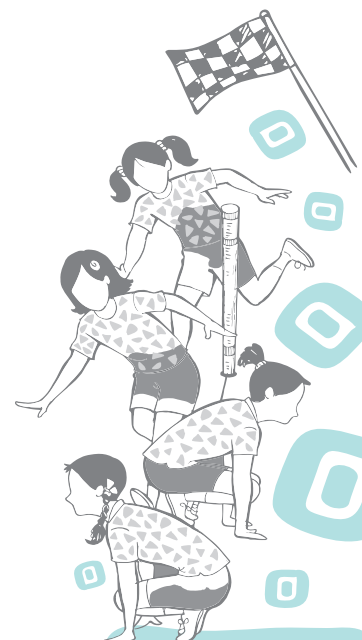

Fig. 4.43: Back crawl stroke



1. **Body Position:** The basic body position for teaching the back crawl stroke is streamlined supine position. The swimmer lies flat on his back with both arms stretched back over head, passing by the side of ears. Face is out of the water and both legs are extended back with toes pointed. Hips are just below the water surface.
2. **Arm Action:** The arms are pulled alternately from back to front inside the water and recovers above the water with straight arm over the body. While one arm is pulling/pushing, the other arm is recovering. The arm strokes provide most of the forward propulsion. The arm action is further divided into various parts, such as, the entry, catch, pull, push, release, and recovery.
3. **Leg Action:** The legs move alternately up and down. The leg movement originates from the hip joint. While one leg kicks downward, the other leg recovers upward. The knees are flexed with toes pointed during the upbeat and are kept straight with toes relaxed during the downbeat.
4. **Lateral Breathing:** Breathing in backstroke is very easy, as the mouth and nose are usually above the water. The swimmer breathes once in every arm cycle.

Teaching stages of breast stroke

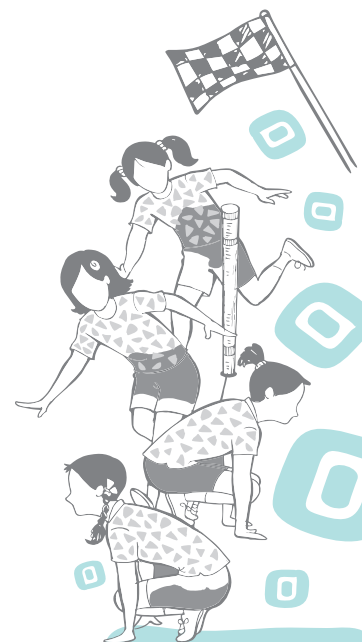

Fig. 4.44: Breast stroke

1. Practise the kick and its movements on dry land of the water.
2. Practise the kick on the edge of the swimming pool in the water.
3. Kick back with a board held to the chest in prone position. Try to keep the knees stable at the surface and draw both the feet to the buttocks by bending at the

knee, not at the hip. Allow the swimmer to let their feet work in a wide arc, if necessary, as the main aim is to get their feet turned out. Once the swimmer has their feet ready to kick back, it is advisable to get them to pause at this point and consciously turn their feet out before kicking back, and pause again while the legs are fully extended.

4. Kick on front, holding the board on the back and with thumbs underneath and arms fully extended. Place the face in water and proceed to do three kicks and then breathe. Stretch and glide after each kick. Keep the head very stable with the eyes looking to the front at all times. Rocking movements of the head are best avoided as they affect the body position and the swimmer can lose track of where their arms and legs are. A stable head helps maintain a reference point. The breathing is performed by raising and lowering the head as one unit.
5. Repeat Step 4 by doing two kicks and one round of breathing.
6. One breath and one kick. Holding the board (as above) with eyes looking directly ahead and arms and legs fully extended. Ask the swimmer to lift their head and shoulders (by contracting their back muscles), then lift their feet, lower their head and shoulder, then kick and glide. Repeat this sequence over and over—stressing to the swimmer that the first movement in the sequence is raising of the head and shoulders.
 - a. **The Pull:** Swimmers have a lot of difficulty with learning the pull because they achieve very little propulsion. This causes difficulty in teaching the stroke as the swimmers modify the pull incorrectly, in order to gain propulsion. To avoid this temptation, the use of fins is employed to enable them to propel themselves while they develop the correct stroke mechanics. As the swimmers become more proficient, the fins are removed.
 - b. **The Complete Stroke:** By following the above progression, the swimmer has learned to kick and breathe, and pull and breathe with the correct timing. All that remains to do now is, to connect the two skills together and the timing should look after itself – as it has already been taught.



- (i) Three kicks with arms extended and one pull. Breathe only on the full stroke. Glide after each kick and look straight ahead at all times.
- (ii) Two kicks with arms extended and one pull. Breathe only on the full stroke. Glide after each kick.
- (iii) Normal breast stroke with a long glide—beginning the next stroke after exhalation has been completed. The above three skills are important for consolidating the stroke. Try to develop power in the pull and the kick whilst still holding a glide in the stroke. By doing this, you will develop speed and strength without running the risk of losing the timing. Only when the swimmer is swimming strongly and correctly, should the glide be reduced for faster swimming. Fast breast stroke swimming is achieved with minimum glide but with the maintenance of maximum arm and leg extension. Teaching breast stroke is an exercise of patience but if you follow the process outlined above, you will find it as an effective way for teaching breast stroke with good technique from the earliest stages.

Teaching stages of butterfly stroke



Fig. 4.45: Butterfly stroke

1. **Body Position:** The body must be horizontal and streamlined. The teacher/coach must make sure that the swimmer can push off the wall in a streamlined position initially on the surface and progress to dropping down under the water and pushing off under water while maintaining a streamlined body position. This takes time and must be worked on continually. Apart from teaching the swimmer the position needed for their body, it also

develops the leg muscles needed for the push off in their turns and eventually the leg drive needed for their dives.

Body should be either in the prone position. Legs together, toes pointed, arms extended in front of the shoulders, head positioned between the arms, ears squashed between the arms, and one hand on top of the other. There should be no gap between the arms and the ears. The top hand must be locked over the bottom hand with, no gaps.

2. Dolphin Kick: The swimmers lie on the tummy, in a streamlined position and push the chest down into the water and let their bottoms rise and then vice versa, i.e., chest up and bottoms down. They can do this with the hands by the side, to begin. They continue the movement, trying to get to the other side of the pool. They must do 3–4 movements without breathing and push the chin forwards to grab a quick breath and then the head returns to the streamlined position with the eyes looking towards the bottom. Once this has been established, try to extend the arms in front of the head in the streamlined position and perform the same movement while breathing at every fourth kick. Slowly build up the strength in the kick by doing short distances with short to moderate rest intervals. The goal is for a quick movement from the legs and this takes strength and practice. Goal should be to execute three kicks per second. All kicking practices can be done with and without fins.

Starts

All four competitive strokes are to be started in the competition by using a pair of techniques known as the start. The swimmer emphasises on the quickest technique which allows him a stinger push off from the starting position. The popular starting techniques are—

1. Grab start
2. Circular start
3. Racing start
4. Conventional start
5. Track start

Teaching Stages of Start

For teaching the 'start' to the beginners, the following sequence is followed—

1. Position on the block
2. Take off

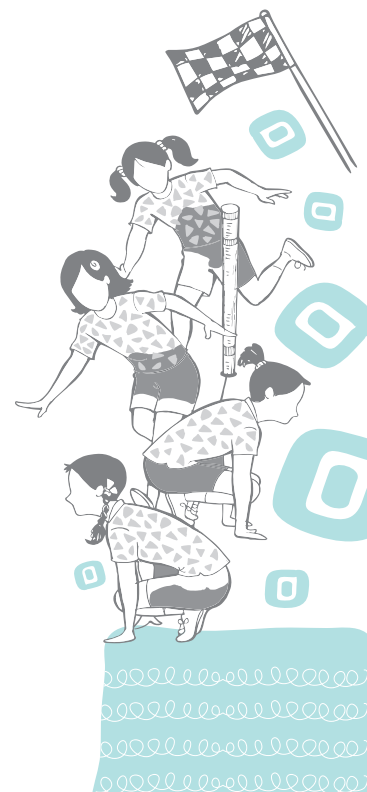

3. Flight (position in the air)
4. Entry into the water (glide first stroke)

However, back stroke uses almost a uniform technique, which does not have any special name and is known as backstroke start.

Turns

During the race, the swimmer must take a turn from the end of the wall to complete the full distance of the race. The swimmers try to use such techniques which are quicker and gives strong push off from the wall within the permissible rules of the stroke. The various turns used by the swimmers are:

1. Simple
2. Throw away
3. Summersault
4. Flip
5. Roll over
6. Breast stroke
7. Butterfly

Teaching Stages of Turn

1. Approach to the wall
2. Turn or touch
3. Push off
4. Glide First

TABLE TENNIS

History

Table tennis, also known as 'Ping-Pong', is a popular indoor recreational sport in India. The International Table Tennis Federation (ITTF) was founded in 1926. Table tennis made its Olympic debut at the 1988 Seoul Games. At present, there are 226 member nations affiliated to International Table Tennis Federation. Table Tennis Federation of India is one of the founder members of ITTF and officially started playing table tennis with the establishment of Table Tennis Federation of India (TTFI) in 1926. Table tennis has been contested at the Asian Games since 1958. Table tennis competition has been in the Commonwealth Games as an optional sport since 2002. World Team Table Tennis Championships, which include men's team and women's team events, started in the year 2000. World Table Tennis Championships have been held since



1926, and biennially since 1957. Earlier the game was played up to 21 points, which was changed to 11 points effective from September 2001. The change of rule made the game faster. The ITTF also changed the rule of five services by one player at a time to two services effective from 2002. All the table tennis events since 2014 are now being played with a new poly material ball.

Facilities and Equipment Required

Table tennis is an indoor game requiring a racket, net, net posts, a table and a ball.

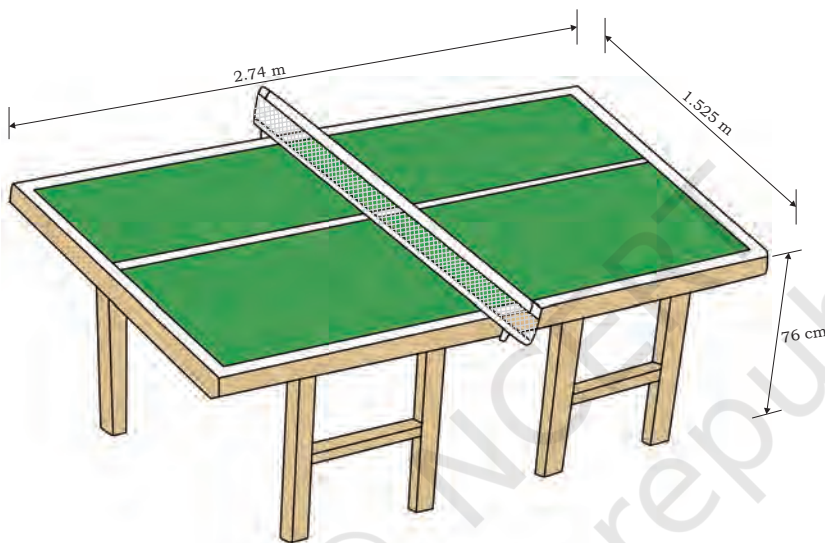
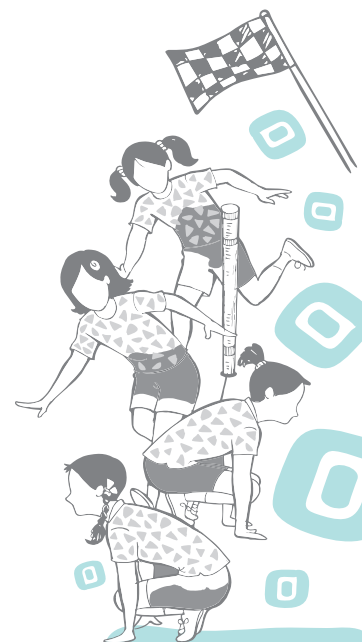

Fig. 4.46: Table of table tennis

- Surface of the table shall be rectangular, 2.74 m long and 1.525 m wide, and shall lie in a horizontal plane 76 cm above the floor.
- The playing surface may be of any material and shall yield a uniform bounce of about 23 cm when a standard ball is dropped on to it from a height of 30 cm.
- The playing surface shall be uniformly dark coloured and matt, but with a white side-line, 2 cm wide, along each 2.74 m edge and a white end line, 2 cm wide, along each 1.525 m edge.
- For doubles, each court shall be divided into two equal half-courts by a white centre line, 3 mm wide, running parallel with the side lines; the centre line shall be regarded as a part of each right half-court.
- The net shall be suspended by a cord attached at each end to an upright post 15.25 cm high, the outside limits of the post being 15.25 cm outside the side line.

Do You Know?

Sharath Kamal is a famous Table Tennis player of India, who was conferred Padma Shri by the Government of India.



Do You Know?

Manav Thakkar of India secured top position in the junior world ranking of International Table Tennis Federation during the first month of 2018.

Activity 4.10

Check the Table Tennis tables of your school by bouncing a Table Tennis ball as per the rules.

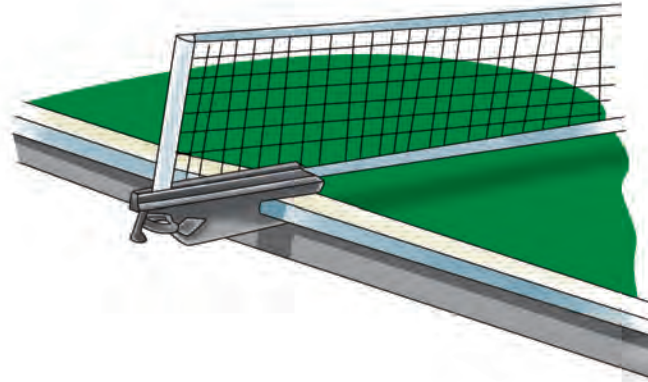

Fig. 4.47: Net used in table tennis

- The top of the net, along its whole length, shall be 15.25 cm above the playing surface.

Ball

- The ball shall be spherical, with a diameter of 40 mm and weigh 2.7 g.
- It shall be made of celluloid or similar plastics material and shall be white or orange in colour.



Fig. 4.48:
Table tennis ball

Racket

- Racket may be of any size, shape or weight, but the blade shall be flat and rigid.
- At least 85 per cent of the blade by thickness shall be of natural wood; an adhesive layer within the blade may be reinforced with the fibrous material, but shall not be thicker than 7.5 per cent of the total thickness or 0.35 mm, whichever is the smaller.
- A side of the blade used for striking the ball shall be covered with either ordinary pimples rubber, with pimples outwards having a total thickness including adhesive, of not more than 2.0 mm, or sandwich rubber, with pimples inwards or outwards, having a total thickness including adhesive of not more than 4.0 mm.

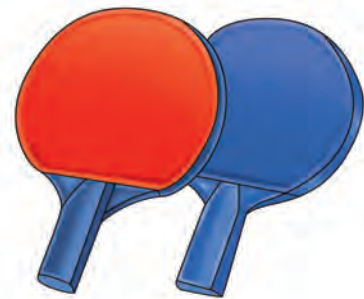

Fig. 4.49: Table tennis racket



Playing conditions

The playing space shall be rectangular and not less than 14 meter long, 7 meter wide and 5 meter high. The four corners may be covered by surrounds of not more than 1.5 meter length. For para event, F.O.P. (Field of Play) shall not be less than 8×6 meter. In an international event, the light intensity equally measured at the height of the playing surface shall be at least 1000 lux uniformly over the whole playing area.

Definitions

- A rally is the period during which the ball is in play.
- The ball is in play from the last moment at which it is stationary on the palm of the free hand before being intentionally projected in service until the rally is decided as a let or a point.
- A let is a rally of which the result is not scored.
- A point is a rally of which the result is scored.
- The racket hand is the hand carrying the racket.
- The free hand is the hand not carrying the racket; the free arm is the arm of the free hand.
- A player strikes the ball if he or she touches it in play with his or her racket, held in the hand, or with his or her racket hand below the wrist.
- A player obstructs the ball if he or she, or anything he or she wears or carries, touches it in play when it is above or travelling towards the playing surface, not having touched his or her court since last being struck by his or her opponent.
- The server is the player due to strike the ball first in a rally.
- The receiver is the player due to strike the ball second in a rally.
- The umpire is the person appointed to control a match.
- The assistant umpire is the person appointed to assist the umpire with certain decisions.
- Anything that a player wears or carries includes anything that he or she was wearing or carrying, other than the ball, at the start of the rally.
- The end line shall be regarded as extending indefinitely in both the directions.

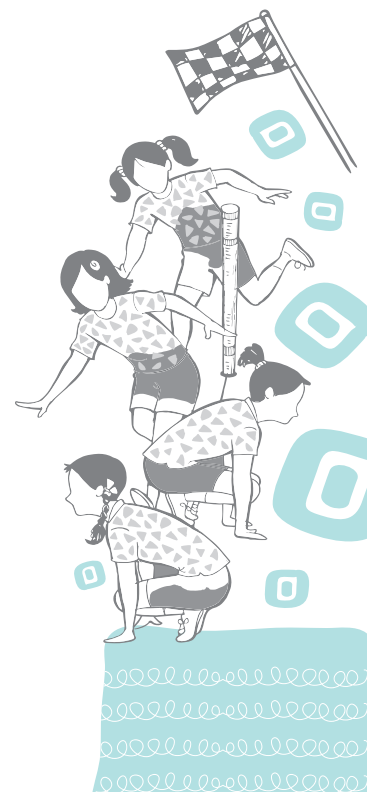

Do You Know?

India has won a total of five medals in the 19th Commonwealth Games.

Functional Rules of Table Tennis

- The right to choose the initial order of serving, receiving and starting at a particular end shall be decided by toss and the winner may choose to serve or to receive first or to start at a particular end.
- When one player or pair has chosen to serve or to receive first or to start at a particular end, the other player or pair shall have the other choice.
- After 2 points have been scored, the serving player or pair shall become the receiving player or pair. This will continue until the end of the game, unless both the players and pairs score 10 points or the expedite system is in operation, when the sequence of serving and receiving shall be the same but each player shall serve for only 1 point in turn.

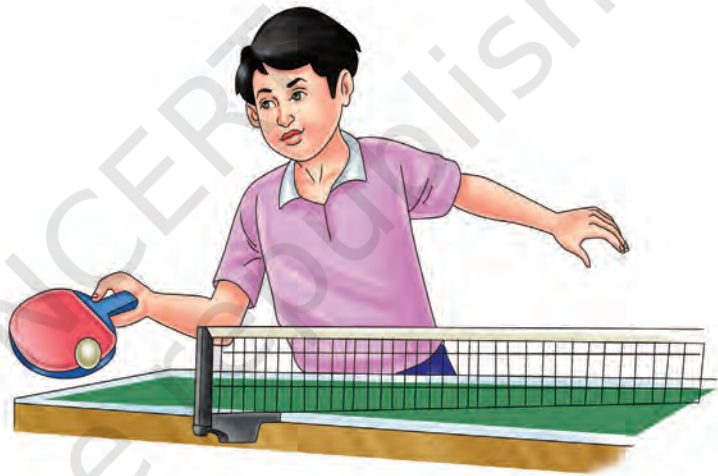

Fig. 4.50: Player playing table tennis

- In each game of a doubles match, the pair having the right to serve first shall choose which of them will do so and in the first game of a match, the receiving pair shall decide which of them will receive first; in subsequent games in the match, the first server having been chosen, the first receiver shall be the player who served to him or her in the preceding game.
- In doubles, during the change of service, the previous receiver shall become the server and partner of the previous server shall become the receiver.
- The player or pair serving first in a game shall receive first in the next game of the match and in the last possible game of a doubles match, the pair due to receive next shall change their order of receiving when the first pair scores 5 points.



Fig. 4.51: Left arm service in table tennis

- The player or pair starting at one end in a game shall start at the other end in the next game of the match and in the last possible game of a match, the players or pair shall change ends when the first one player or pair scores 5 points.
- If a player serves or receives out of turn, play shall be interrupted by the umpire as soon as the error is discovered and shall resume with those players serving and receiving who should be server and receiver respectively at the score that has been reached, according to the sequence established at the beginning of the match and, in doubles, to the order of serving chosen by the pair having the right to serve first in the game during which the error is discovered.
- If the players have not changed ends when they should have done so, play shall be interrupted by the umpire as soon as the error is discovered and shall resume with the players at the ends at which they should be at the score that has been reached, according to the sequence established at the beginning of the match.
- In any circumstances, all points scored before the discovery of an error shall be reckoned.
- The expedite system shall come into operation after 10 minutes' play in a game or at any time when requested by both the players or pairs except that expedite system shall not be introduced in a game if at least 18 points have been scored.
- If the ball is in play when the time limit is reached and the expedite system is due to come into operation, play shall be interrupted by the umpire and shall resume

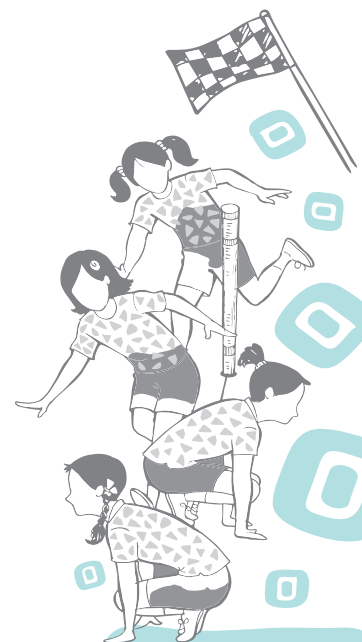

Activity 4.11

Play doubles and mixed doubles in Table Tennis with your classmates by following the laws of the game.

with service by the player who served in the rally that was interrupted; if the ball is not in play when the expedite system comes into operation, play shall resume with service by the player who received in the immediately preceding rally.

- Thereafter, each player shall serve for 1 point in turn until the end of the game, and if the receiving player or pair makes 13 good returns in a rally, the receiver shall score a point.
- Introduction of the expedite system shall not alter the order of serving and receiving in the match.
- Once introduced, the expedite system shall remain in operation until the end of the match.

Scoring System

- A match shall consist of the best of any odd number of games.
- A game shall be won by the player or pair first scoring 11 points unless both the sides score 10 points each, when the game shall be won by the first player or pair subsequently gaining a lead of 2 points.

Fundamental Techniques of Table Tennis (Grip)

The racket can be held with two different types of grip.

- The penhold grip mainly used by Chinese and Japanese.
- Most commonly used grip is called 'shakehand' grip.

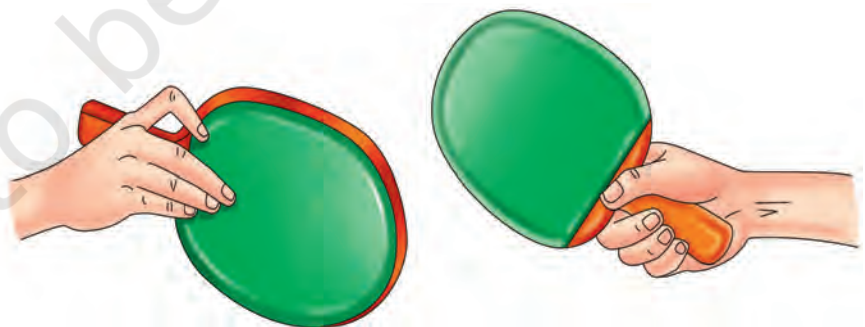

Fig. 4.52: Pen hold grip and shakehand grip (left to right respectively)

Service

There are different kinds of services that may be done from forehand or backhand such as long service, short service, flat service, spin service (side spin, back spin, top spin) low toss and high toss service.

Activity 4.12

Revise the fundamental skills of Table Tennis game.



Fig. 4.53: Backhand low toss service

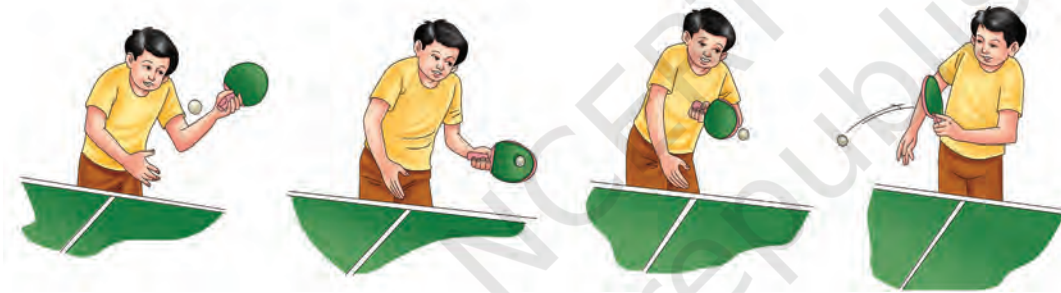

Fig. 4.54: Forehand service sequence (left to right respectively)

Types of Strokes

- There are offensive and defensive strokes played by a table tennis player including backhand and forehand.
- The offensive strokes in table tennis include drive, loop drive, loop, loop kill, hook, counter drive, flip and smash.
- The defensive strokes in table tennis include push, slice, block, drive, lob, drop shot and spin (side backhand top).

Most commonly used skill is forehand push, which can be played in the following way—

- This stroke is mainly used if a player cannot play a more aggressive attacking stroke.
- It is used when the opponent plays the ball short to the forehand with back spin. Right foot is the leading foot to return the ball with body weight transferred onto the right foot.
- The racket moves in a downward forward direction to contact the ball just in front of the body with slight follow through.

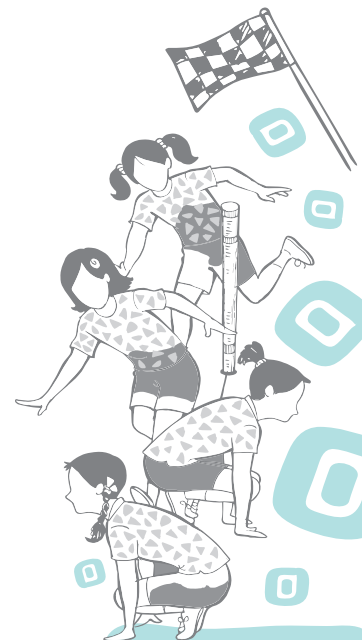

- The ball travels in upward direction from the racket.
- Initially the stroke is practised when there is little back spin on the ball from the opponent.

WRESTLING

Do You Know?

Vinesh Phogat is the first woman wrestler of India to win gold at Asian Games.

Activity 4.13

Collect information about the wrestlers of India and their achievement at international wrestling.

History

Wrestling has a prominent place in the Olympic Games and considered as one of the oldest forms of combat. It is believed that pictures of combating sports like wrestling were depicted in 15,000-year-old cave drawings found in France. Early Egyptians and Babylonians were also believed to be using the same techniques for the purpose of exhibiting their superiority over others. Wrestling was also very popular in Greece. It was developed by ancient Greeks as a way to train soldiers in hand-to-hand combat and military exercises. As per records found in the history of wrestling, it was year 1888 when the first national wrestling tournament was hosted at New York City. During the first Olympic Games, only one event in free style wrestling was introduced. It was until Saint Louis Olympic Games in 1904, where the free style wrestling competition was hosted in five categories. In 1908 Olympic Games, Greco Roman wrestling was also introduced in five weight categories but the number was increased up to eleven categories in later years. The International Federation of Associated Wrestling Styles (FILA) was founded in the year 1912 at Antwerp, Belgium. Norway hosted the first world women's wrestling championship in the year 1987 and women wrestling was included in the Olympic Games 2004.

Wrestling in India

Wrestling has been popular in India since ancient times; it was mainly an exercise to stay physically fit. The wrestlers, traditionally, use to wear a linen cloth called *Langota*. The real name which was used for the technique similar to wrestling in India was Malla Yuddh. One of the premier characters of the epic *Mahabharata* was Bhima, he was considered to be a great wrestler of that time. Jarasangha, Duryodhana, Karna and Balarama were included as other great wrestlers during *Mahabharata*. In an other Indian epic *Ramayana*, Hanuman is described as one of the greatest wrestlers of all time.

Governing Body

The governing body of the wrestling game at international level is known as United World Wrestling (UWW). Earlier, wrestling



game was governed by International Amateur Wrestling Federation, meant basically for the amateur wrestlers. Wrestling game in India is governed by a controlling body named Wrestling Federation of India (WFI), which was registered on 27th January, 1967 under the Society Act 1960 of the Government of India. The Wrestling Federation of India is the national governing body for the regulation of wrestling in India.

Types of wrestling

Free style

Free style is a type of wrestling in which holds on whole body parts are allowed. Free style wrestling was one out of total nine events that were included in the first Olympic Games 1896.

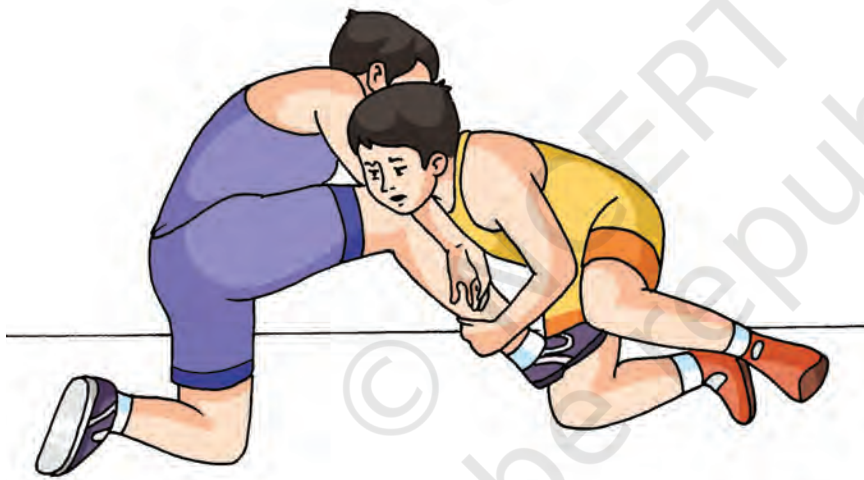

Fig. 4.55: Free style wrestling

Greco-Roman

The Greco-Roman type of wrestling forbids holds below the waist; this is the major difference between Greco-Roman and freestyle wrestling. Greco-Roman is an international sport that was contested at the first modern Olympic Games in 1896 at Athens as an exhibition sport. Greco-Roman style of wrestling has been included in every edition of the summer Olympics held since 1908. Two wrestlers are scored for their performance in two minutes bout for three periods. A wrestler can also win by pinning down (or fall) the opponent without completing the full time bout or periods. Women's wrestling was added to the summer Olympics, in 2004, at St. Louis (Missouri), USA.

Do You Know?

Sakshi Malik won a bronze medal at Summer Olympic Games in the year 2016.

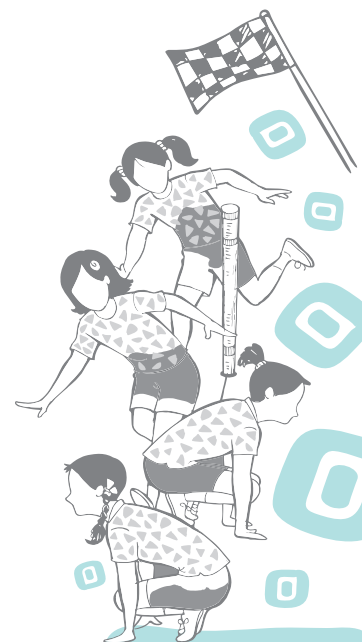



Fig. 4.56: Greco-Roman wrestling

Fundamentals of Wrestling

Weight Categories

There are different weight categories in wrestling for various age groups, at school level as well as at senior level. Wrestlers in the junior age category are allowed to participate in the competitions at senior level. However, in order to take part at senior level competition, wrestlers aged 18 in the concerned year must provide a medical certificate and parental authorisation. Wrestlers aged 17 in the year in question may not participate in senior competitions. Weight categories are classified for the purpose of giving equal opportunity to every wrestler competing in the competition. Wrestling competition organised at international level for different age groups are:

School Boys: 14–15 years

Cadets: 16–17 years

Juniors: 18–20 years

Seniors (Under 23): 19–23 years

Seniors: Above 20 years

Table 13: Weight Categories up to Junior level

S. No.	School Boys	School Girls	Cadet Boys	Cadet Girls	Junior Boys	Junior Girls
1.	29–32	28–30	39–42	36–38	46–50	40–44
2.	35	32	46	40	55	48
3.	38	34	50	43	60	51
4.	42	37	54	46	66	55
5.	47	40	58	49	74	59

6.	53	44	63	52	84	63
7.	59	48	69	56	96	67
8.	66	52	76	60	96–120	67–72
9.	73	57	85	65		
10.	73–85	57–62	85–100	65–70		

Table 14: Weight Categories up to Junior level

S. No.	Senior (Freestyle)	Olympic (Freestyle)	Senior (Greco-Roman)	Olympic (Greco-Roman)	Women (Freestyle Olympic)
1.	57	57	59	59	48/48
2.	61	65	66	66	53/53
3.	65	74	71	75	55
4.	70	86	75	85	58/58
5.	74	97	80	98	60
6.	86	125	85	130	63/63
7.	97		98		69/69
8.	125		130		75/75

Table 15: New weight categories (boys) described by School Games Federation of India (SGFI) (from 2018–19)

Under 14 (Freestyle Boys)	Under 17 (Freestyle and Greco-Roman Boys)	Under 19 (Freestyle) Boys	Under 19 (Greco-Roman) Boys
35	41–45	57	55
38	48	61	60
41	51	65	63
44	55	70	67
48	60	74	72
52	65	79	77
57	71	86	82
62	80	92	87
68	92	97	97
75	110	125	130

Costume of a Wrestler

Singlet

Contestants must appear on the edge of the mat, wearing an approved one-piece singlet of the colour assigned to them (red or blue). It is forbidden to have a mixture of red and blue colours on the singlet.

Activity 4.14

Collect information about Arjuna award winners in wrestling and discuss about the participation of Indian women in wrestling.

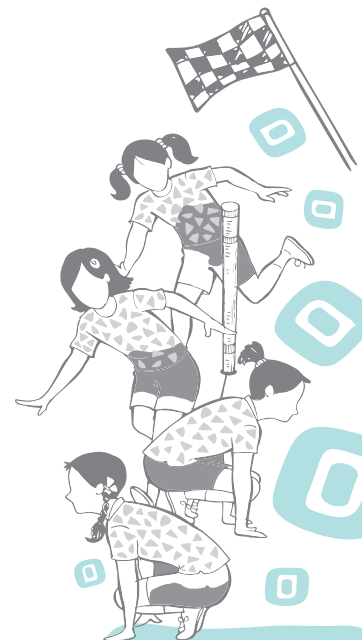

Ear protectors

If the wrestlers want, they can wear ear protectors, which must be approved by United World Wrestling (UWW) and must not contain any metal or have hard shells. The referee can oblige a wrestler whose hair is too long, to wear ear protectors.

Wrestling shoes

Contestants must wear wrestling shoes, providing firm support for the ankles. The use of heels in shoes, nailed soles, shoes with buckles or any metallic part is prohibited.

Measurement of Wrestling Arena

The following measurements and wrestling terms are used to designate the various parts of the wrestling mat:

- The central circle indicates the middle of the mat, which is one meter in diameter.
- The orange circle in the central surface of wrestling mat is called central wrestling area and is 7 meters in diameter, from the inside measurement.
- The orange strip is 1 meter wide.
- The area outside the orange circle is called protection area, which is 1.5 meter wide.
- In all cases, the colour of the protection area will have to be different from the one of the mat.

The coach of each athlete will be present in the same side of the mat. The red wrestler will be placed on the left side and the blue wrestler on the right side.

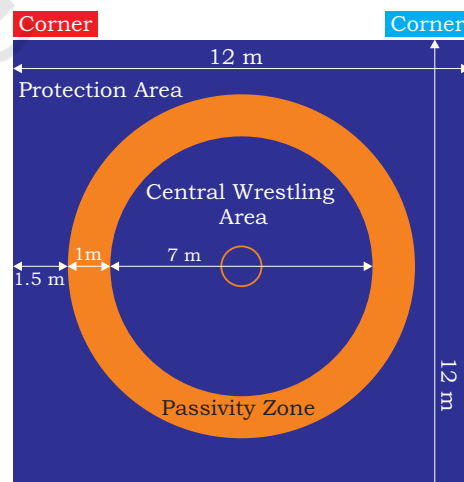

Fig. 4.57: Wrestling mat

Rules

The rules for wrestling usually change with the type of wrestling game being played. For instance, in Greco-Roman



Wrestling, players cannot hold an opponent below the waist, but holding legs is generally allowed in Freestyle Wrestling.

Prohibitions

- Wrestling styles forbid the use of martial arts' tactics. Strikes and kicks aren't permitted.
- It is prohibited to wear the emblem or abbreviation of another country in the wrestling costume.
- It is prohibited to apply any greasy or sticky substance to the body.
- It is prohibited to arrive at the mat perspiring at the beginning of the match and at the beginning of each period.
- It is prohibited to wear bandages on fingers, wrists, arms or ankles except in the case of injury and on doctor's orders. These bandages must be covered with elastic straps.
- It is prohibited to wear any object that might cause injury to the opponent, such as rings, bracelets, prosthesis, piercing, etc.
- It is prohibited to wear under-wired bras for women wrestler.

Classification of points

- The prime objective of Olympic Wrestling is to put your opponent on their back or to pin the opponent to the ground. This is only applicable if any part of the shoulder or both shoulder blades of the opponent contact the mat for at least a period of two seconds.
- To encourage risk-taking during bouts, a wrestler who may unsuccessfully try to execute a hold but ends up in the 'parterre' position (hands and knees on the ground), the wrestler on above will not be awarded any point. However, during a hold, if a defending wrestler initiates a counter-attack successfully, points would be awarded for the action.
- Three points are given to the near fall position for the player who gets the opponent to fall down but can't pin down completely. These points are given when shoulders of the opponent are within 4 inches of the mat (for at least 2 seconds) or when one shoulder touches the mat and the other is at 45 degree angle or when the wrestler is in high bridge.
- An offensive wrestler can also get a point in 'danger position'. A 'danger position' is the position when a defensive wrestler's body assumes bridge position in order to be avoided being pinned down. A 'danger

Activity 4.15

Collect information about Dronacharya awardees and their contribution to Indian Wrestling.

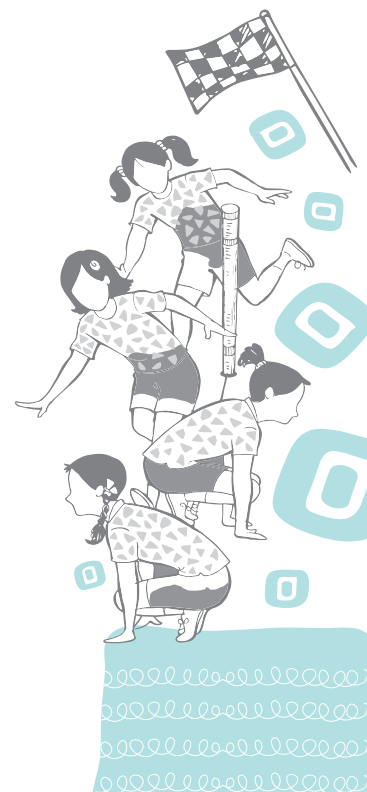

Do You Know?

The first wrestler of India to win a medal at Olympic Games was Khashaba Dabasaheb Jadhav in 1952.

Activity 4.16

Collect information about budding wrestlers through Khelo India Programme.

position' is considered when the wrestler's line of the back or shoulder is vertical or parallel to the mat, forming an angle of less than 90 degrees, but the position is assumed only to resist the fall.

- Points are awarded for the following—

Takedown: Up to 2 points are awarded if the opponent is taken down on the mat and the other player is controlling them.

Escape: Up to 1 point is given to a player who gets away from the mat or gets into a neutral position when pinned down.

Reversal: 2 points are given to the player who gains control of the opponent from underneath them.

Near fall: 2 points if the fall lasts for two seconds or 3 points if it lasts for 5 seconds.

Penalty Points: Up to 2 points for illegal holds, and technical violations like going off the mat, grabbing clothing, locking or overlapping hands.

Caution to a Wrestler

Caution is given to the wrestler for the following actions during the competition—

- For fleeing the mat, fleeing a hold, refusal to start, and illegal hold be noted by awarding (0).
- After each caution (0), the opponent will automatically receive two points in Greco-Roman wrestling.
- After each caution (0), the opponent will automatically receive one or two technical points in Freestyle wrestling depending on the gravity of the infraction.
- In Greco-Roman wrestling, no point is granted to the opponent when a wrestler is warned for the second time for passivity.
- Offensive wrestler can get a penalty to lock hands (except cradles) around the torso of the defensive wrestler.
- It can only be done if the opponent is standing on their feet or close to the fall count.
- A referee will consider overlapping fingers as locked hands.

Technical Violation

The referee can penalise the wrestler for the technical violation of the following rules—

- Going off the mat or forcing your opponent off the mat to avoid wrestling.
- Leaving the mat during the match without the referee's permission.



- Reporting to the mat not properly equipped or not ready to wrestle, or with the illegal equipment at the time of starting the match.
- Bringing roughness in the game unnecessarily.
- Conducting oneself indecently.
- Incorrect starting position or false start.

Activity 4.17

Collect information about all the Indian wrestlers who won medals at Olympic Games.

Points on Technical Violation

- The first and second time wrestler is penalised, the opponent is awarded point.
- The third time wrestler is penalised, the opponent is awarded 2 points.
- The fourth time the wrestler is penalised with disqualification from that bout.

Duration of the Bout

- For school boys and cadets—two periods of 2 minutes with a 30 seconds break.
- For juniors and seniors—two periods of 3 minutes with a 30 seconds break.
- For all the competitions, the timing should be displayed on the scoreboards and shall start from 0 to 6 minutes for seniors and 0 to 4 minutes for schoolboys and cadets.

Criteria to Win

- A bout may be won by fall, withdrawal by injury, default, disqualification of the opponent, or by technical superiority through points.
- In case of tie by points, the winner will be declared by successively considering—the highest value of holds; the least amount of cautions; and the last technical point(s) scored.
- If nobody gets pinned, the wrestler who scored the most points during the match is declared as a winner.

Match Officials

In all competitions, the refereeing for each bout shall consist of—

- Mat Chairman
- Referee
- Judge

Some of the great wrestlers produced by India are Master Chandgi Ram, Satpal, Kartar Singh, Ombir Singh, K.D. Yadav, Palwinder Singh Cheema, Sushil Kumar, Yogeshwar Dutt, Geeta Phogat, Narsingh Yadav, Babita Kumari, Vinesh Phogat, Babita Kumari, Sumit Malik, etc.

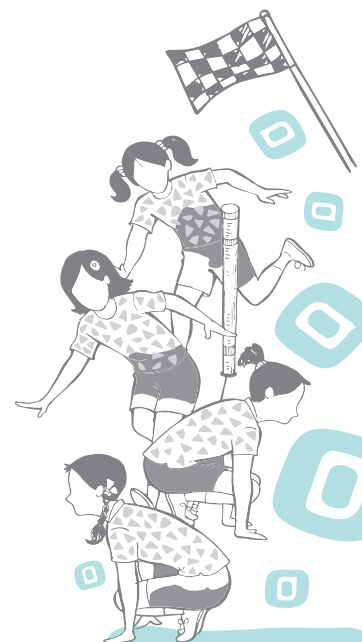

ASSESSMENT

ATHLETICS

I. Long Answer Questions

1. Explain the meaning and history of athletics.
2. Describe the events organised in athletics.
3. Describe the classification of track events in athletics.
4. Describe the classification of field events in athletics.
5. Enlist the different types of throw events. Explain shot put throw in detail.
6. Enlist the different types of jump events. Explain high jump in detail.
7. Explain the types of crouch start in short distance running.

II. Short Answer Questions

1. What is the distance of runway in long jump and triple jump?
2. What is the size of landing area in high jump?
3. Name any four throwing events.
4. Name the famous technique used for high jump.
5. What is relay?
6. What is the weight of discus for men and women?
7. Which type of track is called a standard track?
8. What is the weight of the shot in shot put for men and women?

III. Fill in the Blanks

1. The thickness of the take-off board in long jump and triple jump is _____.
2. Maximum weight of the crossbar in high jump is _____.
3. The _____ of shot put in women is 4 kg.
4. 28 hurdle jumps and 7 water jumps are there in _____.

IV. State whether True or False

1. 400 m track is known as standard track.
2. 5 runners participate in a relay race.
3. Bunch start is a throwing technique.
4. Disco put style is applied in discus throw.
5. There are two types of tracks.



BADMINTON

I. Long Answer Questions

1. Write the history of Badminton in Olympics.
2. Write various types of events played in Badminton.
3. Write the dimensions of the Racket.
4. Draw a labelled badminton court.

II. Short Answer Questions

1. Who won India's first Olympic medal in Badminton?
2. What is the legal height a badminton player is allowed to serve from?

III. Fill in the Blanks

1. Weight of a shuttle should be _____.
2. Height of the badminton court for international competitions shall be _____.
3. The colour of the lines of badminton court should be _____.

IV. State whether True or False

1. Thomas Cup was first held in 1956.
2. In badminton, doubles A side has only one service.
3. A 60 seconds interval between each game is allowed.
4. A player can win a game with a score of 30–28 points.
5. High serve is used sometimes in badminton men's singles.



GYMNASTICS

I. Long Answer Questions

1. Explain the history of gymnastics in Olympics.
2. Explain the evolution of gymnastics in India.
3. How many types of gymnastics are there? Enlist the men's and women's apparatus used in artistic gymnastics.
4. Write down the specifications of uneven bars and pommel horse.
5. Enlist some advanced skills in gymnastics and explain the process of 'Cartwheel on Balancing Beam'.

II. Short Answer Questions

1. When was the gymnastics introduced in the Olympic Games?
2. Who is considered as the father of modern gymnastics?
3. How many events are there in Artistic Gymnastics for men?
4. What is the full form of F.I.G.?
5. When did women compete for the first time in Olympics?
6. In which year did Nadia Comaneci received the first perfect score in Olympics?

III. Fill in the Blanks

1. Gymnastics begun in ancient Greece about _____ years ago.
2. Today, gymnastics is often termed as the ultimate combination of _____.
3. Nadia Comaneci was the first female gymnast who received perfect score in 1976 at _____ Olympics.
4. Like any other sport, gymnastics is a physical exercise that develops agility, coordination and _____.

IV. State whether True or False

1. Gymnastics is an Olympic sport.
2. There are three events in women Gymnastics.
3. Roman rings is a men's apparatus.
4. Balancing beam is an apparatus for men.
5. Floor exercise is an apparatus for both men and women.



JUDO

I. Long Answer Questions

1. Explain the history of Judo.
2. Describe the basic rules of Judo.
3. Explain about the emergence of Judo in India.
4. Explain the measurement and specifications of the contest area in Judo.

II. Short Answer Questions

1. Where did Judo come from?
2. What is the difference between Judo and Jujutsu?
3. What are the working principles of Judo?
4. What is Kuzushi?
5. What is Kiai?
6. What are the Judo ranks?
7. Who created Judo?
8. What are the main types of Judo techniques?

III. Fill in the Blanks

1. The two types of penalties awarded in Judo are _____ and _____.
2. The competition area of Judo is a minimum of _____.
3. Judo was introduced in Olympic Games in _____ in Tokyo only in female category.

IV. State whether True or False

1. Judo was included in the Asian Games in 1986.
2. Judo was introduced in Olympic Games in 1964 in Tokyo only in male category.
3. The contest area is of different colour from the safety area.
4. Contest occurs under the supervision of a referee and two judges.



SWIMMING

I. Long Answer Questions

1. Explain the world and Indian history of swimming.
2. Write about the most renowned swimmers of India.
3. Explain the teaching stages of front crawl stroke.
4. Explain the teaching stages of back crawl stroke.

II. Short Answer Questions

1. When was the first swimming association formed?
2. Discuss about SFI within 50 words.
3. Explain the dimensions of a standard swimming pool?
4. What is the difference between freestyle and breast stroke?

III. Fill in the Blanks

1. _____ °C to _____ °C is the normal range of temperature for water in swimming pool.
2. In a standard pool, there are _____ lanes.
3. Grab is a type of _____ in swimming.
4. Jellyfish is a type of _____ in swimming.

IV. State whether True or False

1. During the relay, we can change the swimmer of a team.
2. During breast stroke, if the swimmer is tired he/she can use freestyle swimming.
3. Back stroke in swimming starts from the water level.
4. During one's turn, the swimmer is allowed to touch the floor.



TABLE TENNIS

I. Long Answer Questions

1. Briefly write the history of Table Tennis.
2. Briefly write the scoring system in Table Tennis.
3. Write about the expedite system in Table Tennis.
4. How many types of strokes are there in table tennis? Explain.

II. Short Answer Questions

1. How does a standard Table Tennis game end?
2. Besides the green colour? Which colour table can be used for the table?
3. What should be the height of the ball when tossed for the service?
4. Which country has won the most international titles in the 20th century?
5. What is the size of Table Tennis table?

III. Fill in the Blanks

1. In Table Tennis, penhold grip is used by _____ players.
2. Diameter of the Table Tennis ball shall be _____ mm.
3. Table Tennis became an Olympic sport in _____.
4. Height of the table from the floor is _____.

IV. State whether True or False

1. Table Tennis was included in Asian Games in 1958 in Tokyo.
2. Table Tennis racket may be of any size, shape or weight.
3. Table Tennis Federation of India was established in 1924.
4. Table Tennis is an indoor game.



WRESTLING

I. Long Answer Questions

1. Differentiate between freestyle and Greco-Roman wrestling in detail.
2. Draw the labelled diagram of a wrestling playing mat.
3. Discuss different age and weight categories in wrestling for male and female.
4. Discuss the various ways of winning points by a wrestler.

II. Short Answer Questions

1. List down the match officials in wrestling.
2. Who was the first wrestler to win an Olympic medal?
3. What are the two types of wrestling styles?
4. What is the name of the governing body of wrestling in India?
5. What does WFI stands for?
6. What is the term used for wrestling costume?
7. What is the major difference between Greco-roman and free style wrestling?

III. Fill in the Blanks

1. The first national wrestling championship under WFI was held in _____.
2. Passivity zone is of _____ m in width.
3. First Indian male medallist in Olympics was _____.
4. First Indian woman medallist in Olympics was _____.
5. _____ is the only Indian wrestler to win two medals at the Olympics Games.

IV. State whether True or False

1. The registered office of wrestling federation of India is located in UT of Delhi.
2. Women wrestlers participated first time in Olympics after the gap of 100 years of their male counterpart.
3. In freestyle wrestling, the techniques are used only above the waist.
4. Wrestling is a combat sports originated from Martial Arts.
5. Weight categories in Greco-Roman and freestyle are same.





TEAM GAMES

5

Any game which provides opportunities to two or more players working together towards a shared objective is called a team game. A team game is an activity in which individuals are organised in a team to compete with the opposing team, in accordance with a set of laws/rules to win. Games like Basketball, Cricket, Football, Handball, Hockey, Volleyball, etc., are some of the classic examples of major team games.

However, over a period of time, the popularity of team games has grown continuously. These games have positively influenced not just the players, but also their fans, local and national economies. All over the world, the impact of team games can be seen resulting in professional players to live out their dreams. Star players have become role models to youth. Young athletes/players develop life skills which are followed as footsteps of their role models.

In this chapter, some of the team games like Basketball, Cricket, Football, Handball, Hockey, Kabaddi, Kho-Kho, and Volleyball are explained.

BASKETBALL

Basketball is a team game played between two teams of five players each, on the court. Very high amount of energy (calories) expenditure is there in this game. It also helps in building bone and muscle strength and boosts the immune system. This game also develops self-discipline and concentration among young players.

History

Basketball originated in the United States of America and was invented by Dr. James Naismith in December, 1891, who was a Physical Educator at the International Young Men's Christian Association Training School (YMCA) (now known

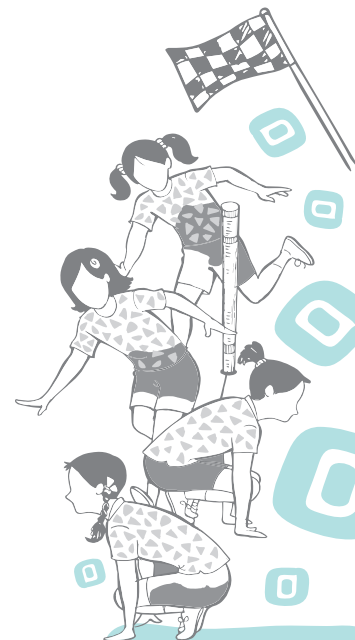

as Springfield College of Physical Education) in Springfield, Massachusetts.

Do You Know?

On January 15 1892, the first set of rules of the Basketball game were published by Dr. James Naismith in the college magazine, "Triangle", under the title "A New Game".



Fig. 5.1: Dr. James Naismith

Naismith sought a vigorous indoor game to keep his students occupied and at proper levels of fitness. But after rejecting many ideas, he obtained a soccer ball and two wooden peach baskets. He hung the baskets on the railing of the balcony at the height of 10 ft above the floor at the opposite ends of the gym hall. The objective of the game was to toss the soccer ball into the peach baskets. The first basketball game was played among physical education students with nine players on each side, of Springfield secretarial training class of Physical Education (PE) College in December, 1891.

The International Basketball Federation FIBA (French acronym: Federation Internationale de Basketball) association was founded in Geneva in 1932. Basketball was featured in the St. Louis, Missouri, United States, III Olympic Games in 1904. It was officially recognised as an Olympic game in 1936 in Berlin. Due to the wide popularity, Basketball was played in the first Asian Games in 1951 held at New Delhi.

History of basketball in India

Basketball was introduced in India by American missionaries towards the end of the first decade of 20th century. It was presumed that in the year 1905, the game of basketball was started at the YMCA Calcutta by H. Peterson and J.N. Guaj. The credit of starting and popularising this game goes to YMCA College of Physical Education, Madras in the year 1920. The first National Basketball Championship was organised in 1934 by the Indian Olympic Association and later after the



constitution of Basketball Federation of India (BFI) in 1950 at Mumbai, the First National Basketball Championship under the banner of BFI was held at Ludhiana (Punjab) in 1951.

Measurement of playgrounds, and field and specifications of equipment

Playing court

The playing court shall have a hard and flat surface, free from obstructions with dimensions of 28 m in length and 15 m in width measured from the inner edge of the boundary lines and free space atleast 2 m on all sides.

Boundary lines

These lines are not part of the playing court. The centre line is marked parallel to the endlines from the mid-point of the sidelines. The extended centreline at sidelines (5 cm) divides the court in two halves. It consists of a Back court (team's own basket area) and a Front court (consists of the opponents' basket). All lines are drawn 5 cm in width and in clearly visible white colour. The centre circle shall be marked in the centre of the playing court and have a radius of 1.80 m measured to the outer edge of the circumference. If the inside of the centre circle is painted, it must be the same colour as of the restricted areas.

Do You Know?

- Late C.C. Abraham, professional Physical Education Leader, from Y.M.C.A. College of Physical Education, Chennai and Meher Singh of Rajasthan were the founder, president and secretary of Basketball Federation of India (BFI).
- Wheelchair Basketball was developed in USA by a badly injured army person after the Second World War around 1946. The rules are approximately similar to Basketball.

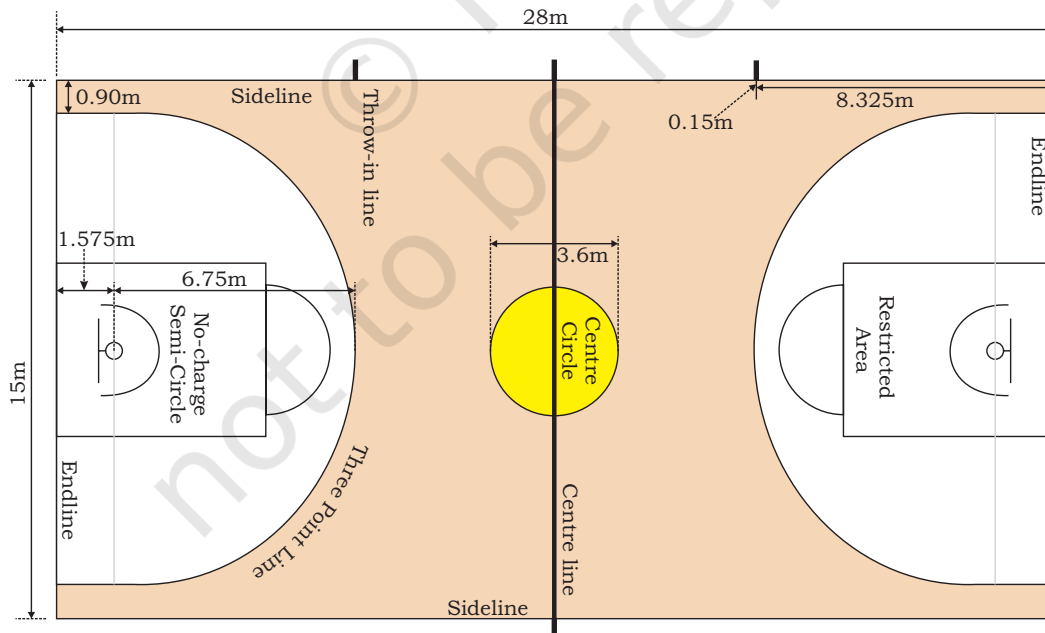
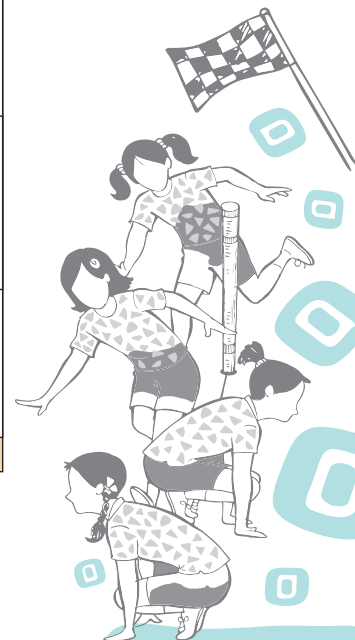

Fig. 5.2: Basketball court



Do You Know?

- Side line and end line of Basketball court is 28m in length and 15m in width respectively.
- Back support poles are 2 m away from the end lines.
- The height of the ring from floor is same as it was when Basketball was originated.

Free-throw lines, restricted areas and free-throw

The free-throw lines are drawn parallel to each end line. It shall have its farthest edge 5.80 m from the inner edge of the end line and shall be 3.60 m long. Its mid-point lies on the imaginary line joining the mid-point of the two end lines.

The restricted areas are the rectangular areas marked on the playing court limited by the end lines, the extended free-throw lines and the lines which originate at the end lines. Their outer edges being 2.45 m from the mid-point of the end lines, terminate at the outer edge of the extended free-throw lines. These lines, excluding the endlines, are part of the restricted area. The inner side of the restricted areas must be painted in one colour. The freethrow semi-circles marked on the playing court with a radius of 1.80 m measured to the outer edge of the circumference and with their centres at the mid-point of the free-throw lines.

- 3 points can be scored by shooting the ball into the opponents' basket from the entire court but from outside of the 3 point line.
- 2 points can be scored by shooting the ball into the opponents' basket, if the shot is taken from inside the 3 point line.
- Only 1 point can be scored by single free shots.

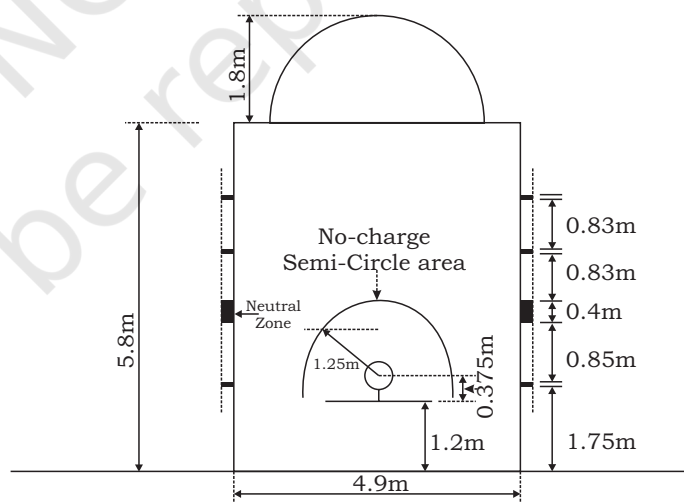

Fig. 5.3: Restricted area in basketball

Equipment

The following equipment will be required—Backstop units (backboards, comprising rings and nets, backboard support structures including padding), basketballs, game clock, scoreboard, shot clock, stopwatch or suitable (visible) device (not the game clock) for timing and time-outs, two separate

distinctly different and loud signals, one each for the shot clock operator and scorer/timer, scoresheet, player foul markers, and team foul markers.

Backboard

The backboards (1.80 m horizontally and 1.05 m vertically) shall be made of a suitable transparent material, made in one (1) piece, non-reflective, with a flat front surface. All lines on the backboards shall be white, 50 mm in width. The rings shall be made of solid steel and shall have an inside diameter of a minimum of 450 mm and a maximum of 459 mm. The nets (400 mm to 450 mm in length) shall be made of white cord with 12 loops to attach it to the ring.

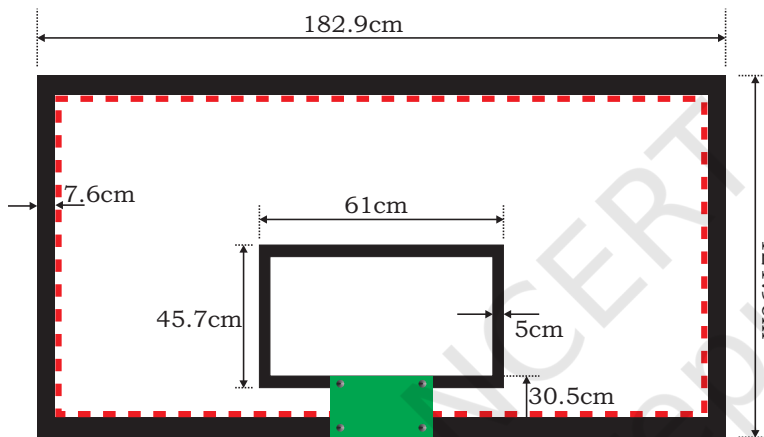

Fig. 5.4: Basketball backboard

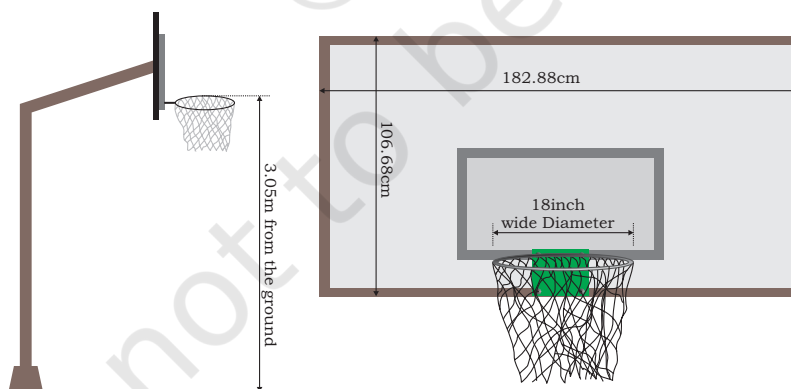
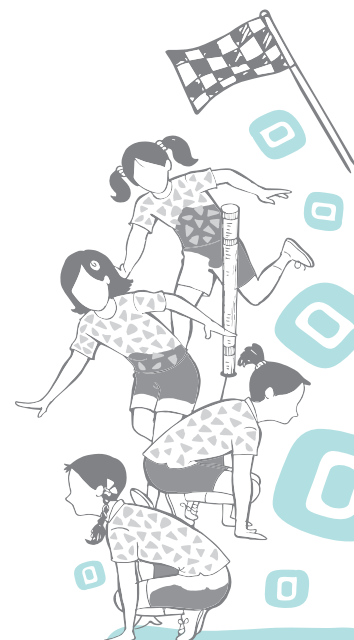

Fig. 5.5: Basketball backboard and rim dimensions

Basketball

The ball shall be spherical, with black seams not exceeding 6.35 mm in width and, either of a single shade of orange or of



Do You Know?

First time Indian women's team participated in Bangkok Asian Game in 1978.

International Basketball Federation (FIBA) approved colour combination and made of leather/artificial/composite/synthetic leather/rubber. For all men's and women's competitions, the basketball specifications are given in the following table and diagram.

Table 1: Basketball dimensions according to category

Category	Size	Circumference	Weight
Men	7	749–780mm	567–650g
Women	6	724–737mm	510–567g

Functional Rules of Basketball

Basketball is governed by FIBA official rules. The aim of each team is to score in the opponent's basket and to prevent the other team from scoring. The team that has scored the greater number of points at the end of playing time is declared as the winner.

Team

In a match, two teams compete with each other. Each team shall consist of not more than 12 team members entitled to play, including a captain who represents his team on the playing court. During playing time, five players from each team shall be on the playing court, without this a game cannot begin. Teams may use as many substitutions as. A maximum of five team support staff members who may sit on the team bench and have special responsibilities, e.g., manager, doctor, physiotherapist, trainer, statistician, interpreter, etc., besides a coach and, if a team wishes, it can have an assistant coach also. Player's positions are given in the diagram below.

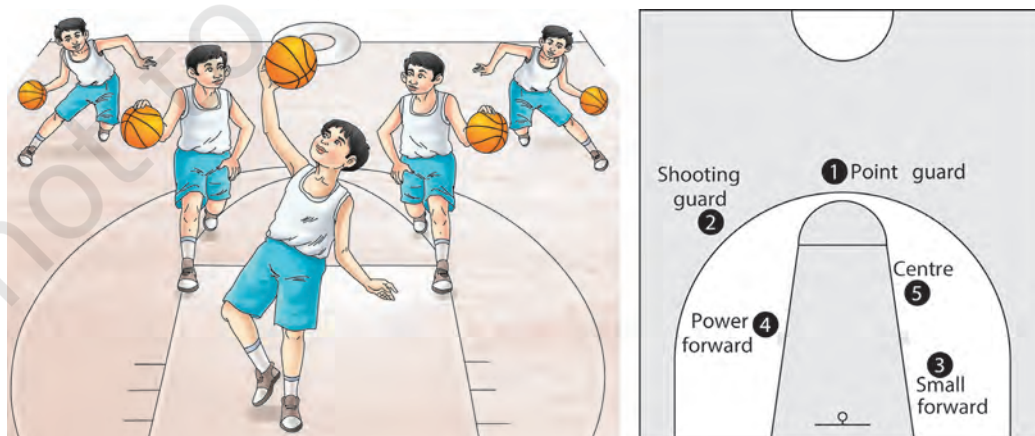

Fig. 5.7: Players, position (right), attack, defence (left)

Opponents' Own Basket

The basket that is attacked by a team is the opponents' basket and the basket which is defended by a team is one's own basket.

Uniforms

The 'All-in-ones' uniform of the team members shall consist of—Jersey of the same dominant colour on the front and back and numbered on the front and back at least 10 cm high in front and 20 cm high in back with at least 2 cm width. All players must tuck their Jersey into their playing shorts. Shorts end above the knee, of the same dominant colour at front and back, but not necessarily of the same colour as the jersey. Socks of the same dominant colour for all players of the team. Teams must have a minimum of two sets of jersey (light/dark). Chest number will be from 0 to 99 or 00.

Officials, table officials and commissioner

The officials shall be a referee and 1 or 2 umpire(s). They shall be assisted by the table officials and by a commissioner, if present. The table officials shall be a scorer, an assistant scorer, a timer and a shot clock operator. Different signals are used to run the game by officials. Each foul and goal shall be mentioned in the scoresheet.

Playing time, tied score and extra periods

The game shall consist of 4 periods of 10 minutes each. There shall be intervals of 2 minutes between the first and second quarter (first half), between the third and fourth period (second half) and before each extra period. There shall be a half-time interval of play of 15 minutes. If the score is tied at the end of playing time for the fourth period, the game shall continue with as many extra periods of 5 minutes as is necessary to break the tie.

Beginning and end of a period or the game

The first period begins when the ball leaves the hand(s) of the referee on the toss for the jump ball and followed. All the other periods start when the ball is disposed to the players by the officials for the throw in.

How the ball is played

A game of basketball is played with hand(s) only and may be passed, thrown, tapped, rolled or dribbled in any direction, subject to the restrictions of the rules.

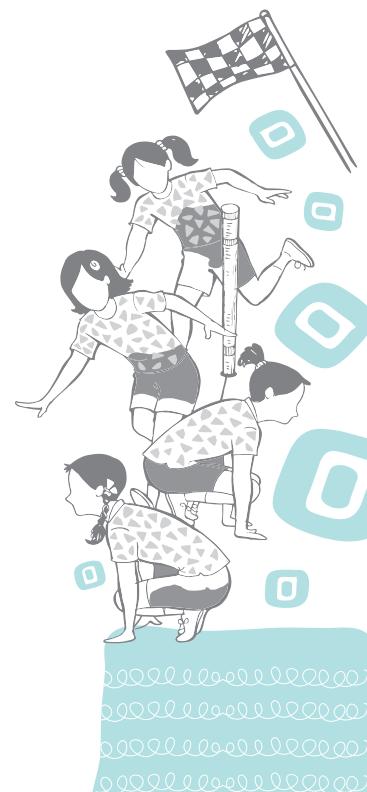

Goal

A basket scored from inside the three-point area (also called 2 point field goal area) is worth of 2 points. A basket scored from beyond the three-point area (3 point field goal area) is awarded 3 points. A basket scored for the free-throw is worth of one point for each successful attempt.

Time-out

Each time-out shall last 1 minute. Each team may be granted two time-outs during the first half, three time-outs during the second half with a maximum of two of these time-outs in the last 2 minutes of the second half. One time-out during each extra period is also given.

Substitution

A team may substitute a player(s) during a substitution opportunity when the game clock is stopped and the ball becomes dead.

Game Lost by Forfeit and default

The game is lost by a team if the team is absent or unable to present with five players on the court, or by their action to prevent the game in scheduled time, or if they refuse to play. In this situation, the opponent team is declared winner by 20-0.

The game may be lost by default when a team has fewer than two players during the running game at the playing court. The opponent team is declared winner by 2-0.

Violations

A violation is an infraction of the rules. There are different types of violation that occurs during the game.

- 1. Player out-of-bounds and ball out-of-bounds:** A player is out-of-bounds when any part of his body is in contact with the sideline or endline.
- 2. Dribbling:** A dribble starts when a player, having gained control of a live ball on the playing court, throws, taps, rolls, dribbles it on the floor or deliberately throws it against the backboard and touches it again before it touches another player. A dribble ends when the player touches the ball with both hands simultaneously or permits the ball to come to rest in one or both hands.
- 3. Time Rule:** Three seconds—A player shall not hold the ball in the opponents' restricted area with live ball for more than continuous 3 seconds.



- Five seconds—A player may not hold the ball for more than 5 seconds.
- Eight seconds—A team has to go into the opponents' court within 8 seconds.
- Twenty four seconds—When a team gains possession of the ball, they have to attempt the shot within maximum of 24 seconds.

4. Back court: A team which is in control of live ball in its front court may not cause the ball to be illegally return to its back court.

Activity 5.1

Find out the information about Wheelchair Basketball and share it with classmates.

Fouls

A foul is an infraction of the rules concerning illegal personal contact with an opponent and/or unsportsmanlike behaviour. A number of fouls may be called against a team. Once a team has made four fouls in a period, each next foul will award two free throws to the opponent team. Fouls categorised as personal foul, technical foul, unsportsmanlike foul, disqualifying foul and noted as individual player foul or team fouls.



Fig. 5.8: An offensive foul

- 1. Personal foul:** A personal foul occurs when there is illegal contact between two opponents. A player shall not hold, block, push, charge, trip or impede the progress of an opponent by extending the body part, neither in an 'abnormal' position nor shall the player indulge in any rough or violent play. A player who commits more than five personal fouls is excluded from the game.
 - (a) Charging: An offensive foul that is committed when a player pushes or runs over a defensive player. The ball is given to the team upon which the foul was committed.

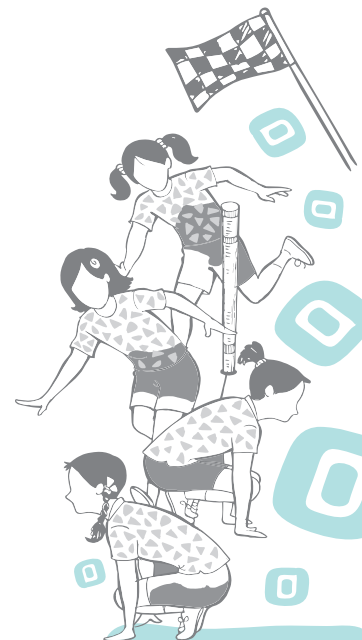

(b) **Blocking:** It is an illegal personal contact, which impedes the progress of an opponent with or without the ball.

2. Technical Foul: It is a non-contact foul of a behavioural nature (disregarding warning, disrespectful, foul language, delay, etc.).

3. Unsportsmanlike foul: It is a foul where spirit of the game or the hard contact is made.

4. Disqualification Foul: It is any unsportsmanlike (violence) action by players, coaches or delegation members.

Irrespective of the penalty, each foul shall be charged, entered on the score sheet against the offender and penalised accordingly. All the possible foul penalties against players on the playing court involved in fighting or any situation which leads to a fight shall be dealt with in accordance of rules.

Basic Skills of Basketball

Basketball is played with the help of different skills and techniques like stance, footwork, ball holding and handling, dribbling, passing-receiving, shooting and rebounding. Few are mentioned here.

Dribbling

It is important to move the ball across the court, get away from defensive players, make or find a good passing line, make use of faking action, 1 on 1 and of course to penetrate the ball to score the goal. There are different types of dribbling which may be learnt and developed with the help of different drills in stationary and moving positions with or without the defensive player.

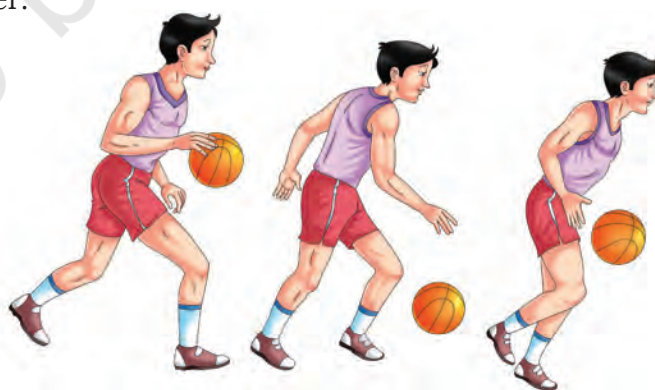

Fig. 5.9: Dribbling

- Stationary dribble
- Low dribble
- High dribble

- Change of pace dribble
- Crossover dribble
- Behind the back dribble
- Between the legs dribble
- Speed dribble
- Reverse spin dribble

Passing and Receiving

A good offensive attack requires accurate passing and receiving. It helps to speed the ball, find an open man, to find a good shooter or to get away the ball from the defender. Fake and feint are used to increase the quality of passing. There are different types of passing using one or both hands during different stationary and moving group and team drills.

- Chest pass
- Overhead pass
- Push pass
- Bounce pass
- Shoulder pass
- Hook pass
- Off the dribble pass
- Baseball pass

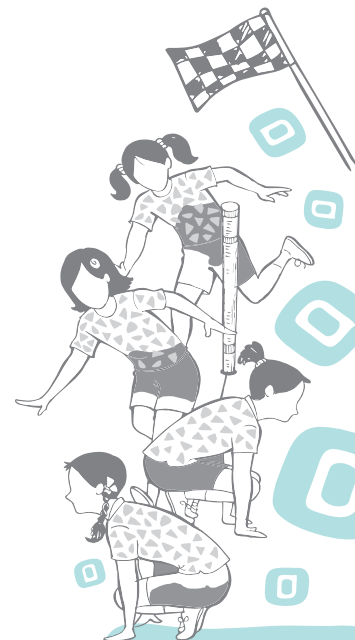

Fig. 5.10: Passing and receiving

Shooting

The objective of the game is to win by scoring maximum points. Therefore, improving the team's shooting is important to win a game. Shooting by either one or both hands may be done in the following ways:

- Jump Shot
- Dunk Shot
- Free Throw
- Layup
- Three point shot



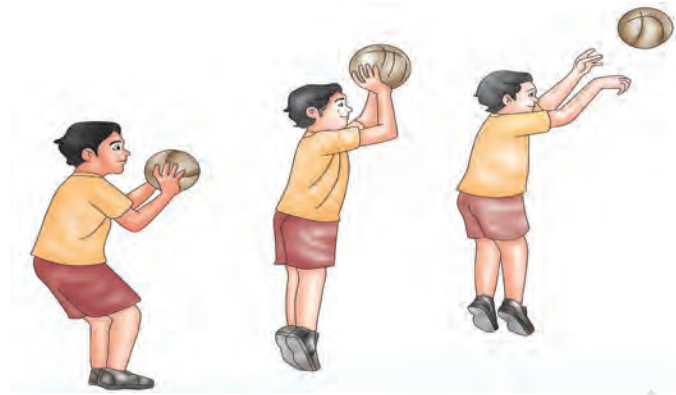

Fig. 5.11: Shooting

Rebounding

The objective of rebounding is to successfully gain possession of the basketball after a missed field goal or free throw, as it rebounds from the ring or backboard. This plays a major role in the game, as most possessions end when a team misses a shot. There are two categories of rebound—offensive rebound, in which the ball is recovered by the offensive side and does not change possession, and defensive rebound, in which the defending team gains possession of the loose ball. The majority of rebound is defensive, as the team on defence tend to be better positioned to recover the missed shots.



Fig. 5.12: Rebounding

Defence

The game of basketball allows a variety of defences to be deployed in an effort to disrupt and combat the offensive plays. Here are examples of the three basic categories of team defence. In addition, each category consists of an assortment of different variations.

- 1. Man to man defence:** Man to man defence is usually assigned to be matched up with the defenders against specific offensive players. Defenders are usually assigned to be matched up with the offensive players by size and ability.
- 2. Zone Defence:** In zone defence, defenders are assigned to guard specific areas on the court. Zones are named or designated by their player alignments.



Fig. 5.13: Zone defence

- 3. Combined Defence:** The third type of defence that can be deployed is the combination defence. With combination defence, some of the players are assigned to play man to man while the rest of the defenders play zone defence. Combination defences are usually deployed in an effort to stop or neutralise great individual offensive players.

Awards in Basketball

To motivate the extraordinary achievements of the player and coaches, the Government of India honours players with different awards along with cash prizes and certificates.

Prasanthi Singh was honoured with Arjuna Award in 2017 and she is the first basketball player who received the prestigious civilian award Padma Shri in 2018.

Famous Indian Basketball Players

Paramjeet Singh, Sarabjit Singh, Vishesh Bhriuwanshi, Tridep Rai, Suman Sharma, Divya Singh, Anitha, I.V. Chairian, Satnaam Singh, Jagdeep Singh, Gurvinder Singh, and Shri Khusi Ram.

Do You Know?

Basketball is also played by three players on each side.

Activity 5.2

- What is the air pressure of a Basketball?
- When and where was the first Basketball match in Olympic Games played?
- Who invented Basketball?
- Why is the colour of basketball orange?
- What is the size and weight of a basketball?

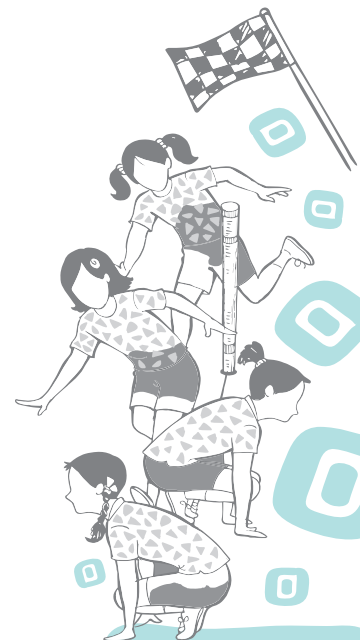

CRICKET

Playing any game need strength and vice versa helps in building strength. Cricket also, through the constant running across the field, helps in increasing the stamina, balance, hand-eye coordination, flexibility and ball-handling skills. Cricket includes a lot of throwing and sprinting across the field, which is a good cardiovascular activity.

History

A reference of a game resembling to cricket is there in the records of King Edward I, in 1300 being played at Kent. Cricket as a game was first recorded in 16th century in England. Researches show that the game evolved from a very old, widespread game to pass time in which one player served a small piece like a ball made up of wood or any other material and another player hit it with a suitable item. The first recorded cricket match took place in Kent in 1646. Cricket was popular and widely documented in England during the 1700s. After 1760, the game saw the evolution of over arm bowling by replacing under arm bowling. The Marylebone Cricket Club (MCC) was formed on 31st May, 1787. After a year, it laid down a code of laws regarding the game. Its laws were adopted throughout the game. MCC today remains the custodian and arbiter of laws relating to cricket around the world. Thereafter, cricket recognisably became the game that is played today. In the 1800, cricket had reached the West Indies and India and in the 19th century cricket was played in South Africa and New Zealand. The first international cricket game was played between the USA and Canada in 1844. The match was played at the grounds of St George's Cricket Club in New York. In 1877, an England touring team in Australia played two matches against full Australian XIs that are now regarded as the inaugural test matches.

History of Cricket in India

Cricket is undoubtedly one of the most popular games in India since its inception. The first Indian Cricket club, named the Parsee Oriental Cricket Club, was founded in the year 1848 and they played their first match in Bombay (Mumbai). From this point, the journey of Indian cricket began. The first international exposure in the history of Indian Cricket came in the year 1926. In the same year, a team from the Marylebone Cricket Club (MCC) toured India. Though it was an unofficial tour, Indian people were quite interested and enthusiastic about the matches that MCC played during the tour.



The legendary Indian cricket player, C.K. Naidu played brilliantly during that tour and he also scored a century against the MCC in Bombay. Imperial Cricket Conference (ICC), now International Cricket Council, was formed on 30 November, 1907. At present there are 105 countries as members of ICC. The Board of Control for Cricket in India (BCCI) was established in the year 1928. India played its first test match against England in 1932. Now cricket is played to cover all the three formats, ranging from 5 Day tests, to the exciting one-day 50 over format, and the 20 over format which is called as T20.

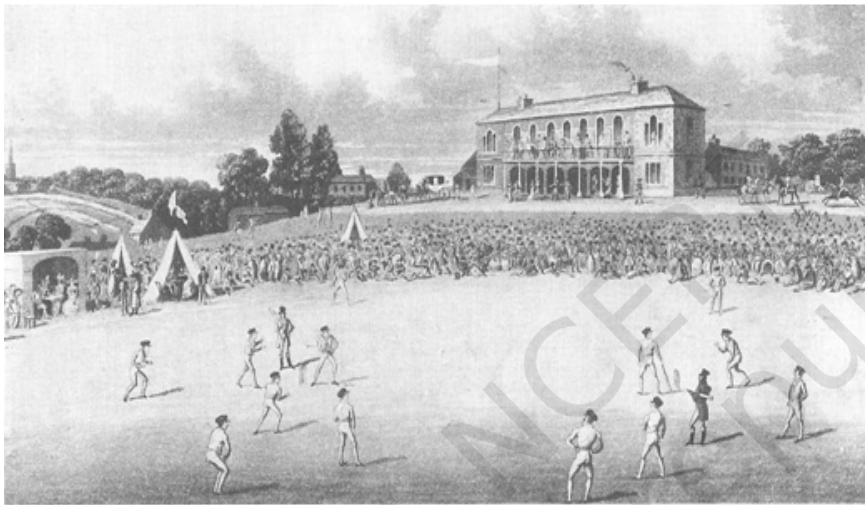

Fig. 5.14: Cricket in the early ages

Functional Rules

Cricket has many laws, more than any other game. Cricket is played with a bat and ball on a large field, known as ground. It is played between two teams having 11 players each. There is also a reserved player called a 'twelfth player', who is used if any player is injured during the play. The twelfth player is not allowed to bowl, bat, or to act as wicketkeeper or captain of the team. The twelfth player is only to act as a substitute fielder.

The objective of the game is to score runs with the bat by the batsman, or dismiss the opposing batsman when in the field by the bowlers. The cricket laws are for the traditional form of cricket which is called 'Test Cricket'. However, there are separate rules for one day and T20 format game also.

Do You Know?

India won the 60 over World Cup beating West Indies in 1983, 50 over World Cup defeating Sri Lanka in 2011 and 20 over World Cup beating Pakistan in 2007.

Activity 5.3

Gather and share information about the first Indian team of test match, one day match and T20 match in male and female categories.

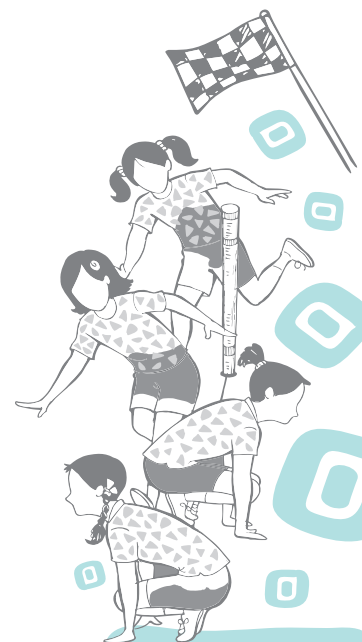

Number of Players in a team	11 (Playing) + 05 (Extras) = 16
Number of Officials	03 Umpires, 01 Match Referee, 02 Scorers
Length of the Bat	38 inches (965 mm)
Width of the Bat	4.25 inches (108 mm)
Weight of a Cricket Ball	155.9 gms – 163 gms
Circumference of a Ball	22.4 cm – 22.9 cm
Colour of a Ball	Red (Day Matches and Test Matches) White (Day Night Matches)
Length of the Pitch	22 yds or 20.12 mts or 66 feet
Width of the Pitch	3.05 mts or 10 feet
Height of the Stumps	28 inches (With bails 28.5 inches)
Width of the Stumps	9 inches (22.9 cm)

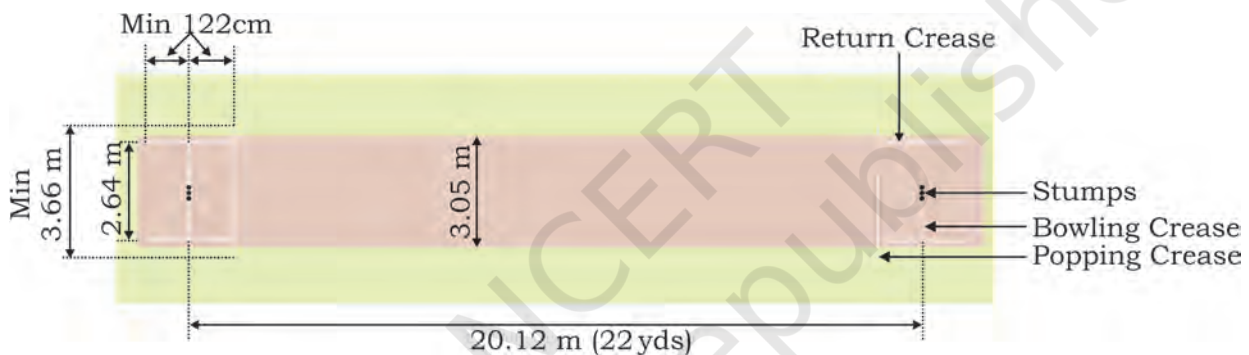

Fig. 5.17: Cricket pitch measurements

There are two ground umpires and a third umpire. Their role is to ensure in the ground that the game is played as per the preambles and laws. The third umpire is in charge of the video decisions.

Game Structure: Test cricket is a game that spans for two or more innings. This means that one team needs to bowl and the other would do batting. If a team is out twice or scores less runs in two innings, than that team is the losing team.

Before the game begins, an umpire tosses a coin. The captain who guesses the correct side of the coin will then choose whether to bat or field first.

How to play Cricket

- One team will bat while the other team will field.
- If the bowler bowls the ball from the wrong place or the ball is either dangerous or bounces more than twice or rolls before reaching the batsman or if fielders are standing at illegal positions, it is called 'No Ball'.

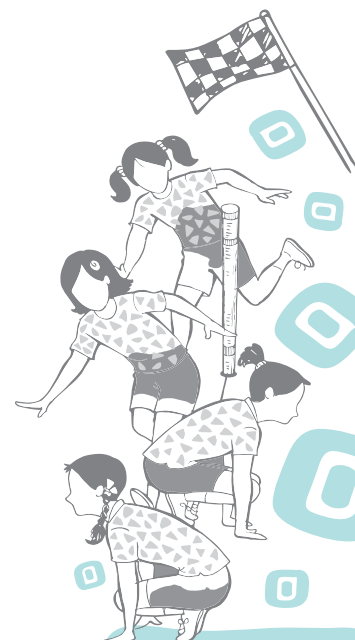

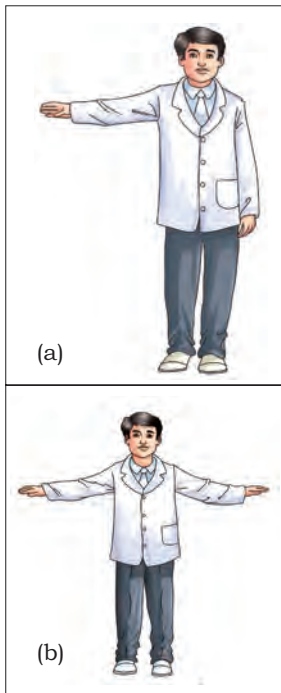

Fig. 5.18: (a) No ball
(b) Wide ball

The batsman can hit a no ball and score runs and also cannot be declared out from a no ball except if the player is run out or hit the ball twice, or obstruct the field. A no ball will add one run to the batting team.

- A 'Wide Ball' is declared if the batsman did not have a reasonable opportunity to score off the delivery. As if the delivery is bowled over the batsmen's reach. A wide delivery will add one run to the batting team.
- A 'Bye' run is scored when a batsman is trying to hit the ball but could not hit it and is miss-field by the fielder or wicket keeper.
- A 'Leg Bye' run is scored if while hitting, the batsman misses to hit the ball by bat and is deflected by striker's body or protective gear.

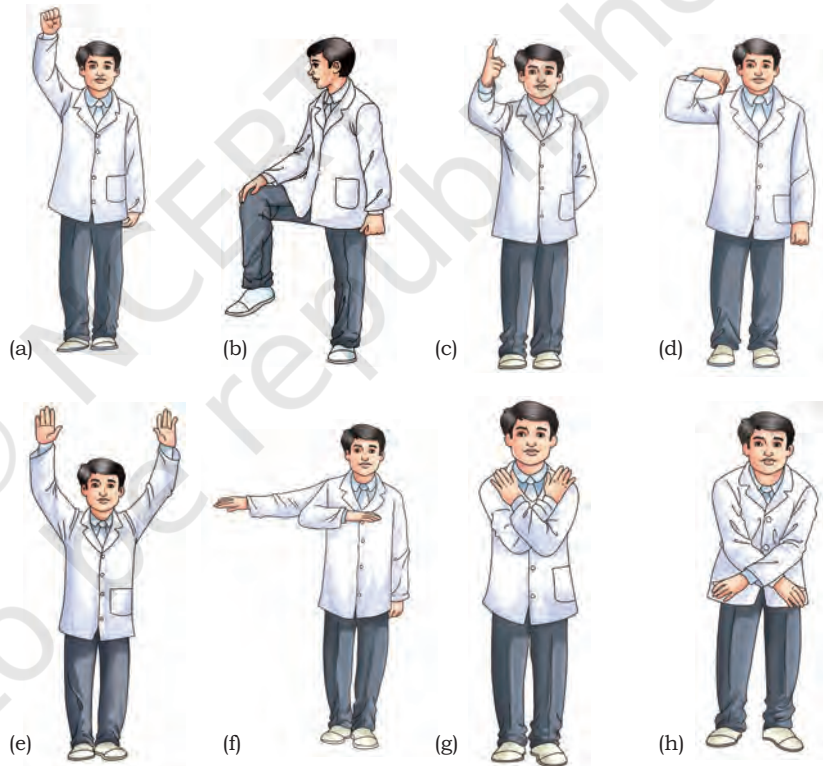

Fig. 5.19: (a) Bye (b) Leg bye (c) Out (d) Short run (e) Six
(f) Four (g) Decision change (h) Dead ball

When is a Batsman declared 'out' as per cricket rules?

There are 11 ways through which a batsman can be given "out" in the game of cricket.

- **Bowled:** If the ball is bowled and hits the striking batsman's wickets, the batsman is given out (as long as at least one bail or stump is dislodged by the ball).



It does not matter whether the ball has touched the batsman's bat, gloves, body or any other part of the batsman.

- **Caught:** If a batsman hits the ball or touches the ball at all with the bat or hand holding the bat and the fielders, or wicket keeper or bowler catches the ball, it is called as caught out.
- **Stumped:** A batsman can be given out when the wicketkeeper puts down the wicket while the player is out of the crease and not attempting a run (while attempting a run it would be a run out) but trying to play the ball and misses it.

Activity 5.5

- Draw and discuss the different positions of the fielders in cricket.

Do You Know?

There is no fix measurement for cricket's outer boundaries.



(a)



(b)

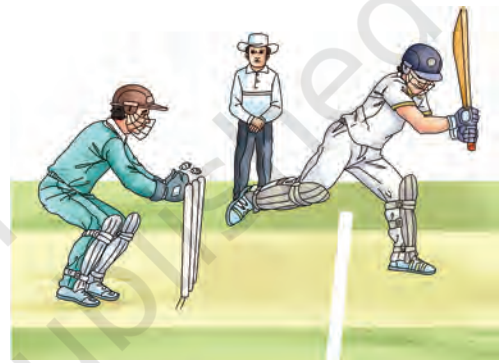

(c)

Fig. 5.20: (a) Bowled (b) Caught (c) Stumped

- **Leg Before Wicket (LBW):** If the ball is bowled (not a No Ball) and it hits the batsman first without touching the bat and umpire thinks and decide that the ball would have hit the wickets if the batsman was not there, then the LBW decision is possible. However, if the ball hits the batsman outside the line of off stump while the player was attempting to play a stroke then the player is not out.
- **Run Out:** A batsman is out if no part of the bat or body is grounded behind the popping crease while the ball is in play and the wicket is fairly put down by the fielding side.
- **Hit Wicket:** If a batsman hits the wicket down with the bat or body after the bowler has entered the delivery stride and the ball is in play, then the player is out.
- **Handled the Ball:** If the batsman willingly handles the ball with the hand that is not touching the bat without the consent of the opposition, then the player is declared out.

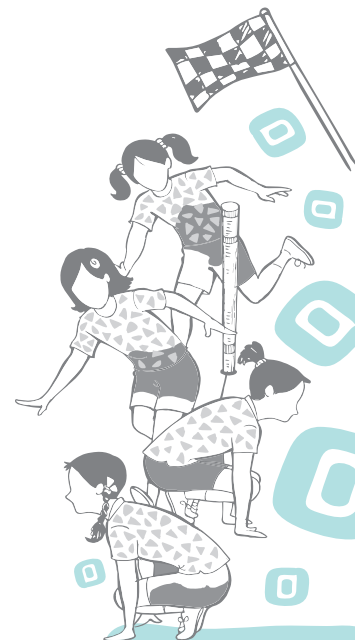

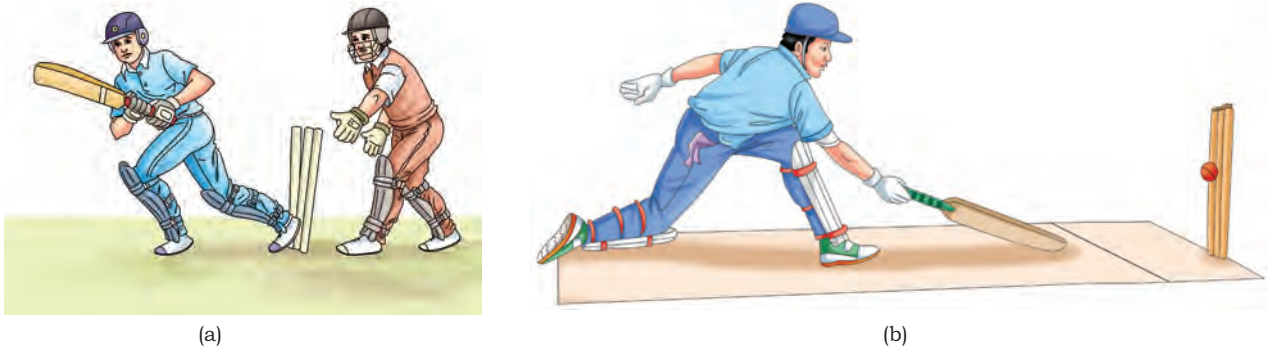

Fig. 5.21: (a) Hit wicket (b) Run out

Do You Know?

After Jim Laker of England, only Anil Kumble from India in 1999 took all 10 wickets in one inning (74/10 in 26.3 overs).

- **Obstructing the Field:** A batsman is out if he willingly obstructs the opposition by word or action.



Fig. 5.22: (a) Handled the ball (b) Obstructing the field

- **Timed Out:** The time for an incoming batsman to face a ball or be at the non-strikers end within three minutes of the outgoing batsman being dismissed. If this is not done, the incoming batsman can be given out.
- **Hit the Ball Twice:** If a batsman hits a ball twice other than for the purpose of protecting his wicket, he is out.
- **Retired:** If a batsman retires without the umpire's consent and also doesn't have the consent of the opposition captain to resume his innings, then technically he is out.

There are many other cricket laws. Many of the more advanced rules and laws can be learned along the way and are not vital to general play.



Awards in Cricket

To motivate the extraordinary achievements of the players and coaches, the Government of India honours players with different awards along with cash prizes and certificates.

In the year 2018

Virat Kohli received Rajiv Gandhi Khel Ratna Award in 2018. Smriti Mandhana was honoured with Arjuna Award. Tarak Sinha has been honoured with Dronacharya Award for an excellent contribution as a Coach.

FOOTBALL

The history of football is over more than 1000 years old. Today, football is world's most favourite sport played in almost every country. Studies reveal about various games similar to the modern football being introduced in different parts of the world by different cultures for different purposes. Oldest version of football game is believed to be played in the villages of Chinese dynasty.

History of the Game

Both rugby and football have a common root. There were many who instead of kicking believed in running with the ball in their hands. Kicking the ball included tripping the legs without any legislation or rules to govern. On the contrary, many people stood for football with kicking as it involved greater mastery of ball. In football, high level of skill precision was required to control and manoeuvre the ball with foot. The rules of play were subsequently smoothed down and smartened to create organised sports at Britain and Scotland. It was at this point that the people spoke out against rough customs as tripping, shin-kicking and so on. As it happened, the majority also expressed disapproval at carrying the ball with hand. It was in 1863 in England that the Rugby football group withdrew and formed a separate branch. This further led to the development modern-day sports of 'Association Football', 'Rugby Football' and 'Gaelic Football' in Ireland. Later the Football Association in England was formed becoming the sports' first governing body. In 1904, 'Federation International de Football Association' (FIFA) was founded in Paris as an international governing body of football. The game of football in today's scenario is called 'Soccer'.

Do You Know?

- Football was essentially rugby until 1882.
- Football is the most watched and most played sport on earth.

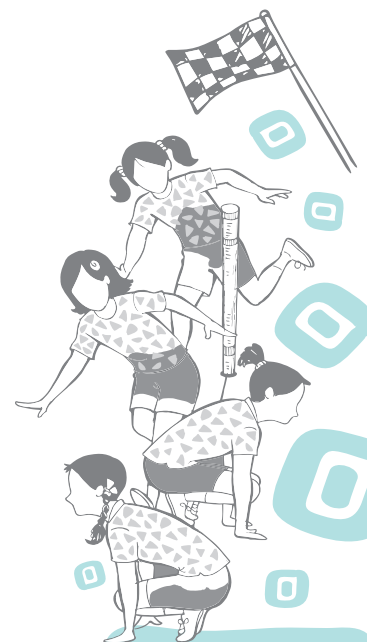

Do You Know?

Durand Cup started in the year 1888 in Shimla and it is the second oldest tournament in the world. Presently, this tournament is being organised in New Delhi every year with the help of Indian Defence Services.

Activity 5.6

Collect information about the various types of free kicks in football.

Modern football

Britain is regarded as the home to modern association football. Within Britain and Scotland, the game was popular from eight century and again played with different variations. In medieval times, towns and villages played against the rival towns and villages— and kicking, punching, biting and gouge were allowed. Hundreds of people took part and the games could last all day. It was same until the game started being promoted in schools in England as an integral part of the school curriculum. The need for uniform standards and rules acceptable to everyone was the need of the hour. This led to the role of Cambridge University in unifying the schools and the clubs to a meeting in 1863 for establishing common acceptable rules. Football Association Challenge Cup was started in 1872, which is regarded as the world's oldest football championship. In the year 1888, 'Durand Cup' was started in Shimla (India) and in modern time Durand cup for football is regarded as second oldest football tournament in the world. Later in 1904, FIFA (Federation International de Football Association) was formed with France, Netherlands, Belgium, Denmark, Sweden, Switzerland, Spain and Germany as the founder members.

History of Football in India

Football in India has been a popular sport introduced in nineteenth century by the British army, from the capital at Calcutta. Durand Cup started in 1888, founded by the then India's Foreign Secretary, Mortimer Durand at Shimla. Durand Cup is the third oldest football tournament after Football Association (FA) Cup and Scottish Cup. Clubs like Mohan Bagan, which is the oldest current team, was formed in 1889. Indian Football Association (IFA) Shield is the fourth oldest tournament in the world which was founded in 1893 and is still being played. Durand Cup was shifted to Delhi. Since 1950, every year it is organised under the supervision of Indian Army.

Before the birth of the All India Football Federation (AIFF) in 1937, India was lacking a constituted national organisation for football. Since, football gained immense popularity year after year, a need for the proper administration of the game was considered. The association that governed football in West Bengal, Indian Football Association (IFA), was given the status of the de-facto governing body of football. That time all the foreign tours of Indian football team were organised by IFA. AIFF was affiliated to FIFA (international governing body of football) in 1948 and to Asian Football Confederation (AFC) in 1954. AIFF has played a key role in promoting



football in India. To serve the purpose, it has taken the responsibility of Indian national football team. National Football League (I-League), Federation Cup and National Football Championship for Santosh Trophy are some of the prominent football tournaments being organised by the AIFF.

Activity 5.7

Find out the measurements of the football ground in your school or nearby school in your vicinity.

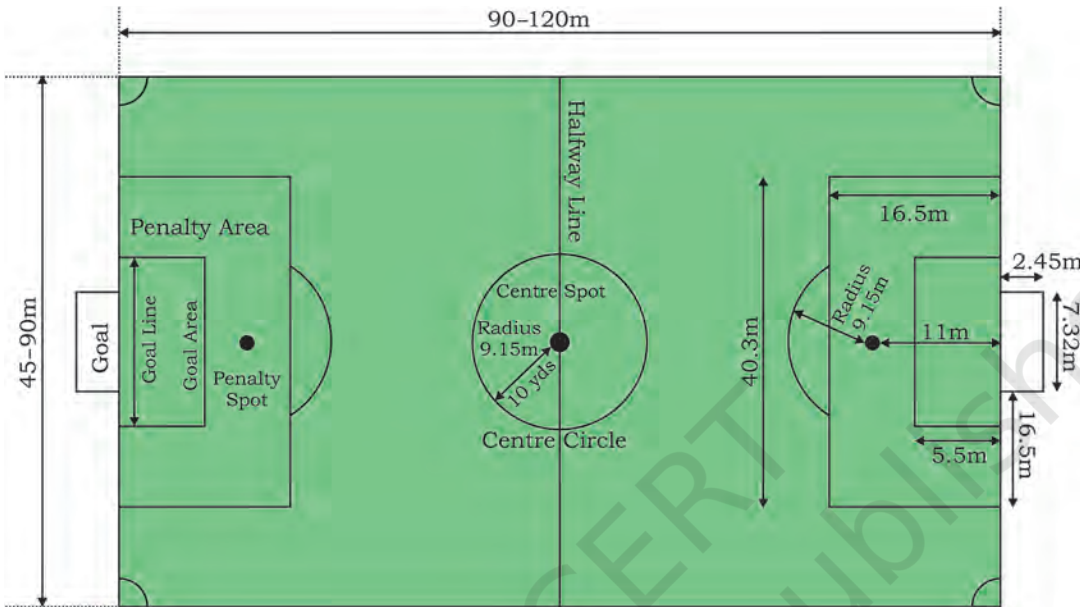

Fig. 5.23: A football ground

Laws of football

In the game of football, rules are called Laws and there are 17 Laws of football that govern the game. FIFA is the governing body of football around the world. It governs the rules for playing the sport. The referees are being trained for consistent interpretation and quality enforcement of the 17 laws of the game. There are 17 laws of the game which are the codified rules of help define association football.

Law 1

The Field of Play: It mentions about the field surface along with the dimensions for field marking. The field of play should be rectangular in shape and the width should not exceed the length of the field.

Table 2: Dimensions

Length (Touch Line)	Minimum	90 mt	100 yds
	Maximum	120 mt	130 yds
Width (Goal Line)	Minimum	45 mt	50 yds
	Maximum	90 mt	100 yds

Do You Know?

Neil Armstrong wanted to take a football to the moon, but NASA refused it as nothing extra was allowed.

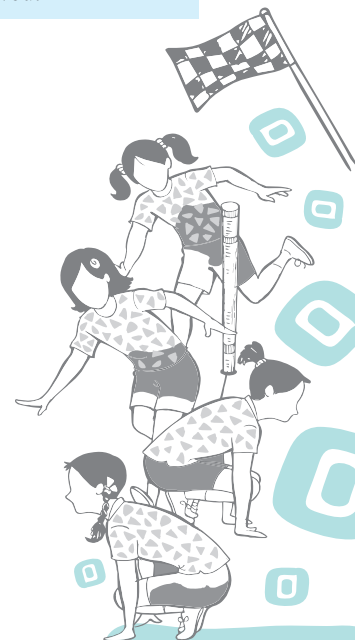



Fig. 5.24: Football equipment

Table 3: International Matches

Length (Touch Line)	Minimum	100 mt	110 yds
	Maximum	110 mt	120 yds
Width (Goal Line)	Minimum	64 mt	70 yds
	Maximum	75 mt	80 yds

FIFA defines minimum dimensions of 45m × 90m and maximum dimensions of 90m × 120m for a standard football ground. FIFA has also set measurements for minimum football ground for the official matches or international competitions as 64m × 100m and maximum to 75m × 110m.

Law 2

Ball: The football must meet the following criteria as per the FIFA laws—

- The ball shall be spherical in shape.
- It should be made of leather or any other suitable material approved by the governing body.
- Ball circumference shall be 68 to 70 cm which is equal to 27 to 28 inches.
- The weight of the ball shall be between 410 to 450g which is equal to 14 to 16 oz at the start of the match.
- Air pressure should be equal to 0.6–1.1 atmosphere (600–1,100 g/cm²) at sea level.

Law 3

Number of Players: A match is played by two teams. Each team shall consist of not more than 11 players during the match, one of whom shall act as goalkeeper. A match may not start if either team consists of fewer than seven players.

Substitutions: Up to a maximum of three substitutes may be used in any match played in an official competition organised under the auspices of FIFA or the member associations. For all other competitions, the rules of the competition must state how many substitutes may be nominated, it can vary from three up to a maximum of twelve, before the tournament begins.

Law 4

Players' Equipment: The basic compulsory equipment of a player comprises the following items:

- A jersey or shirt with sleeves:* If undergarments are worn, the colour of the undergarments must be of same colour as the sleeve of the jersey or shirt.
- Shorts:* If undershorts or tights are worn, these must be of same colour as the shorts.

- (c) *Stockings*: If tape or similar material is applied externally, it must be of same colour as that part of the stocking to which it is applied.
- (d) Shin guards
- (e) Shoes

Law 5

Referee: Each match is controlled by a referee, who shall enforce the Laws of the Game. Duties of a Referee:

- (a) Enforces the Laws of the Game.
- (b) Controls the match in cooperation with the assistant referees (Line Judges) and, wherever applicable, with the fourth official (Table Official).
- (c) Ensures that the ball used meets the requirements of Law number 2.
- (d) Ensures that the player's equipment meet the requirements according to Law number 4.
- (e) Acts as timekeeper and keeps a record of the match.
- (f) Stops, suspends or abandons the match, for any infringements of the Laws.
- (g) Stops, suspends or abandons the match because of outside interference of any kind.
- (h) Stops the match if, in his opinion, a player is seriously injured and ensures that player is removed from the field of play. An injured player may only return to the field of play after the match has restarted.
- (i) Allows the play to continue until the ball is out of play if a player is, in his opinion, only slightly injured.

Law 6

Assistant Referees: The decision of the assistant referee is always subject to the decision of the referee. However, two assistant referees are appointed, whose duties, are to indicate:

- (a) when the entire ball leaves the field of play.
- (b) which team is entitled to a corner kick, goal kick or throw-in.
- (c) when a player may be penalised for being in an offside position.
- (d) when a substitution is requested.
- (e) when misconduct or any other incident occurs out of the view of the referee.
- (f) when offences have been committed whenever the assistant referees have a better view than the referee (this includes, in certain circumstances, offences committed in the penalty area).

Do You Know?

Soccer is the universal name of the Football game. It is governed by the rules formed by FIFA.

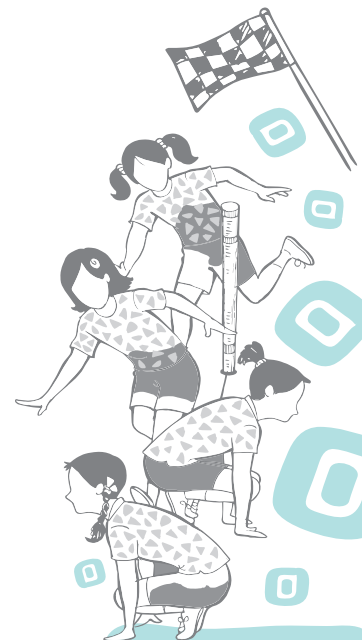

Activity 5.8

Collect information about the kick off in football.

- (g) Whether, at penalty kicks, the goalkeeper moves off the goal line before the ball is kicked and if the ball crosses the line.

Law 7

Duration of the Match: The match lasts two equal periods of 45 minutes, unless otherwise mutually agreed between the referee and the two teams. Any agreement to alter the duration of the periods of play (e.g., to reduce each half to 40 minutes because of insufficient light) must be made before the start of play and must comply with competition rules. The half-time interval must not exceed 15 minutes.

Law 8

Start and Restart of Play: A kick-off is a way of starting or restarting play—

- (a) At the start of the match.
- (b) After a goal has been scored.
- (c) At the start of the second half of the match.
- (d) At the start of each period of extra time, wherever applicable.

A goal may be scored directly from the kick-off. The procedure for the kick-off is by pushing the ball in any direction by one of the team mates but all the team members must be in their own half before the kick-off. The team winning the toss chooses the side to attack while the losing team gets the kick-off. In the second half, the team that won the toss gets the kick-off.

Law 9

Ball In and Out of Play: The ball is out of play when:

- (a) It has wholly crossed the goal line or touch line whether on the ground or in the air.
- (b) Play has been stopped by the referee.

The ball is in play at all other times. Ball will also be in play when:

- (c) It rebounds off a goalpost, crossbar or corner flag post and remains in the field of play.
- (c) It rebounds off either the referee or an assistant referee when they are on the field of play.

Law 10

Method of Scoring: A goal is scored when the whole of the ball passes over the goal line between the goalposts and under the crossbar, provided that no infringement of the



Laws of the game has been committed previously by the team scoring the goal.

Law 11

Offside: It is not an offence in itself to be in an offside position. However, players in offside position cannot make themselves on-side until the course of the ball changes.

A player is in an offside position if—

- (a) The player is nearer to the opponents' goal line than both the ball and the second-last opponent.

A player is not in an offside position when:

- (i) The player is in their own half of the field of play, or
 - (ii) The player is level with the second-last opponent, or
 - (iii) The player is level with the last two opponents.
- (b) There is no offside offence if a player receives the ball directly from—
 - (i) a goal kick
 - (ii) a throw-in
 - (iii) a corner kick

Law 12

Fouls and Misconduct: For not following the Laws of the game, the referee can penalise the team members through a—

- (a) Direct Free Kick
- (b) Penalty Kick
- (c) Indirect Free Kick

The referee may caution the player, substitutes or substituted players with a 'Yellow Card'. The referee may suspend the team members with a Red Card leading to suspension from the current match along with a second match suspension.

- (a) *A direct free kick:* It is awarded to the opposing team if a player commits any of the following seven offences in a manner considered by the referee to be careless, reckless or using excessive force.
 - (i) Kicks or attempts to kick an opponent
 - (ii) Trips or attempts to trip an opponent
 - (iii) Jumps at an opponent
 - (iv) Charges an opponent
 - (v) Strikes or attempts to strike an opponent
 - (vi) Pushes an opponent
 - (vii) Tackles an opponent

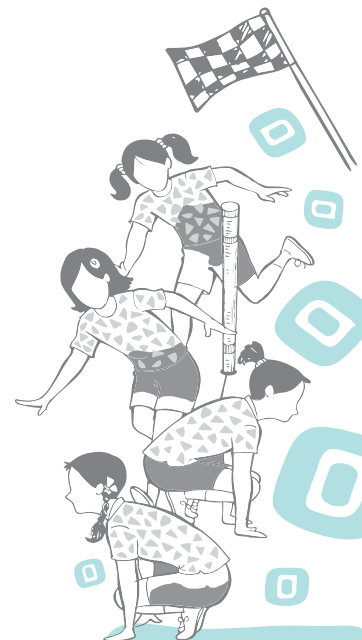

A direct free kick is also awarded to the opposing team if a player commits any of the following three offences.

- (i) Holds an opponent
 - (ii) Spits at an opponent
 - (iii) Handles the ball deliberately (except for the goalkeeper within the player's own penalty area)
- (b) A penalty kick: A penalty kick is awarded if any of the above ten offences is committed by a player inside their own penalty area, irrespective of the position of the ball, provided it is in play.
- (c) An Indirect Free Kick: An indirect free kick is awarded to the opposing team if a goalkeeper, inside their own penalty area, commits any of the following four offences:
- (i) Controls the ball with hands for more than six seconds before releasing it.
 - (ii) Touches the ball again with hands after the ball is released from his possession and before it has been touched by another player.
 - (iii) Touches the ball with hands after it has been deliberately kicked to the player by a team-mate.
 - (iv) Touches the ball with hands after receiving it directly from a throw-in taken by a team-mate.

An indirect free kick is also awarded to the opposing team if, in the opinion of the referee, a player—

- (i) Plays in a dangerous manner
- (ii) Impedes the progress of an opponent
- (iii) Prevents the goalkeeper from releasing the ball from the player's hands
- (iv) Commits any other offence, not previously mentioned in Law 12, for which the play is stopped to caution or send off a player.

The indirect free kick is taken from the place where the offence occurred.

Cautionable offences (Yellow Card): A player is cautioned and shown the yellow card if he commits any of the following seven offences:

- (i) Unsporting behaviour
- (ii) Dissent by word or action
- (iii) Persistent infringement of the Laws of the game
- (iv) Delaying the restart of play
- (v) Failure to respect the required distance i.e., 10 yards away from the ball, when play is restarted with a corner kick, free kick or throw-in



- (vi) Entering or re-entering the field of play without the referee's permission
- (vii) Deliberately leaving the field of play without the permission of referee.

A substitute or substituted player is cautioned with a Yellow Card if commits any of the following three offences:

- (i) Unsporting behaviour
- (ii) Dissent by word or action
- (iii) Delaying the restart of play

Sending-off offences (Red card): A player, substitute or substituted player is sent off by showing a 'Red Card' if they commit any of the following seven offences:

- (i) Serious foul play
- (ii) Violent conduct
- (iii) Spitting at an opponent or any other person
- (iv) Denying the opposing team a goal or an obvious goal scoring opportunity by deliberately handling the ball (this does not apply to a goalkeeper within their own penalty area)
- (v) Denying an obvious goal scoring opportunity to an opponent moving towards the player's goal by an offence punishable by a free kick or a penalty kick
- (vi) Using offensive, insulting or abusive language and gestures
- (vii) Receiving a second caution (yellow card) in the same match

A player, substitute or substituted player who has been sent off, must leave the vicinity of the field of play and the technical area.

Law 13

Free Kicks: Free kicks are of two types.

- (a) Direct free kick
- (b) Indirect free kick

Direct free kick: If a direct free kick is taken and it enters the goal:

- (a) If a direct free kick is kicked directly into the opponents' goal, a goal is awarded
- (b) If a direct free kick is kicked directly into the team's own goal, a corner kick is awarded to the opposing team.

A score cannot be made through an indirect free kick if taken straight way into the goal without touching any other player.

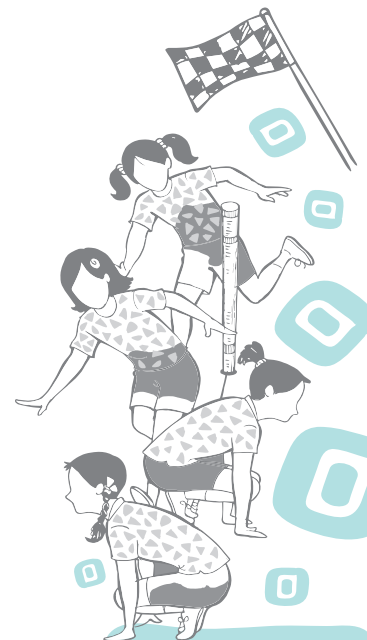

Do You Know?

A direct free kick, if kicked directly into the team's own goal, a corner kick is awarded to the opposing team.



Fig. 5.25: Free kick

Law 14

Penalty Kick: A penalty kick is given against a team that commits one of the ten offences inside its own penalty area while the ball is in play. A goal may be scored directly from a penalty kick.

During the penalty kick, all the players other than the kicker are located—

- (a) inside the field of play.
- (b) outside the penalty area.
- (c) behind the penalty mark.
- (d) at least 9.15 m (10 yds) away from the penalty mark.



Fig. 5.26: Penalty kick

Law 15

Throw-in: It is a method of restarting play. A throw-in is awarded to the opponents of the player who last touched the



ball when the whole of the ball crosses the touch line, either on the ground or in the air. A goal cannot be scored directly from a throw-in.

Law 16

Goal Kick: A goal kick is a method of restarting play. A goal kick is awarded when the whole of the ball passes over the goal line, either on the ground or in the air, having last touched a player of the attacking team. A goal may be scored directly from a goal kick, but only against the opposing team. If the goal kick is kicked into the team's own goal, a corner is awarded to the opposing team.

Law 17

Corner Kick: It is a method of restarting play. A corner kick is given when the whole of the ball passes over the goal line, either on the ground or in the air, having last touched a player of the defending team. A goal may be scored against the opposing team directly from a corner kick.

Measurements of playgrounds and specifications of equipment:

All lines in the playground must be of the same width and must not be more than 12 cm (5 inch).

Goal area: Two lines are drawn at right angles to the goal line, 5.5 m (6 yds) from inside of each goalpost. These lines extend into the field of play for a distance of 5.5 m (6 yds). These extended lines are joined by a line drawn parallel with the goal line. The area bounded by these lines and the goal line is the goal area. A goal kick is taken from the goal area only.

Penalty area

- Two lines are drawn at right angles to the goal line, 16.5 m (18 yds) from inside of each goalpost. These lines extend into the field of play for a distance of 16.5 m (18 yds). These extended lines are joined by a line drawn parallel with the goal line. The area bounded by these lines and the goal line is called the penalty area.
- Within each penalty area, a mark is made at a distance of 11 m (12 yds) from the midpoint between the goalposts or equidistant to them. This is called penalty mark.
- An arc with a radius of 9.15 m (10 yds) from the centre of each penalty mark is drawn outside the penalty area known as penalty arc.

Flag posts: A flag post, not less than 1.5 m (5 ft) high, with a non-pointed top and a flag must be placed at each corner. Flag posts may also be placed at each end of the halfway line, not less than 1 m (1 yd) outside the touch line.

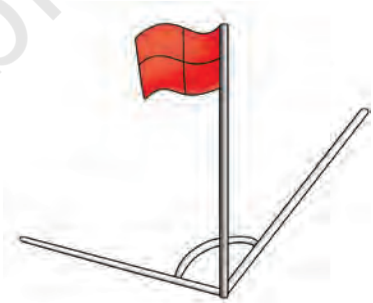
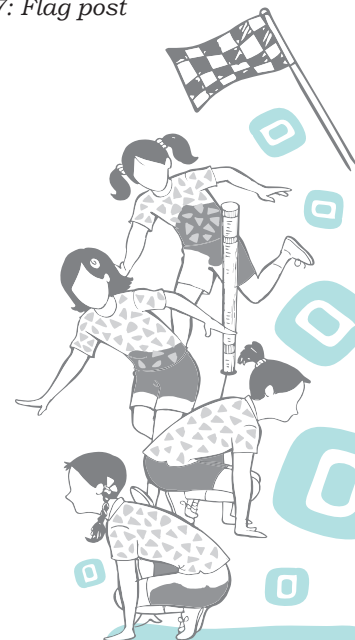

Fig. 5.27: Flag post



Goals: A goal must be placed on the centre of each goal line. A goal consists of two upright posts equidistant from the corner flag posts and joined at the top by a horizontal crossbar. The goalposts and crossbar must be made of wood, metal or other approved material.

They must be square, rectangular, round or elliptical in shape and must not be dangerous to players. The distance between the posts is 7.32 m (8 yds) and the distance from the lower edge of the crossbar to the ground is 2.44 m (8 ft).

Both goalposts and the crossbar have the same width and depth, which do not exceed 12 cm (5 inches). The goal lines must be of the same width as the goalposts and the crossbar. Nets may be attached to the goals and the ground behind the goal. These are properly supported and do not interfere with the goalkeeper. No part of the goalpost shall be projected towards or inside the playing area. The goalposts and crossbars must be white in colour.

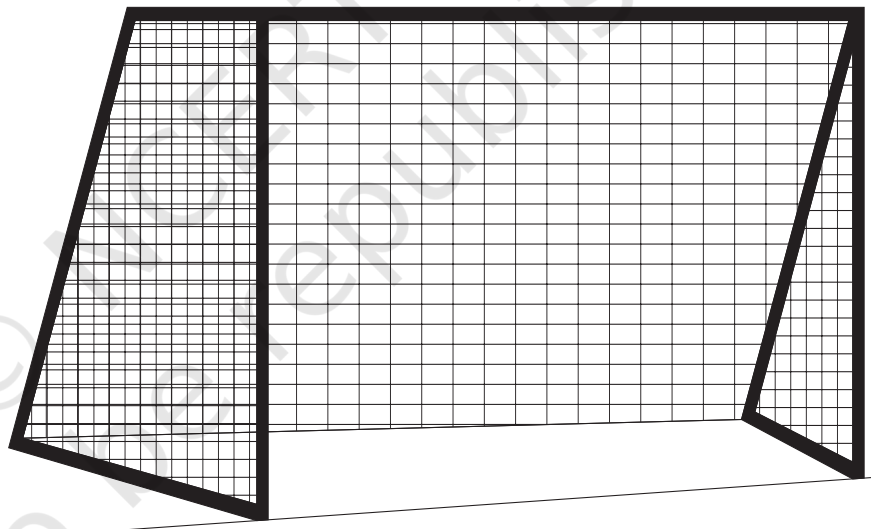

Fig. 5.28: Goalpost

Famous Indian Football Players

P.K. Banerjee, Chuni Goswami, Sunil Chhetri, I.M. Vijayan, Baichung Bhutia, V.P. Sathyan, Sandesh Jhingan, Sasmita Mallick, Aditi Chauhan, etc.

HANDBALL

History

At the end of the nineteenth century, somewhere in Northern Europe, it became necessary to unify the rules, which was

done by Karl Schelenz. The new game rules came in force in Berlin, in 1917. The sports international governing body was first formed in 1928 as the Federation International Handball Amateur. It took its current name in Copenhagen, Denmark in 1946 as the International Handball Federation (IHF). The first president of IHF was Avery Brundage—an American who went on to become president of the International Olympic Committee (IOC). The first Field Handball World Championships were played in Germany in 1938, following its appearance at the 1936 Berlin Olympic Games and then it made a comeback into the games in the 1972 Munich Olympic games. The women's version of the game was added in the 1976 Montreal Olympic games. Indoor Handball was invented in the 1940s in Denmark. The International Handball Federation which was established in 1946, oversees the game, and at present it has 175 member countries associated with it. The first International Handball Federation (IHF) World Men's Handball Championship commenced in 1954. The IHF World Women's Handball Championship commenced in 1957.

The Asian Handball Federation (AHF) is the governing body of handball in Asia. The Asian Handball Federation had begun when the Martyr Sheikh Fahad Al-Ahmad Al-Sabah of the Kuwait initiated a motion to the Executive Committee of the Asian Games requesting recognition of the handball game and also formation of the Asian Handball Federation during seventh Asian Games, Tehran, Iran in 1974. Accordingly, the Asian Games Federation during its meeting on 26th of August 1974, had recognised Handball as an official game. The headquarters is located in Kuwait City, Kuwait.

The Handball federation of India was established in 1972. The first senior National Handball Championship was held at Rohtak (Haryana) in 1972. Haryana won the gold medal and Vidharbha got the silver medal. First time in India, Handball Team participated in Asian Games held in India in 1982.

Functional Rules

Playing Area

The handball court measures 40 meters in length and 20 meters in width which is divided by the centre line. The goal area line, or 6-meter line, is the most important line. No one except the goalkeeper is allowed to stand in the goal area. Opponent players may not jump or enter into the goal area without releasing the ball for goal.

Do You Know?

In India, Handball was founded by Jagat Singh Chauhan who was Physical Education teacher and hailed from Haryana. He was the first secretary of Handball Federation of India.

Activity 5.9

Make a list of the famous handball players in male and female section.

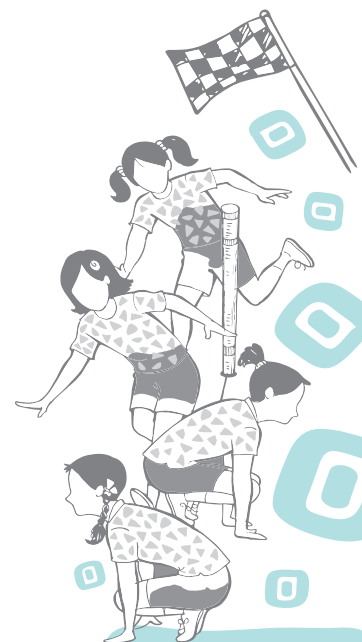

Handball Tournaments and Championships

World Championship, Olympic Games, Summer Olympics, Asian Olympics, Commonwealth Games are the tournaments organised by international sports organisations. Whereas, Handball Federation of India organises Federation Cup, National games and Indian Handball Super League, etc.

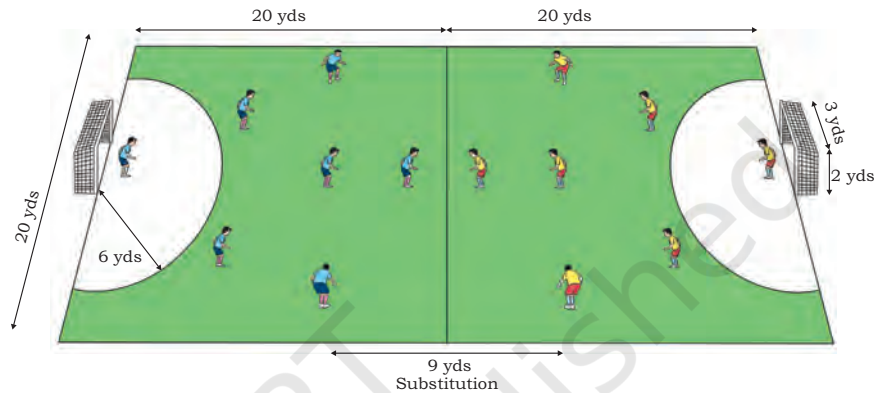

Fig. 5.29: Playing area and players, position in handball

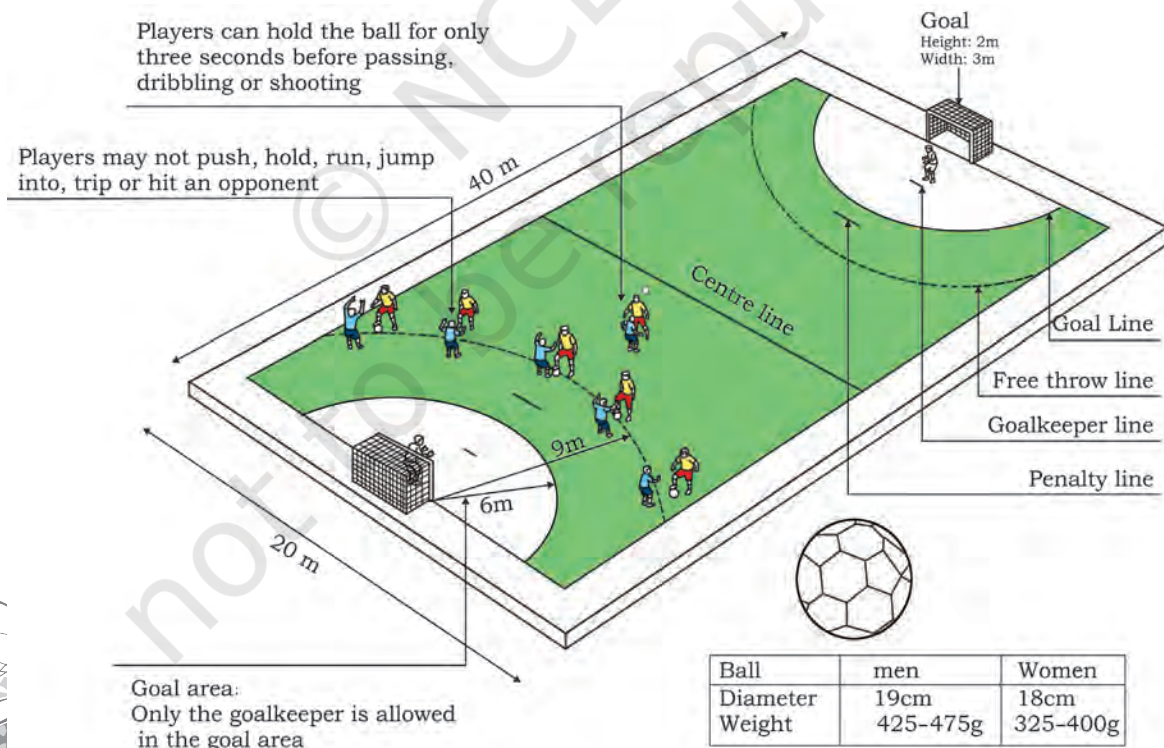

Fig. 5.30: Specifications and rules regarding handball

Number of Players

A team consists of 16 players and substitutes in each team. There are seven playing members on each team (six court players and one goalkeeper). Substitute team member may enter the game at any time repeatedly through the team's own substitution area as long as the player they are replacing has left the court. Player positions and nomenclature are given in the diagram.



Fig. 5.31: Players' attacking and defensive positions in handball court

Uniform of the Players

Player chest numbers range from 1 to 99. Uniform shirts and shorts are of the same colour. The goalkeeper must wear a different coloured shirt from the teammates and opponents. No jewellery is allowed.

Referees

There are two referees, a court referee and a goal line referee. Referees have complete authority and their decisions are final. The referees are assisted by a timekeeper and a scorer.

Duration of the Game

The duration of the match for different age groups is allotted as mentioned in the following table:

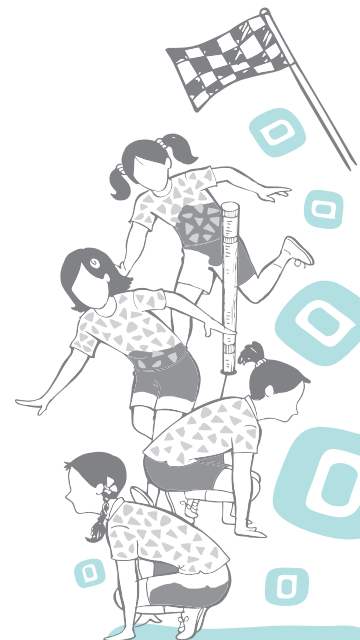

Table 4: Duration of the game

Age Group	Playing time with 10 minutes of interval
8–12 years	Two halves of 20 minutes
12–16 years	Two halves of 25 minutes
16 and above	Two halves of 30 minutes

This is running time except for injury or one team time-out. The teams have to change bench/side after half-time. Overtime consists of two halves of 5 minute/period with 1 minute half-time break. If the game is still tied, the winner will be determined in accordance with the rules of the particular competition.

Team Time-out

One minute time-out can be taken by each team in every half.

Throw-off

A throw-off is given to the team that wins the toss. Both the teams must be in their own side of the court with the defense 3 meters away from the ball. On a whistle, the ball is passed from centre court to a teammate and the play begins. Throw-off is repeated after every goal scored and after half-time.

Throw-in

When the ball goes out of bounds on the sideline or when the ball is last touched by a defensive player (not goalkeeper), a throw-in is awarded and goes out of bounds over the endline. The throw-in is taken from the nearest spot where the ball crossed out. The thrower must put either foot on the sideline to perform the throw-in. All opponents must stand 3 meters away from the ball.

Scoring

A goal is scored when the entire ball crosses the goal line inside the goal. A goal may be scored from any type of throw, i.e., free-throw, throw-in, throw-off, and goal-throw.

Playing the Ball

A player is permitted to throw, push, stop, catch, or hit the ball, by using hands (open or closed), head, arms, torso, thighs, and knees.

- (a) A player is allowed:
 - (i) to run with the ball for 3 steps.
 - (ii) to hold the ball for 3 seconds.



- (iii) unlimited dribble with 3 steps allowed before and after dribbling (no double-dribble).
- (iv) to take a maximum of 3 steps with the ball.

Defending the Opponent

A player may use the torso of the body to defend an opponent with or without the ball. However, using the outstretched arms or legs to obstruct, push, hold, trip or hit is not allowed. The attacking player is not allowed to charge into a defensive player.

Passive Play

A ball possession team cannot delay the game without making a recognisable attempt to attack and to shoot or goal. Referee Throw: A referee throw is awarded simultaneous infringement of the rules after simultaneous possession of the ball. The referee throws the ball vertically between two opposing players at centre court. The jumping players may tap the ball to a teammate or grab the ball. During this, other players must be 3 meters away from the ball.

Free-throw

Free-throw is awarded to the opponent against a minor foul or violation at the exact spot of the foul. If the foul or violation occurs between the goal area line and the 9 meter line, the throw is taken from the nearest post outside the 9 meter line. The thrower must keep one foot in contact with the floor.

A Player is NOT allowed to

- endanger an opponent with the ball.
- pull, hit or punch the ball out of the hands of an opponent.
- contact the ball below the knee.
- dive on the floor for a rolling or stationary ball.

7 Meter Throw

The 7 meter throw is awarded when:

- Illegally demolish a clear chance to goal
- The goalkeeper carries the ball back into his/her team's own goal area
- A court player intentionally plays the ball to his or her own goalkeeper in the goal area and the goalkeeper touches the ball
- A defensive player enters his or her goal area to gain an advantage over an attacking player in possession of the ball.

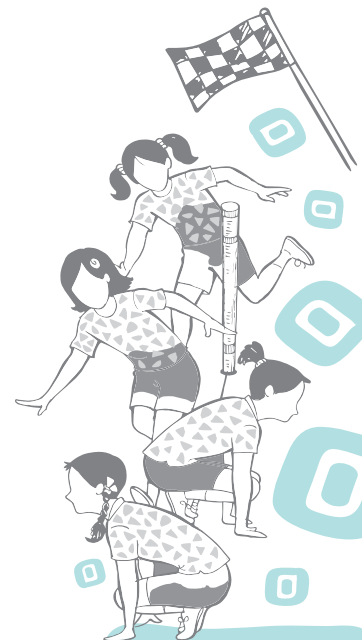

Activity 5.10

- Differentiate the yellow and red card penalties.
- What is the name of broken line as displayed in the figure?

- All players must be outside the free-throw line when the throw is taken. The player taking the throw has 3 seconds to shoot after referee's whistle.
- Any player may take the 7 meter throw.

Goal-throw

When the ball rebounds off the goalkeeper over the end line, a goal-throw is given. The player of the attacking team throws over the ball from the end line. The goalkeeper takes the throw inside the goal area and is not limited by the 3-step/3-second rule.

Progressive Punishments: These pertain to the fouls that require more punishment than just a free-throw. 'Actions' directed mainly at the opponent and not the ball (such as reaching around, holding, pushing, hitting, tripping and jumping into an opponent) are to be punished progressively.

Warnings (Yellow Card)

The referee gives only one warning to a player for rule violations and a total of three warnings to a team. Exceeding these limits results in 2 minute suspension thereafter. Warning is not required prior to giving 2 minute suspension. 2 minute suspension is awarded to a player for serious or repeated rule violations, like non-sportsmanship conduct, illegal substitution, etc.

Disqualification and Exclusion (Red Card)

A disqualification is equivalent to three 2 minute suspensions. A disqualified player must leave the competition arena. The team has to continue play for rest of the time with one player short due to player's disqualification.

Measurement of Playground and Specifications of Equipment**Playing Court**

The playing court in Handball is a 40 meter long and 20 meter wide rectangle, consisting of two goalposts. The longer boundary lines are called side lines, and the shorter ones are called goal lines (between the goalposts) or outer goal lines (on either side of the goal). There should be a safety zone surrounding the playing court, with a width of at least 1 meter along the side lines and 2 meters behind the goal lines.

- All lines on the court are fully part of the playing area that they enclose. The goal lines shall be 8 cm wide at the goalposts (see diagram), whereas all the other



lines shall be 5 cm wide. Lines between two adjacent areas may be replaced with a difference in colours between the adjacent areas of the floor.

- In front of each goal, there is a goal area. The goal area is defined by the goal area line (6 meter line), which is drawn with the following dimensions.
 - (a) A 3 meter long line directly in front of the goal; this line is parallel to the goal line and 6 metres away from it (measured from the rear edge of the goal line to the front edge of the goal area line).
 - (b) Two quarter circles, each with a radius of 6 metres (measured from the rear inner corner of the goalposts), connecting the 3 meter long line with the outer goal line.

The free throw line (9 metre line) is a broken line, drawn 3 metres outside the goal area line. Both the segments of the line and the spaces between them measure 15cm (see diagram).

The 7 meter line is a 1 meter long line, directly in front of the goal. It is parallel to the goal line and 7 meters away from it (measured from the rear edge of the goal line to the front edge of the 7 meter line) see diagram.

The goalkeeper's restraining line (the 4 meter line) is a 15cm long line, directly in front of the goal. It is parallel to the goal line and 4 metres away from it (measured from the rear edge of the goal line to the front edge of the 4 meter line). The center line connects the midpoints of the two side lines.

The substitution line (a segment of the side line) for each team extends from the center line to a point at a distance of 4.5 meters from the center line. This end point of the substitution line is enhanced by a line which is parallel to the center line, extending 15cm inside the side line and 15cm outside the side line (see diagrams).

Specifications of equipment

A goal (see diagrams) is placed in the center of each outer goal line. The goals must be firmly attached to the floor or the walls behind them. They have an interior height of 2 metres and a width of 3 metres.

The goalposts are joined by a horizontal crossbar. The rear side of the goalposts shall be in line with the rear edge of the goal line. The goalposts and the crossbar must have an 8cm square cross section. On the three sides which are visible from the court, they must be painted in bands of two contrasting colors, which also contrast clearly with the background. The goals must have a net, that should be attached in such a way that a ball thrown into the goal normally remains in the goal.

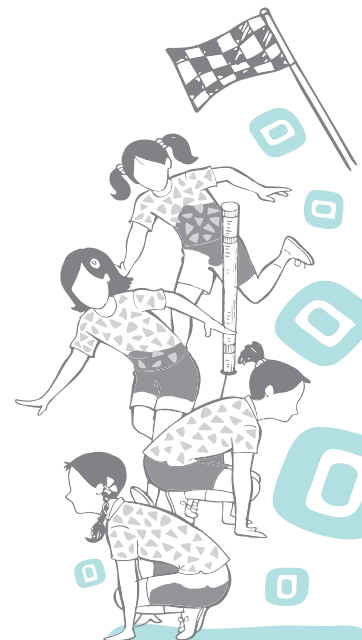

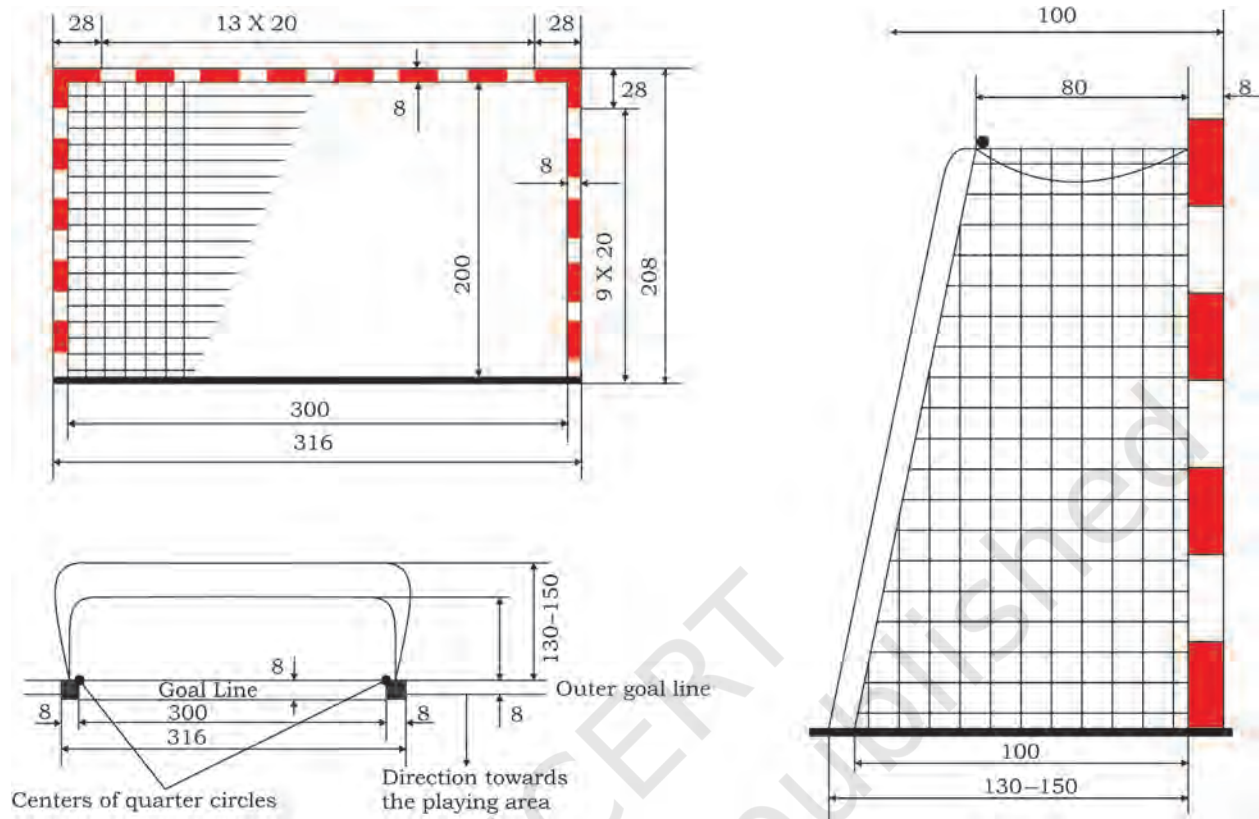

Fig. 5.32: Specifications of goalpost in handball (all dimensions indicated in cm)

Activity 5.11

What is substitution area and why is it used?

The Ball

Handball is played with a 32 panel leather ball. The ball sizes, to be used by different categories of teams are as follows:

Table 5: Ball Sizes According to Age Group

Ball Size	Age Group
58–60cm and 425–475g (IHF Size 3)	Men and Male youth of over age 16
54–56cm and 325–375g (IHF Size 2)	Women, Female youth (over age 14), and Male Youth (12–16 years)
50–52cm and 290–330g (IHF Size 1)	Female youth (8–14 years) and Male youth of age (8–12 years)

Table 6: Measurement Specifications

Terms	Units
Size of Playfield	40m × 20m
Shooting Circle	6m Goal Area Line and 9m free throw line/outer circle



Penalty Point	7m
Goalpost	2m × 3m
Ball	Weight: 425–475g (M), 325g–400g (W) Circumference: 58–60cm (M), 54cm–56cm (W)
No. of players	12 (7 court players and 5 substitutes)
Duration of game	2 Halves of 30 minutes (10 min break in each half)
Time Out in game	1 time out/half/team
Extra Time	2 halves of 5 minute each

Activity 5.12

- What is the air pressure of a handball?
- What is the size and weight of a handball?
- Who invented Handball?
- Which two countries played the first handball match in Olympic Games?

HOCKEY**History**

Historical records indicate that the crude form of hockey was played in Egypt around 4,000 years ago. Evidence also shows that a form of this game was played by Romans and Greeks. The modern game of hockey evolved in England in the mid-eighteenth century, primarily around the schools.

The first Olympic Hockey Competition for men was held in London in 1908. Ireland and Scotland competed separately. After having made its first appearance in 1908 games, hockey was subsequently dropped from the 1912 Stockholm Olympic Games. It reappeared in 1920 at Antwerp (Belgium) before being omitted again in Paris in 1924. The Paris organisers refused to include hockey in the Olympics, stating that the sport had no International Federation.

Hockey had made its first step towards an International Federation in 1909 when the Hockey Association in England and the Belgium Hockey Association agreed to recognise each other to regulate international hockey relations. The French Association followed soon after, but this was not considered sufficient to recognise this game at the international level.

Federation International de Hockey (FIH)

The International Hockey Federation, the world governing body was founded in Paris in 1924, initiated by Paul Leautey, a Frenchman. Paul Leautey became the first President of the FIH.

In many ways, the FIH serves as the ‘guardian’ of the sport. It works in co-operation with both the national and

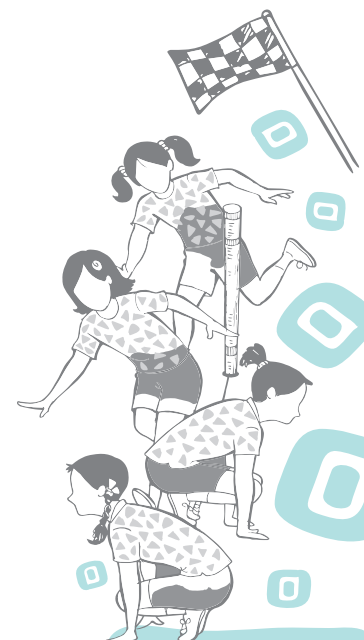

continental organisations to ensure consistency and unity in hockey around the world.

The Federation International Hockey (FIH) not only regulates the sport, but is also responsible for its development and promotion so as to guarantee a secure future for hockey.

FIH comprises a network of five continental federations (CHFS), 12 National associations (NHAS), an executive board and 7 expert advisory committees, with a Head Office in Brussels. The FIH retains overall responsibility for hockey worldwide, including the rules of hockey, umpiring and coaching.

Measurement of Playground and Specifications of Equipment

Field and field equipment

The field of play is rectangular, 91.40 metres long, bounded by sidelines and 55 metres wide, bounded by backlines.

1. Markings

- (a) The lines are 75 mm wide and must be clearly marked along their entire length.
- (b) All the marks must be made in white.

2. Lines and other marks

- (a) Side-lines: 91.40 metres long perimeter lines
- (b) Back-lines: 55.00 metres long perimeter lines
- (c) Goal-lines: the parts of the back-lines between the goal-posts
- (d) Centre-line: across the middle of the field
- (e) 22.90 metre lines across the field 22.90 metres from each backline as measured between the furthest edges of each line.
- (f) 300 mm long lines marked outside the field on each sideline with the further edge of the lines 14.63 metres from and parallel to the outer edge of the backlines.
- (g) 300 mm long lines marked outside the field on each backline on both sides of the goal at 5 metres.
- (h) 10 metres from the outer edge of the nearer goalpost, as measured between the furthest edges of each line.

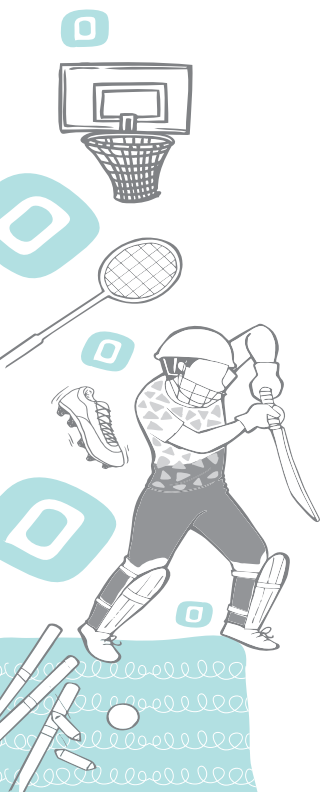

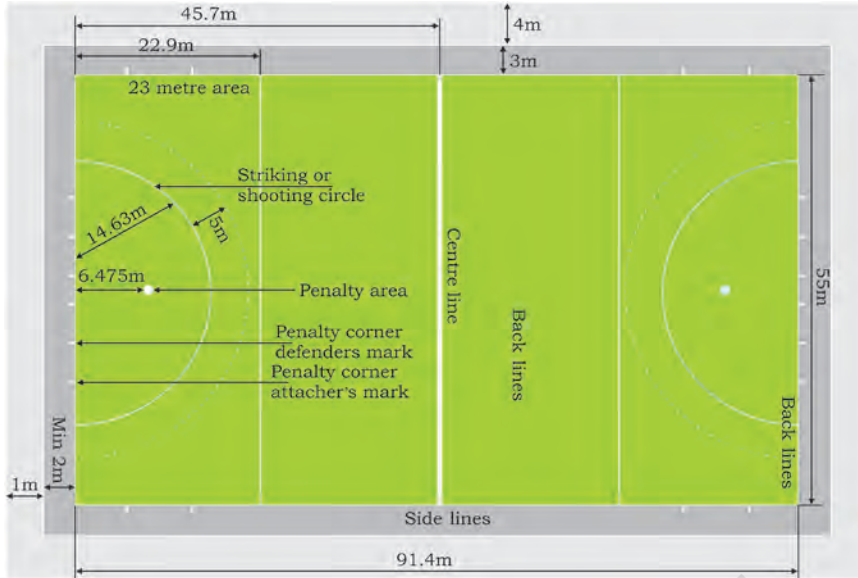

Fig. 5.33: Hockey playground

3. Goals

- Two vertical goalposts joined by a horizontal crossbar are placed at the centre of each backline on the external marks.
- The goalposts and crossbar are white, rectangular in cross section, 50 mm wide and between 50 mm to 75 mm deep.
- The goal posts must not extend vertically beyond the crossbar and the crossbar must not extend horizontally beyond the goalposts.
- The distance between the inner edges of the goalposts is 3.66 metres and the distance from the lower edge of the crossbar to the ground is 2.14 metres.
- The space outside the field, behind the goalposts should be enclosed by the net, side-boards and backboard is a minimum of 0.90 metres deep at the crossbar and a minimum of 1.20 metres deep at ground-level.

4. Sideboards and backboards

- Sideboards are 460 mm high and a minimum of 1.20 metres long.
- Backboards are 460 mm high and 3.66 metres long.
- Sideboards are positioned on the ground at right angles to the back line and are fixed to the back of the goalposts without increasing their width.

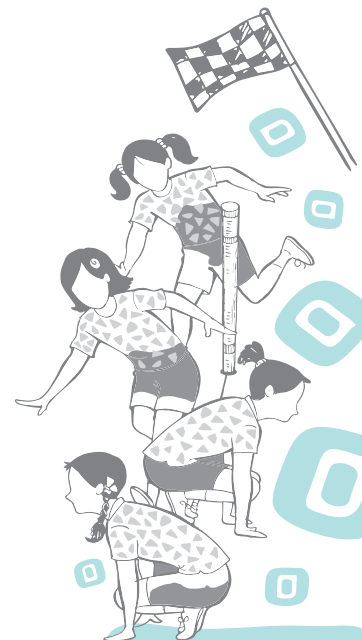

- (d) Backboards are positioned on the ground at right angles to the side boards and parallel to the backline, and are fixed to the end of the sideboards.
- (e) Sideboards and backboards are of dark colour on the inside.

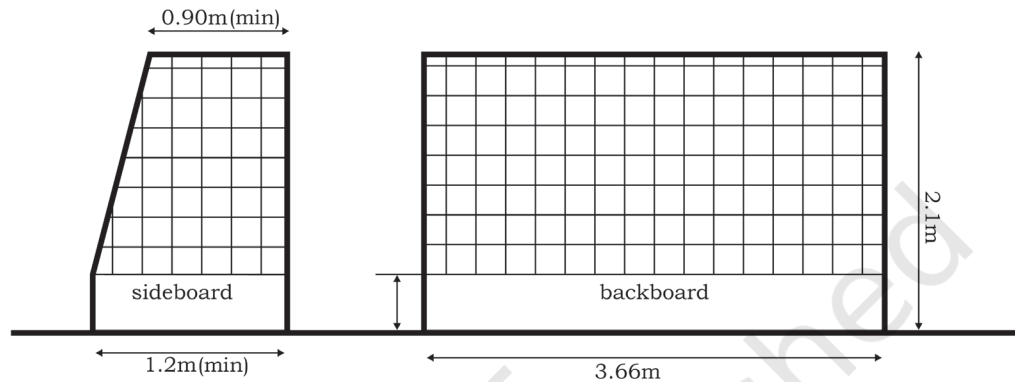

Fig. 5.34: Specifications of net

5. Nets

- (a) The maximum mesh size is 45 mm.
- (b) Attachment to the back of the goalposts and crossbar is at intervals of not more than 150 mm.
- (c) The nets are hung outside the sideboards and backboard.
- (d) The nets are secured so as to prevent the ball from passing between the net and the goalposts, cross bar, sideboards and back-boards.
- (e) The nets are fitted loosely to prevent the ball from rebounding.

6. Flagposts

- (a) Flagposts are between 1.20 and 1.50 metres in height.
- (b) Flagposts are placed at each corner of the field.
- (c) Flagposts must not be dangerous.
- (d) If unbreakable, flagposts must be attached to a spring base.
- (e) Flagposts carry flags, not exceeding 300 mm in width or length.

7. Stick

- (a) The head must be a 'J' or 'U' shape.
- (b) The head must be flat on the left hand side only.



- (c) Any curvature along the length of the stick (the bow or rake) must have a continuous smooth profile along the whole length, and must occur along the playing side or the back of the stick but not both and is limited to a depth of 25 mm.

8. Ball

- (a) is spherical.
- (b) has a circumference between 224 mm and 235 mm.
- (c) weighs between 156 grams and 163 grams.
- (d) is made of any material and coloured white (or an agreed colour which contrasts with the playing surface).
- (e) is hard with a smooth surface but indentations are permitted.

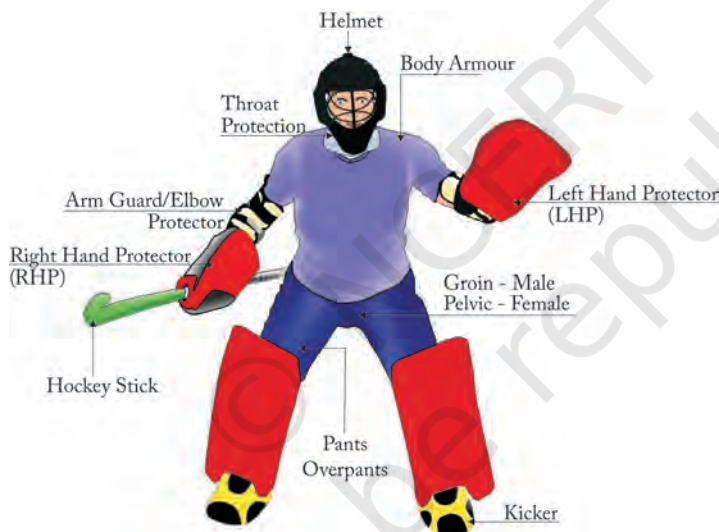

Fig. 5.35: Goalkeepers equipment

Goalkeeper's equipment

1. Hand protectors

- (a) each has a maximum width of 228 mm and length of 355 mm when laid flat, with palm upwards
- (b) must not have any addition to retain the stick when the stick is not held in the hand.

2. Leg guards

- (a) each has a maximum width of 300 mm when worn on the leg of the goalkeeper.
- (b) The dimensions of the goalkeeper's hand protectors and leg guards are measured using gauges with the relevant internal dimensions.

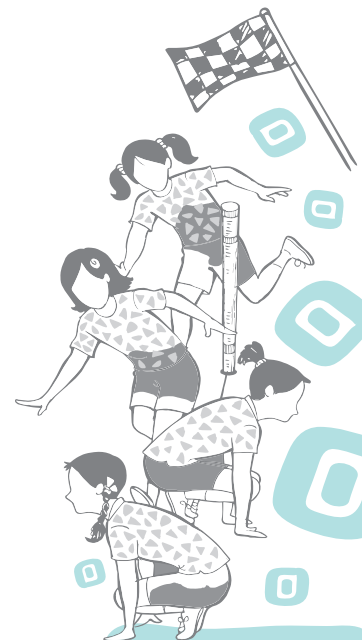

Do You Know?

In Hockey, rolling substitution is allowed and any number of times a player can be substituted.

Functional rules of Hockey

The rules of the hockey game are developed and modified time to time only by International Hockey Federation to add glamour and excitement in the match. These rules can be understood as given below.

Teams

Each team consists of 16 players, out of which 11 players play on the field at a time, which includes ten regular players and one goal keeper. Five substitution players remain on the sideline. In rare circumstances, a team will choose to pull its goal keeper off the field in exchange for an extra field player. The players on the sideline can be used as substitutes for any of the players on the field at any given time.

Coin Toss

Before the start of the match, the umpire tosses a coin. The home team gets to choose whether it wants heads or tails. The team that wins the toss gets its choice of either possession of the ball at the start or the side of the field to defend.

Positions

Positions in field hockey are not absolute. Generally, teams arrange players for defence, midfield, and attack. Many teams include a single player as the last defender called sweeper. Sweeper acts as a last line of defense in front of the goal keeper. The minimum number of players needed for a game is nine, including the goal keeper.

Goal Keeper

Goal keeper is the last defender of a team and shall have distinguished jersey colour than that of teammates. A full protected goal keeper cannot leave the side's defensive 25 yards (23m) line during play, unless the goal keeper is defending a penalty stroke.

The player who is substituted as a goalkeeper must wear a helmet, a thigh pad and sometimes a shoe protector. If the team wants an additional player in the place of a goal keeper, then the goalkeeper designated player must wear different coloured jersey and cannot use their feet or hands outside the 23 meter mark.

Handling Hockey Stick

The head part of a hockey stick is hooked. The right-hand side of the stick is rounded, while the left-hand side is flat. The ball can be played only with the flat, left-handed side



of the stick, or with its edge. The ball cannot be played with the rounded side of stick. This is natural for right-handed players and unnatural for left-handed players. Left-handed sticks are not allowed to be used in games.

Hitting the Ball

To make a legal hit to the right without using the rounding side of the stick, a player must turn the stick over the ball and use the flat side. Taking a hit by reversing the stick head, turning the handle approximately 180 degrees over the ball and striking the ball with a left-to-right swing with the flat side of the stick is called reverse hit.

Dribbling

Keeping the ball under close control is called dribbling. Dribbling is used while running with possession of the ball. It helps a player to move away from the opposing players for a chance to pass or to hit on goal. Other essential skills for playing field hockey are the ability to control, pass, push, stop, and shoot the ball with the stick.

Foot Foul

Field Hockey players are not allowed to use their feet, or any other body part, to control the ball. If the ball hits a player's foot, the umpire will either award the other team a free hit or let the game continue if the other team gains an advantage. Only the goalkeeper is allowed to use hands, feet, and body to stop or strike the ball.

Air Ball

The ball is allowed to be lifted in the air as long as the referee does not consider the play to be 'dangerous.' The umpire will make a call if the ball could potentially hit or injure another player. The general rule is that the ball should not be lifted above the knee within five meters of another player. An exception to this rule is when the ball is raised by using a scooping or long-pushing action of the stick, or when there are no players in the same proximity as the ball. The ball cannot be hit into the air unless it is a direct shot on goal.

Scoring

There are three different ways to score a goal in field hockey.

- 1. Field goal:** A goal can only be scored if the shot is taken within the 'shooting circle', a semi-circular area in front of the opponent's goal. The shooting circle is also known as the 'D' for the defensive team. The ball must be touched by a player of either team inside the circle for it to count as a goal.

Activity 5.13

Collect information about the world governing body for hockey.

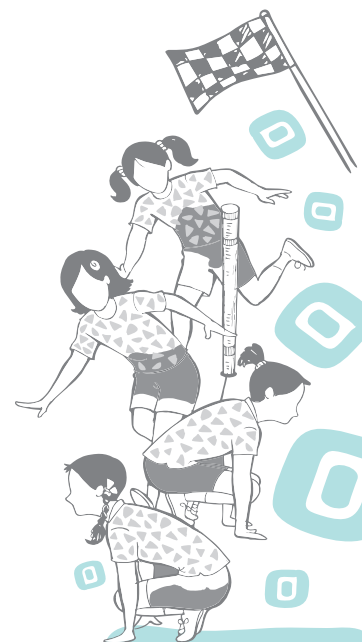

2. Penalty Corner: A penalty corner is awarded when the defensive team breaks certain rules inside the 'D', or when a defender commits an intentional offense outside the circle but within the 25 yards (23 metres) area. Teams generally have a set play for short corner. A short corner is the best opportunity to score a goal in field hockey, because the offensive team attacks with more number of players than the defensive team.

The following procedure should be applied to execute a penalty corner during the match.

- Play is stopped for a penalty corner to allow time for both teams to set up its respective attack and defense positions.
- Defensive team is allowed to put five defenders including the goal keeper on the end line.
- The rest of the defensive team must stay behind the center line until the ball is pushed out by the offensive player.
- One of the attackers will stand on the end line 11 yards (10 meters) away from the goal called 'pusher', and who pushes the ball out to the attackers on top of the shooting circle.
- The ball is stopped by one of the waiting attacking team players called 'stopper', standing on the 16 yards circle. The stopper will stop the ball for the team mate to either hit or to drag the ball into goal.
- In order to count a goal during a penalty corner, the ball must travel outside the shooting circle before hitting the ball into the goal. The receiver will then push the ball back into the circle for a shot to be taken. The shot has to be taken from inside the marked circle for the goal to count.
- Fouls during penalty corner
 - If the first shot into the goal during penalty corner is a hard hit and the ball is lifted in the air above the backboard, the goal will not be counted.
 - To avoid the foul during penalty corner, the attacker must take push or scoop or flick shots in the goal. Even if the ball is lifted in the air due to push or scoop or flick shots, a goal is scored. On the international level, the 'drag flick' is the most popular type of lifted shot during the penalty corner.

3. Penalty Stroke: A penalty stroke is a single shot taken on goal by an offensive player chosen by the team. The goalkeeper is the only opposing player that can defend this shot. A stroke may be awarded for a number of reasons. The most common reason for a stroke to be taken is when a defender commits a foul that directly prevents a goal from being scored.



The shot is taken from a spot referred to as the penalty stroke mark. It is located 7 yards (6.4 meters) directly in front and center of the goal. Game play is stopped during the penalty stroke and all players must stand away and outside of 25 yards (23 metres) line. The player taking penalty stroke must push, flick or scoop the ball towards the goal and is permitted to raise the ball to any height.

Fouls during penalty Stroke: When the stick makes contact with the ball, it should make no distinct hitting noise; otherwise the umpire can disallow the penalty stroke.

Free Hits

Free hits are awarded throughout the main part of the field for general offences by either team. The most common fouls that lead to free hits are:

- Obstructing an opponent from playing the ball.
- Interfering with the stick or body when tackling.
- Kicking the ball with leg.
- Playing the ball dangerously (including lifting the ball).

Procedure to take a free hit

- In a free hit, the ball possession is given to the opponent team where the offence took place.
- The ball is placed on the ground and a player will restart the action by passing it to a teammate, hitting the ball forward or backward, or through a self-pass (either by dribbling the ball or hitting it into space). All the opposing players must stand at least 5 yards from this player until the ball is put into play.
- If the ball is within the 25 yards area of a goal, the ball cannot be directly hit into the circle. The ball must travel 5 yards by dribbling or passing before it can be hit into the circle and shot at the goal.

Obstruction

In most general terms, obstruction is called when the ball is shielded from an opposing player who is trying to get the ball. Players often use their own bodies or sticks to block the ball, but third party obstruction can also be called. Third party obstruction is called when an attacking player runs to block an opponent's path (who is trying to get the ball) between a teammate who has possession of the ball.

Match Time

An international match time is 60 minutes with four 15-minute quarter (first quarter 15m and 2m for rest, second quarter 15m and 10m for rest third quarter 15m and 2m for rest and fourth quarter 15m) for rest. The additional time out for

Activity 5.14

Collect the names of players who have received Arjuna Award in the last two years.

Do You Know?

The National Championship in Hockey is known as Rangaswamy Cup.

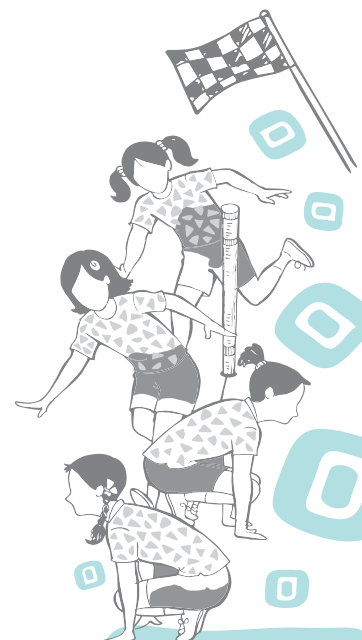

Do You Know?

The Indian Men's Hockey team remained unbeaten in the Olympics, winning six gold medals in a row. The Indian team has won a total of eight gold medals till date.

penalty corners and after goals ensure that the new 60 minutes format is primarily the actual playing time and eliminates the dead time associated with penalty corner set up while allowing the teams to enjoy their goal celebration.

Penalty Shootout

The team that scores the most goals within the match time is the winner. According to the International Hockey Federation, if no goals are scored during regulation time, the game will end in a tie or draw. In the Knock Out Tournament, the winner is decided on the basis of penalty shootout.

The New Match Time Format

- Match duration: 60 minutes equally divided in four quarters
- 40 seconds time out: After penalty corner awarded and after a goal scored
- Two minutes break after the first and the third quarters and 10 minutes break for half time.

The penalty shootout will be taken under the following conditions—

1. The defending goalkeeper will stand behind his own goal line, between the goal post.
2. The ball is placed on the nearest 23 m line in a position opposite the center of the goal.
3. The umpire blows his whistle to signal the start of the shootout. The attacker and the goalkeeper may then move in any direction.
4. An attacker will start from behind the 23 m line near the ball.
5. The shootout is completed when any one of the following occur—
 - (a) 8 seconds has elapsed
 - (b) The attacker scores a goal
 - (c) The attacker commits an offence
 - (d) The goalkeeper commits an offence a goal shall be awarded
 - (e) The ball goes out-of-play over the back line, this include the goalkeeper who may intentionally play the ball over the back line to end the shootout.

Umpires

There are two umpires (or 'referees') in each game. Each umpire controls half of the field, although general play in the midfield can be called by either umpire.



An umpire can give a card to any player who has committed a repeated offence. There are three types of cards:

Green card: Temporarily suspends the player for a minimum of two minutes of playing time.

Yellow card: Temporarily suspends the player for a minimum of five minutes of playing time.

Red card: Permanently suspends the player from the match.

If a player is suspended temporarily or permanently, then the team plays with the remaining players.

Umpire Calls

The whistle is the umpire's tool to enforce the rules of the game. The umpire blows the whistle to:

- start the first and second half of the game
- start a bully
- call a foul
- start and end a penalty stroke
- indicate a goal
- restart a match after it has been stopped
- stop a match to substitute players into the game
- stop the match for an injury

The umpire uses the whistle to keep the game moving smoothly. The umpire will also use hand signals to indicate the specifics of the call.

Outstanding Hockey Players: Some of the outstanding hockey players in India are Prithpal, Ajit Pal Singh, M.P. Ganesh, Roopa Saini, Vasudeven Bhaskaran, Zafar Iqbal, Pargat Singh, Jagbir Singh, Dhanraj Pillai, Rajendra Singh, Dilip Trikey, Mamta Kharab, Deepak Thakur, Sandeep Singh, Ritu Rani, Sardar Singh, etc.

KABADDI

History

Kabaddi is an indigenous game of India which has originated and developed since the epic age of Mahabharata. The word 'Kabaddi' has been derived from the term *Kaunbada* which means 'to challenge an opponent'. The game, known as *Hu-Tu-Tu* in Western India, *Ha-Do-Do* in Eastern India and Bangladesh, *Chedugudu* in Southern India and *Kaunbada* in Northern India. Kabaddi attained national status in the year 1918. Maharashtra was the pioneer state to bring the game to the national platform and popularity. Standard rules and regulations were formulated in 1918 but were brought out in print in the year 1923 and in this very year, an All India Tournament was organised at Baroda with these rules.

Activity 5.15

Collect information on the years in which Indian Men's Hockey team won Olympic gold medals.

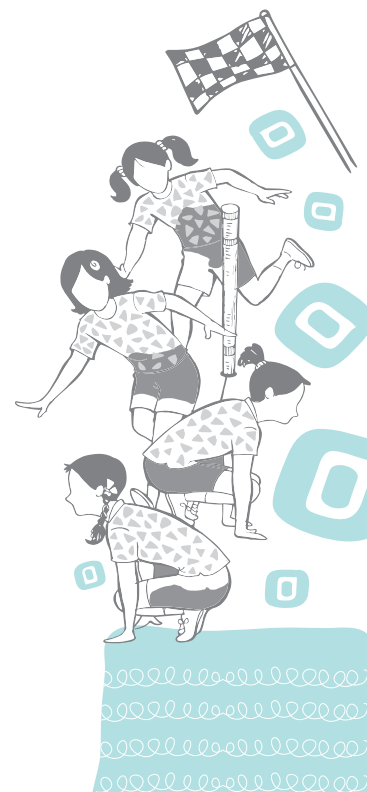

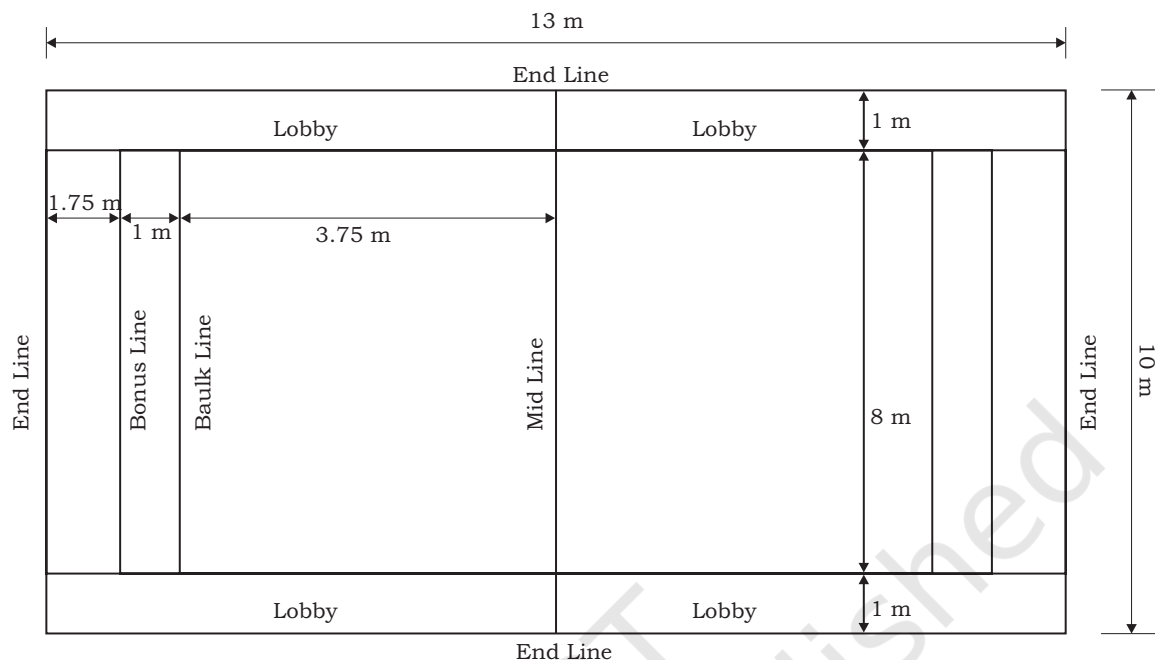

Fig. 5.36: Specifications of net

Table 7: Measurement of Kabaddi Ground**Do You Know?**

Kabaddi received international exposure during the 1936 Berlin Olympics, demonstrated by Hanuman Vyayam Prasarak Mandal, Amaravati, Maharashtra.

Size of Kabaddi Court	13 × 10 m (for men) 11 × 08 m (for boys and women)
Size of Lobby	1 m wide on both sides
Distance of Baulk Line from Mid-Line	3.75 m
Distance of Bonus Line from Mid-Line	4.75 m

Modern Kabaddi is a synthesis of the game which is played in various forms under different names. The game was introduced in the Indian Olympic Games at Calcutta in 1938. In 1950, the All India Kabaddi Federation came into existence and compiled standard rules.

The Amateur Kabaddi Federation of India (AKFI) was founded in 1973. After the formation of Amateur Kabaddi Federation of India, the first men's nationals were held in Madras (renamed as Chennai), while the women's nationals were held in Calcutta (renamed as Kolkata) in 1955 (1955 does not come after 1973). The AKFI has given shape to the new rules and has the right to modify them. The Asian Kabaddi Federation was founded under the chairmanship of Janardan Singh Gehlot.

Rules of Kabaddi

Team

Each team shall consist of minimum 10 and maximum 12 Players. Seven players shall play at a time and the remaining players are substitutes.

Duration of the match

The duration of the match shall be of two halves, i.e., 20 minutes of each half. In case of men and junior boys there is an interval of 5 minutes. In the case of women, junior girls, sub-junior boys and girls, there are two halves of 15 minutes with 5 minutes interval. The side that wins the toss shall have the choice of the court or the raid. The teams shall change the court after first interval. The number of players for each team at the start of second half shall remain the same as it was at the end of first half. The last raid of each half of the match shall be allowed to be completed even after completion of the scheduled time as mentioned above.

Rules for Raider

- Raider shall continue to chant “Kabaddi”. Raider must start the chant before the player touches the opponent’s court.
- If a raider goes out of turn, the Umpire or Referee shall order the raider to go back and a technical point will be given to the opponent team.
- Not more than one raider shall enter the opponent’s court at a time; otherwise a technical point will be awarded to the opponent and a chance to raid.
- When a raider is out the raid is over, the opponent should send their raider within 5 seconds. Otherwise their team loses its turn of raiding.
- If a raider, who is caught by the catcher, escapes from their attempt to hold and reaches his court safely, he shall not be pursued further.
- When a raid is held, the catcher shall not try deliberately stifle the raiders chant by shutting his mouth, using violent tackling leading to injuries, any type of scissoring or any unfair means. If such incident happens, the Umpire or Referee shall declare the raider ‘Not Out’.

Rules and regulations

- No catcher shall willfully push the raider out of the boundary by any part of his body, nor shall any raider willfully push or pull catcher’s body out of the boundary. If the raider is pushed outside the boundary or the

Do You Know?

Kabaddi is now played indoor on mats after wearing mat shoes.

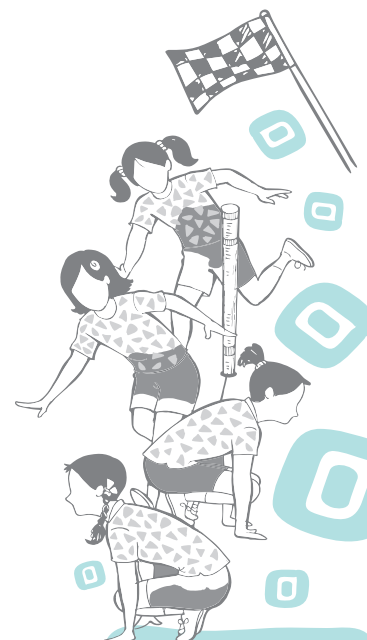

Do You Know?

After all the members of a team are declared out, the opponent team will be awarded two extra points known as 'Lona'.

catcher is pushed or pulled outside the boundary, the Umpire or Referee shall declare the raider or the catcher, as the case may be, as 'Not Out', and the catcher or the raider who pushes or pulls the opponents outside the boundary shall be declared out.

- During the course of raid, none of the catcher shall touch the raider's court until completion of the raid. In case any catcher touches the raider's court before completion of the raid, they will be declared out and the opponent team will be given that many points.
- When a team manages to put out the entire opponent team and none of the opponents are entitled to be revived, then that team scores a lona and two extra points for lona shall be awarded in addition to the points scored by the team putting out all the players of the opponent. The play continues and all the players who are out shall enter in their court within 10 seconds. Otherwise the referee or umpire shall award one technical point to the opponent. If the team fails to enter within one minute, the team shall be scratched from the match and the match shall be awarded to the opponent.
- If a raider is warned or in any way instructed by one player of his own side, the Umpire or Referee shall award one technical point to the opponent.
- A raider or catcher is not to be held by any part of his cloth deliberately other than his limb or trunk. The one who violates the rule shall be declared out. If the raider is held deliberately other than his limb or trunk, the Umpire or Referee shall declare such raider as not out.

Note: If a raider is intentionally caught by clothes or hair, the raider shall be declared 'not out' and the catcher who has violated the rule shall be declared out.

- When one or two players of a team are left during the game and the Captain of the team declares them out in order to bring in the full team, the opponent shall score as many points as the players that existed in the court at the time of declaration as well as two extra points for 'lona'.
- A player or players who are out shall be revived in the same order as they were out when one or more opponents are out.

System of Scoring

Each team shall score one point for every opponent out or put out. The side, which scores a 'lona', shall score two extra points.



Time Out

Each team shall be allowed to take two 'Time Outs' of 30 seconds each in each half; such 'time out' shall be called for by the Captain, Coach or any playing member of the team with the permission of referee. The 'time out' time shall be added to the match time.

Substitution

Five reserve players can be substituted with the permission of the Referee during 'time out' or interval.

Bonus Point

For crossing the bonus line, when catcher team have minimum six players, bonus point is awarded to the raider.

Result

The team, which scores the highest number of points at the end of the match, shall be declared the winner.

Tie in Knockout

If there is a tie in the Knockout match, the match will be played of 5-5 raids where both the teams should field 7 players in the Court and baulk line is treated as bonus line but point remains the same. Listed players will perform the raid alternatively; no one will be out, only score points will be given to their respective team. At last the team which scored more points is declared the winner.

Golden Raid

- Even after 5–5 raids, if there is a tie, a fresh toss will be taken and the team that wins the toss shall have the chance to raid, i.e., 'Golden Raid'.
- If there is a tie even after the Golden Raid, then a chance will be given to the opponent team for the Golden Raid.
- In the Golden Raid, the team which scores the leading point shall be declared as winner.

Green Card is flashed for warning, Yellow Card for temporary suspension for 2 minutes, and Red Card for suspension from the match or to debar from the tournament.

Fundamental skills in Kabaddi

The main objective of the defence players or catcher is to catch the raider and prevent him from escaping to his home court. To achieve this objective, the catcher can use any of the six fundamental defence skills, i.e., ankle hold, thigh hold, knee hold, waist hold, wrist hold and arm hold.

Activity 5.16

Ask your teacher to conduct inter house Kabaddi Matches in your school.

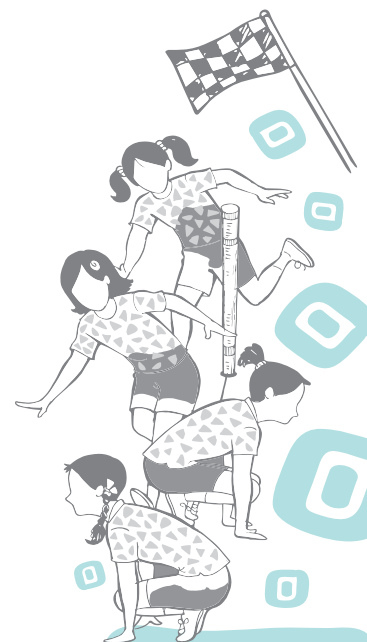

Activity 5.17

- Is there a weight categorisation for Kabaddi?
- Find out the age and weight categories of Kabaddi in SGFI.

Ankle hold

Ankle hold is one of the commonly used defensive skills. In this technique, the defending player (catcher) holds the ankle of the raider with both hands.



Fig. 5.37: Ankle hold

Thigh hold

It is also a defensive technique in which the defender throws his body on the raider to hold both thighs with the arms around the thighs of raider.



Fig. 5.38: Thigh hold



Knee hold

This is not a common skill in kabaddi but when used by the defender, it works like a jaw to catch the raider.



Fig. 5.39: Knee hold

Waist hold

Waist hold is used during the struggle when the raider moves back to one's own court after the raid.



Fig. 5.40: Waist hold

Wrist hold

Wrist holding technique is best used during one to one situation and not advised during the usual course of game.

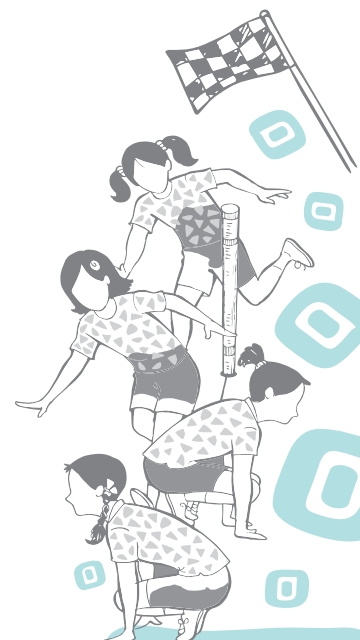



Fig. 5.41: Wrist hold

Arm hold

During struggle, arms of the raider are held to stabilise the raider but this is not a very common practice as the arm hold is natural action occurs during competition.



Fig. 5.42: Arm hold



Offensive skills

Toe touch

Toe touch is executed by the raider to touch the opponent by toe during raid for scoring a point.



Fig. 5.43: Toe touch

Side kick

The raider tries to touch the opponent by side kicking, keeping in mind that the opponent should not hold the leg.

Front kick

In front kick, the raider tries to kick from front, in a deceiving action, keeping in mind that the opponent should not grab the leg.



Fig. 5.44: Front kick

Mule or Back kick

It is a deceiving kick, performed by standing in front of the opponent and facing in the same direction.

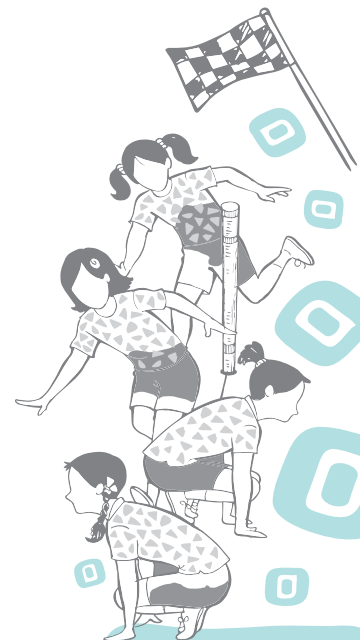

Activity 5.18

- How many gold medals did India win in Asian games, Jakarta-Palembang (Indonesia) 2018?
- Collect the information of teams and their occupied owners in Professional Kabaddi League in India.

Do You Know?

- India is the first country to introduce Professional Kabaddi League.
- Asian Kabaddi circuit is dominated by Indian coaches and players to develop the game of Kabaddi in Asia.



Fig. 5.45: Mule or back kick

Awards in Kabaddi

To motivate the extraordinary achievements of the players and Coaches, the Government of India honours players with different awards along with cash prizes and certificates.

In the year 2018, G. Pranav Sai Reddy of received Arjuna Award. E. Prasad Rao has been awarded with Dronacharya Award for an excellent contribution as a Coach.

KHO-KHO

The game Kho-Kho is based upon the natural principles of physical development and develops all of the motor qualities of an individual. It involves and cultivates a healthy combative spirit among the youth. It is not merely a game of running with speed but also to chase at natural instinct to overtake.

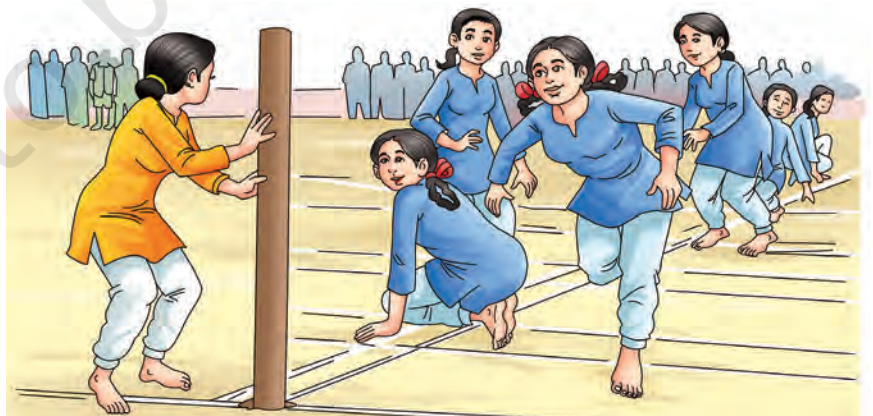

Fig. 5.46: Players in kho-kho playground



History of Kho-Kho

The origin of Kho-Kho is not easy to mark out, but many historians believe that it is a modified form of 'Run and Chase', which in its simplest form involves chasing and touching a person. The popularity and development of this game has been associated with the development of 'Akharas' and 'Vyayamshalas' in Maharashtra. Probably, the game Kho-Kho has originated from Pune, Maharashtra and slowly spread within the country and also gained popularity in the neighbouring countries, i.e., Nepal, Bangladesh, Sri Lanka and Pakistan. The rules of this game were framed in 1914 by a committee of veteran players. Initially two players were made to stand at the two ends instead of the posts. The game is controlled and governed by the rules formed by Kho-Kho Federation of India which was established in 1956. It is believed that the first championship of Kho-Kho was held in 1959 at Vijaywada. 'Hanuman Vyayam Prasarak Mandal' Amravati, has given the modern form to this game. Kho-Kho game was first introduced in the National Games in 1985, held in Delhi. First Asian Kho-Kho championship was held in 1996 in Calcutta, where Nepal, Bangladesh, Sri Lanka and India participated. It was also introduced as a demonstration game in the Berlin Olympics in 1936.

Do You Know?

Practice of Kho-Kho helps to develop coordinative abilities more than other games.

Measurements of Kho-Kho Playground

Kho-Kho ground is rectangular in shape and can be constructed either outdoor or indoor. In outdoor spaces, it should be made on a levelled clay surface and synthetic or wooden surface should be used when playing indoors.

Table 8: Basics of Kho-Kho

Terms	Units
Shape of the playfield	Rectangular
Total area including lobbies	32m × 21m
Dimensions of the playfield	27m × 16m (Men/Women and Junior Boys/Girls) 23m × 14m (Sub Junior Boys/Girls)
Free Zone	1.5m × 16m (Men/Women and Junior Boys/Girls) 1.5m × 14m (Sub Junior Boys/Girls)
Centre Lane	24m (Men/Women and Junior Boys/Girls) 20m (Sub Junior Boys/Girls)

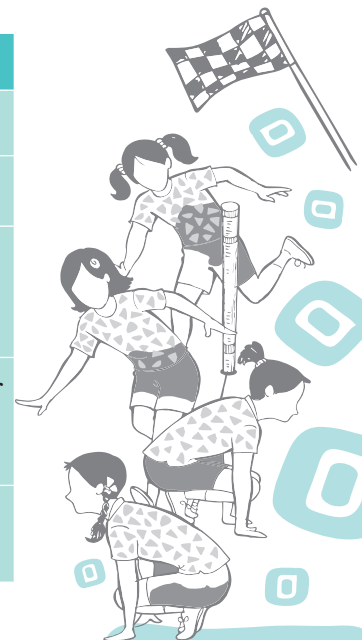

Terms	Units
Cross Lane	35cm × 30cm (Men/Women and Junior Boys/Girls) 30cm × 30cm (Sub Junior Boys/Girls)
Distance: Pole to first Cross lane	2.55m (Men/Women and Junior Boys/Girls) 2.15m (Sub Junior Boys/Girls)
Distance between two chasters block	2.30m (Men/Women and Junior Boys/Girls) 1.90m (Sub Junior Boys/Girls)
Number of innings in Kho-Kho	02 for each team (total 4 turns of 9 minutes each)
Duration of the interval	6 minutes (after first inning for both teams)
Time interval between team turns including interval time	3 minutes (9 + 3 + 9 + 6 + 9 + 3 + 9) = 48 minutes
Dimensions of the pole (Height)	1.20m to 1.25m
Diameter of the pole	9cm to 10cm
Number of players	9 playing members and 3 extra players
Officials	2 Umpires, 1 Referee, 1 Time Keeper, 1 Scorer

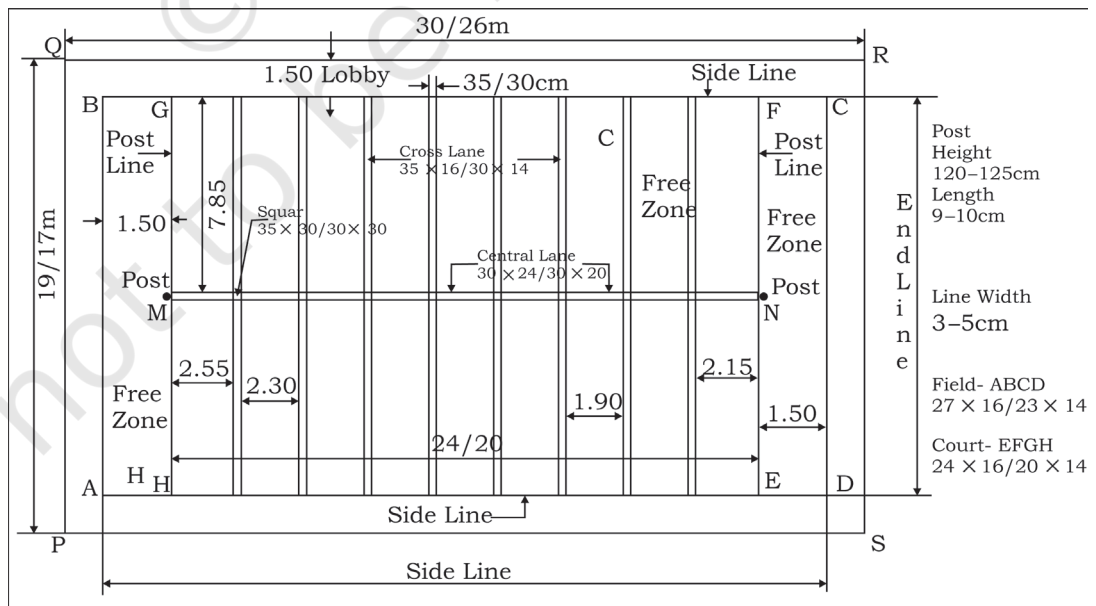

Fig. 5.47: Specifications of kho-kho playground (men/women)

Equipment

For the construction and playing Kho-Kho, the following equipment are required—

1. Posts (Two Wooden Poles)
2. Cord (for field marking only)
3. Steel measuring tape (for field marking)
4. Lime powder (for field marking)
5. Stopwatch
6. Score sheet
7. Large score board (score indicator)
8. Time indicating Plates (30 mm × 20 cm)

General rules and regulations

1. Each team consists of 12 players. Nine players play the game.
2. On the basis of the toss, the captain chooses running (defending) or chasing (attacking).
3. Nine players of the chasing team participate during the attack, out of which eight players sit on the boxes of the central lane. The players sit in the boxes alternately in such a way so as to face in opposite direction.
4. An active chaser gives a vocal signal 'kho' to the team's own sitting player with a simple tap by palm on his/her back and sits in their box. It is a violation if the sitting player moves before the kho is completed. This violation of the sitting player is termed as 'early kho'.
5. A chaser while chasing is not allowed to change the direction, but they can change the direction in rectangles known as free zones which are outside the poles.
6. If a chaser touches the runner, the runner is given out.
7. The match consists of two innings. Each team is given nine minutes for chasing (attack) and nine minutes for running (defend).
8. The running team is divided into three groups consisting of three players in each group. First group enters with the starting whistle and the second group enters when the players of first group are out and the game continues.
9. A runner is also declared out if any part of his body touches outside the playing area or moves out of the playing area while defending himself.

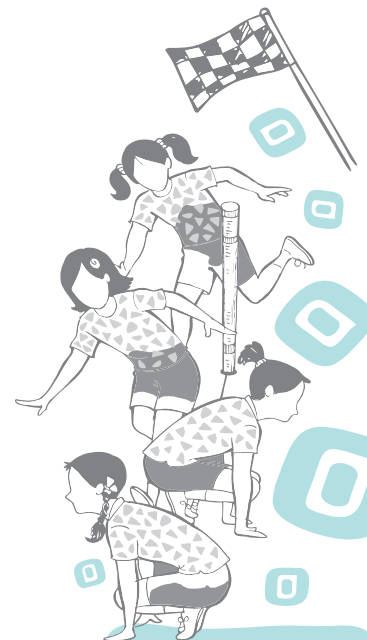

10. A substitution can be made:
 - a) for the runners team before giving the order of the runners to officials.
 - b) chasers can be substituted during the game any time.
11. After getting out, the runner should sit in the lobby accorded to his group.
12. In a match, there are two umpires, one referee, one time keeper and one scorer.

Specific exercises of warm-up and conditioning

1. Jogging, and running
2. Breath control exercises
3. Dodging and Zig-Zag running
4. Bending and stretching exercises
5. Frog jump

Fundamental skills of kho-kho

1. Types of giving Kho
 - a) Simple Kho
 - b) Beginners Kho
 - c) Late Kho
2. Method of chasing
 - a) Left hand chase
 - b) Right hand chase
3. Method of sitting
 - a) Bullet/Bunch method
 - b) Parallel method
4. Method of getting up
 - a) Monkey style
 - b) Standing up style
 - c) Combined style
5. Making the chain
 - a) Single chain
 - b) Double chain
 - c) Making a ring
6. Dodging
7. Diving
 - a) straight dive (front dive)
 - b) Sideward dive



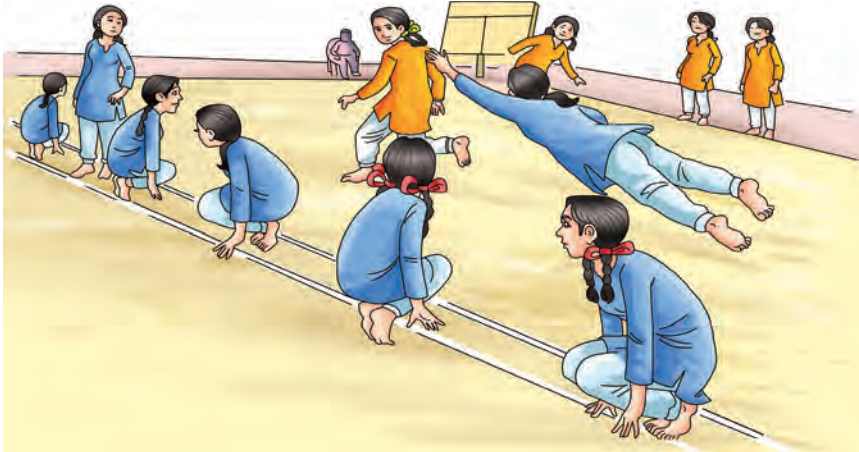

Fig. 5.48: Straight dive in kho-kho



Fig. 5.49: Side dive in kho-kho

Do You Know?

Kho-Kho is now played indoor on mats also.

Activity 5.19

Ask your teacher to organise an inter-class/inter-group Kho-Kho competition in the school.

Important tournaments

International

1. Asian Championship—started in 1996 at Calcutta
2. Netaji Subhash International Tournament—first held in 1998

National

1. Federation Cup
2. Nehru Gold Cup
3. National Kho-Kho Championship
4. Inter University Championship

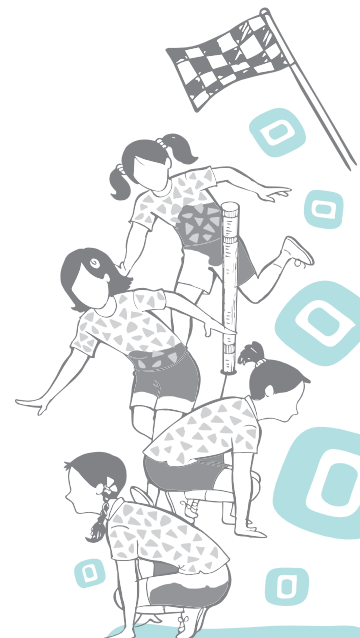

Activity 5.20

Mark a Volleyball court on the playfield in your school.

VOLLEYBALL**History of Volleyball**

Volleyball is played by two teams on a playing court divided by a net. It is one of the most successful, popular, competitive and recreational sports in the world. The game of volleyball originally called Mintonette was invented in 1895 by William G. Morgan. The Volleyball Federation of India (VFI) was formed in the year 1951. The Federation Internationale de Volleyball (FIVB) was founded in 1947. Volleyball was introduced in the Asian Games in 1958 for Men and in 1962 for Women. The FIVB Volleyball Men's World Championship started in 1949 and for women in 1952. Volleyball made its Olympic debut at the 1964 Tokyo Games.

Court Dimensions

Fig. 5.50: Volleyball court layout

- The playing court is rectangular in shape measuring 18×9 m. It is surrounded by a free zone of 5 m from the side lines and 6.5 m from the endlines.
- The height of the free playing space, above the playing area, from the playing surface, shall be 12.5 m.
- Attack line is 3 m from the axis of the centre line, which marks the front zone.
- The service zone is 9 m wide and is behind each endline. It is laterally limited by two short lines, each 15 cm long, drawn 20 cm behind the endline as an extension of the side lines.

- All lines of the court are white and 5 cm wide.
- Full Court diagonal = 20.125 m
- Half Court diagonal = 12.728 m

Equipment

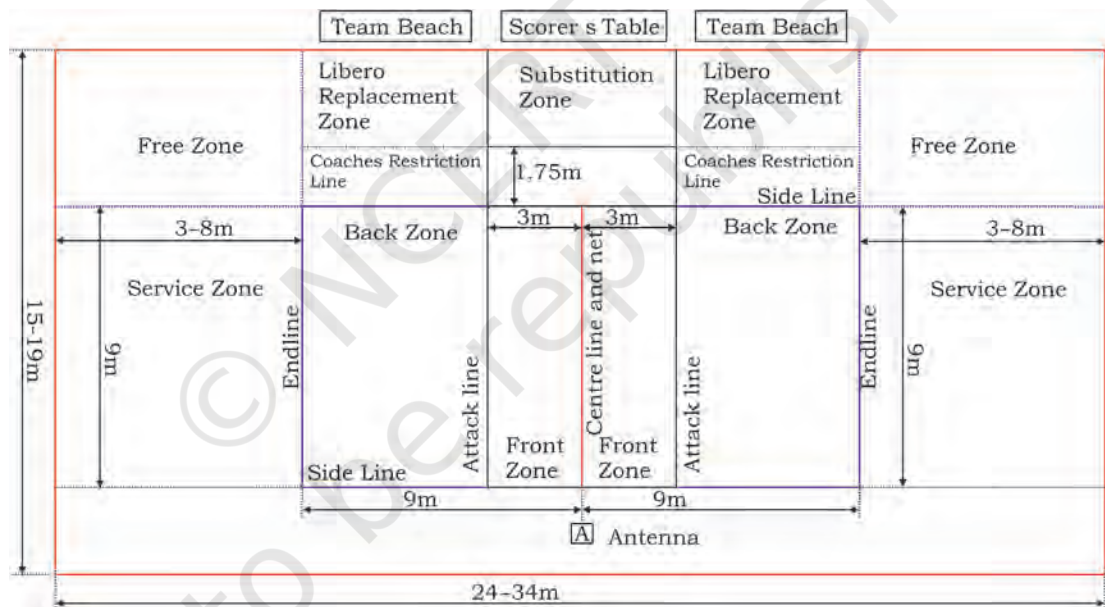
Activity 5.21

Draw a Volleyball court as per International Standards of FIVB giving all its specifications.

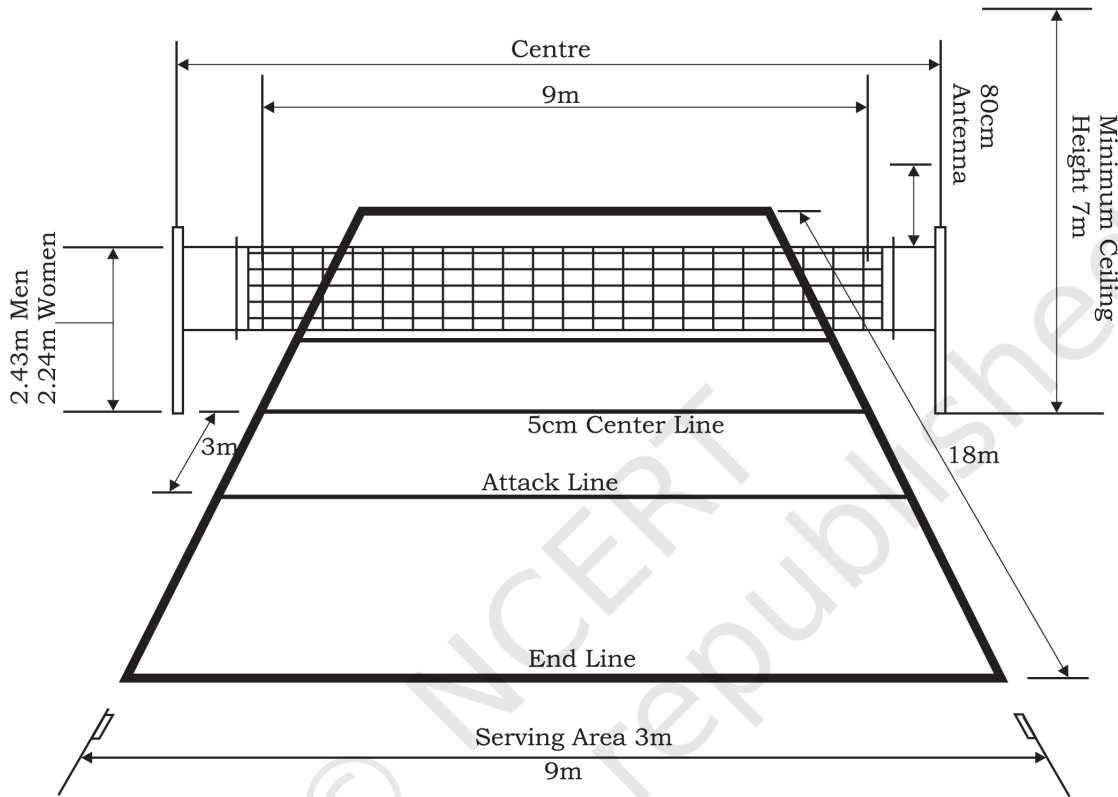

Fig. 5.51: Court and net specifications in volleyball

Ball

- The ball shall be spherical, made of a flexible leather or synthetic leather case with a bladder inside, made of rubber.
- The colour may be a uniform light colour or a combination of colours.
- The circumference is 65–67 cm and its weight is 260–280 g.
- Its inside pressure shall be 0.30 to 0.325 kg/cm².
- The height of net is 2.43 m for men and 2.24 m for women measured from the centre of the playing court.
- The net is 1 m wide and 9.50 to 10 m long, made of 10 cm square black mesh.

Preferably adjustable posts that are 2.55 m high are placed 1m outside the side lines.



Fig. 5.52: Volleyball

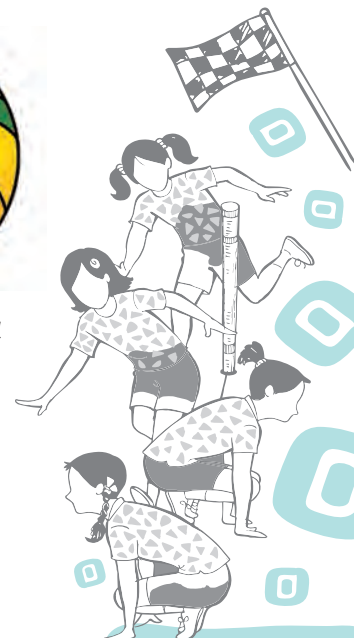

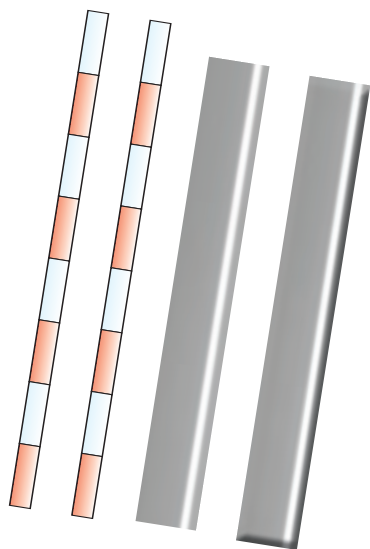

Fig. 5.53: Antenna and side bands

Antenna and Side Bands

- An antenna is a flexible, 1.80 m long and 10 mm in diameter, made of fibreglass or similar material.
- The top 80 cm of each antenna extends above the net and is marked with 10 cm stripes of red and white colour.
- Two white bands 5 cm wide are fastened vertically to the net and placed directly above each side line.

How to play volleyball

- A team consists of 12 players of which one of the players other than the Libero, is the team captain.
- Before the match, the referee carries out a toss in the presence of the two team captains to decide upon the first service and the sides of the court in the first set. If a deciding set is to be played, a new toss will be carried out.
- Before the start of each set, the coach has to present the starting line-up of six players of the team on a line-up sheet. The team's starting line-up indicates the rotational order of the players on the court. This order must be maintained throughout the set.

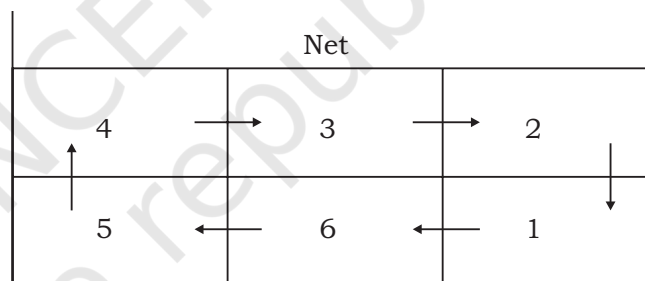

Court positions and rotation direction

Fig. 5.54: Player positions and rotation direction of players

- At the moment the ball is hit by the server, each team must be positioned within its own court, in the rotational order (except the server). The three players along the net are front-row players and occupy positions as— 4 (front-left), 3 (front-centre) and 2 (front-right); the other three are back-row players occupying positions 5 (back-left), 6 (back-centre) and 1 (back-right).
- Rotational order is determined by the team's starting line-up and controlled with the service order and players' positions throughout the set. When the receiving team gains the right to serve, its players rotate one position clockwise—the player in position 2 rotates to position 1 to serve, the player in position 1 rotates to position 6, etc.

- Each team is entitled to a maximum of three hits (in addition to blocking), for returning the ball.
- A player cannot hit the ball two times consecutively.
- A team scores a point by successfully landing the ball on the opponent's court or when the opponent team commits a fault or receives a penalty.
- A rally is the sequence of playing actions from the moment of the service hit by the server until the ball is out of play.
- If the serving team wins a rally, it scores a point and continues to serve.
- If the receiving team wins a rally, it scores a point and it must serve next.
- Each team may request a maximum of two time outs of 30 seconds each and six substitutions per set.
- A player of the starting line-up may leave the game, but only once in a set. The player may re-enter, but only once in a set, and only to the previous position in the line-up.
- All intervals between the sets are of three minutes.
- **To win a set:** A set (except the deciding 5th set) is won by the team which first scores 25 points with a minimum lead of two points.
- In the case of a 24-24 tie, play is continued until a two-point lead is achieved (26-24; 27-25; etc.).
- **To win the match:** The match is won by the team that wins three sets.
- In the case of a 2-2 tie, the deciding 5th set is played to 15 points with a minimum lead of 2 points.
- Each team has the right to designate from the list of players up to two specialist defensive players—liberos.
- The libero on court is the Acting Libero. If there is another libero, than that person is the second Libero for the team. Only one libero may be on court at any time.
- The libero player(s) must wear a uniform which has a different dominant colour from the colour of the rest of the team.
- The libero is allowed to replace any player in a back row position. The player is restricted to perform as a back row player and is not allowed to complete an attack hit from anywhere (including playing court and free zone), if at the moment of the contact, the ball is entirely higher than the top of the net.
- They may not serve, block or attempt to block.
- Libero replacements are not counted as substitutions.
- They are unlimited but there must be a completed rally between two libero replacements.

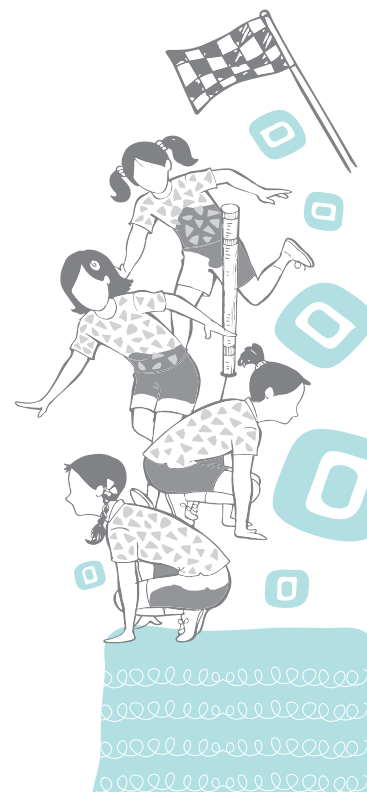

Fundamental Skills



Fig. 5.55: Under arm pass



Fig. 5.56: Over hand serves or tennis service



Fig. 5.57: Overhead pass or volley pass

1. The Service
 - (a) Tennis Service
 - (b) Jump and Serve
 - (c) Floating service
2. The Pass
 - (a) Under arm pass
 - (b) Over head pass
 - (c) Forward dive and pass
 - (d) One arm pass with side rolling
3. The Set-up
 - (a) Overhead or Volley Pass
4. The Attack
 - (a) Smash or Spike

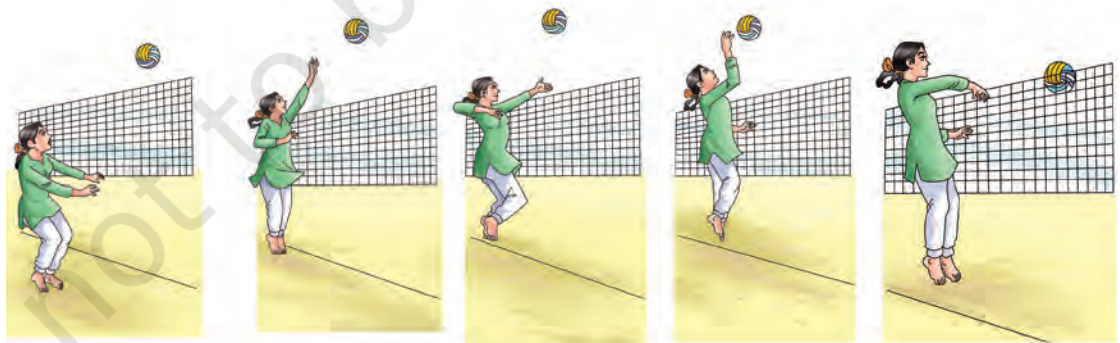

Fig. 5.58: The attack

5. The Block
 - (a) Single block
 - (b) Double block





Fig. 5.59: The block

Activity 5.22

Practice Tennis Service in Volleyball and the Physical Education Teacher will rectify your mistakes.

6. Tennis Service

- The ball is tossed with fingers, left foot forward with weight transferred simultaneously.
- The Arm is stretched in order to accelerate the ball.
- The Wrist is kept rigid with flat hand keeping the forearm and shoulder relaxed.
- Hip is rotated to move back, shoulder, elbow and hand.
- Arm is quickly accelerated towards the ball, to hit it with base of the palm.
- The hitting arm and the body moves forward stepping with the rear foot.

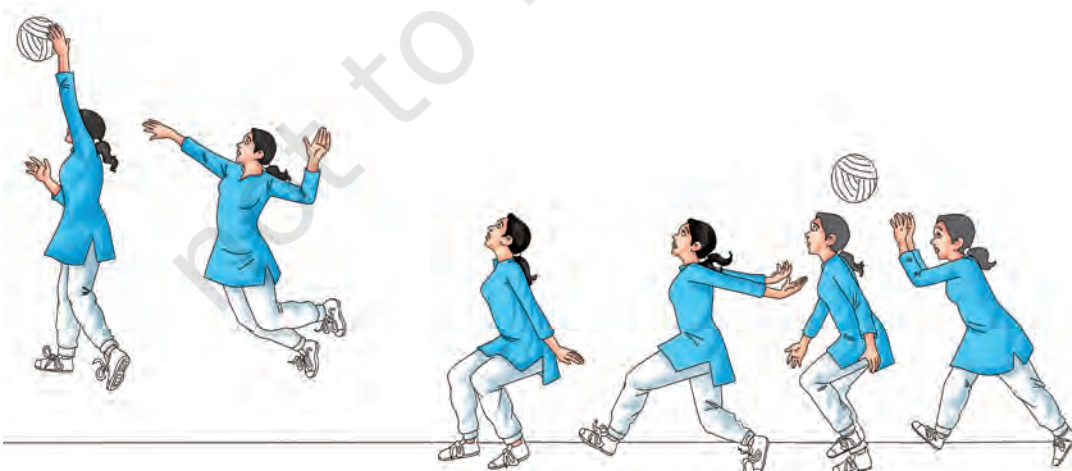
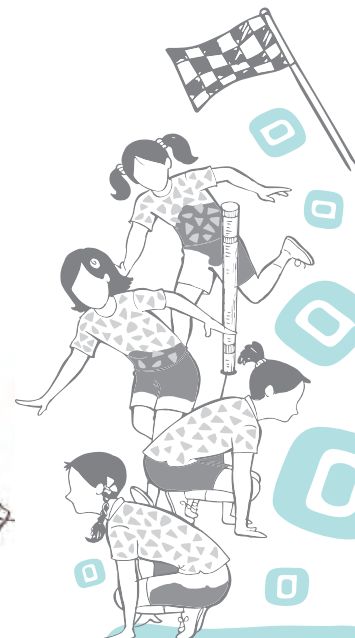

Fig. 5.60: Jump serve



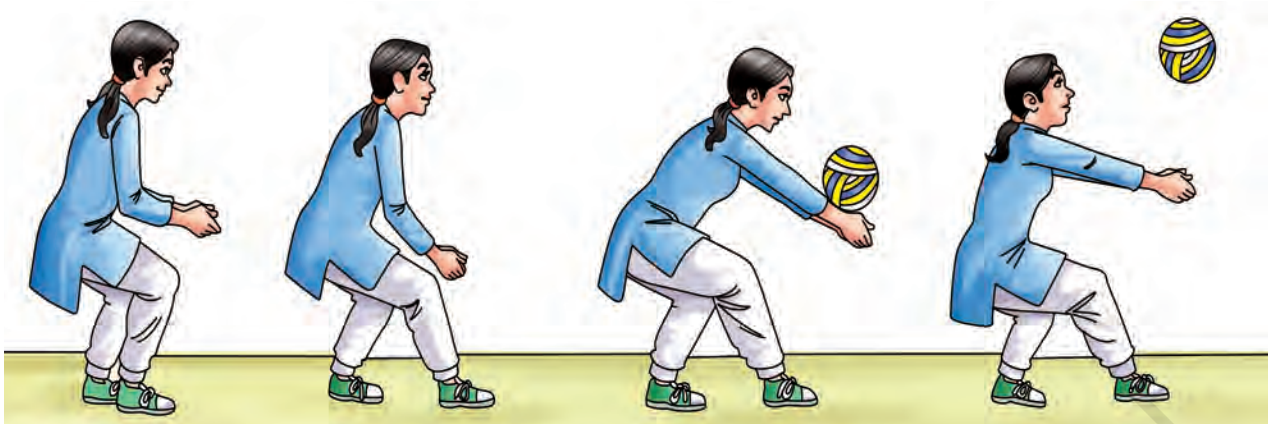

Fig. 5.61: Under arm pass

7. The pass

- (a) **Under arm pass:** This skill is used when the ball is below your forehead to receive a striking ball or dropped ball, etc.
- (b) **Overhead pass:** This skill is used when the ball is high, above the player's shoulders/head and generally used to receive the service to set a ball or receiving a loose crossed ball.
- (c) **The set-up:** Set-up skill is generally a second contact with the ball in order to set up a spike for another player. This skill is used to spike a ball or drop the ball into the opponent's court.

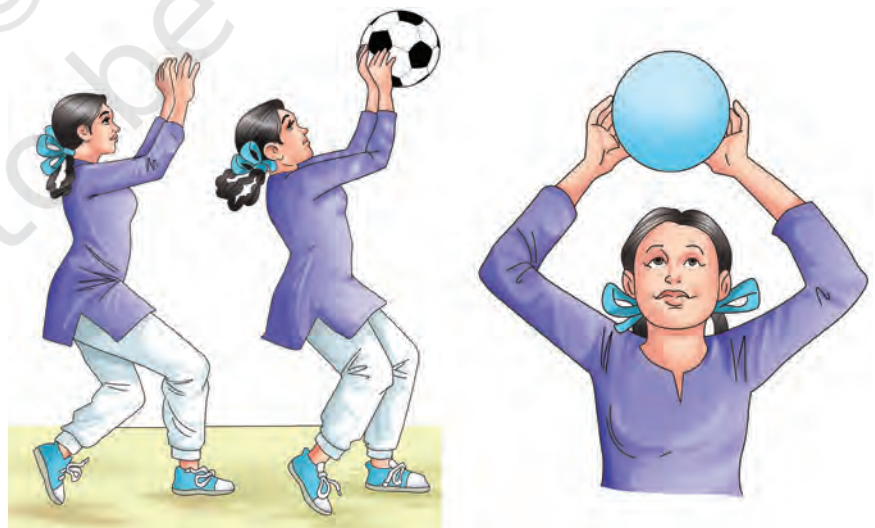

Fig. 5.62: Overhead pass (Left), set-up (Right)



- (d) **The Serve:** It is used to put the ball into play, to start the volley and this skill is solely executed by one player. It is further classified into mainly three parts.
- (i) Tennis Service
 - (ii) Jump Service
 - (iii) Floating Service

Activity 5.23

Play a Volleyball match between two teams of your class. Use libero, substitutions and time outs as per rules.



Fig. 5.63: Floating service

- (e) **The Attack:** In this skill, a player attempts to hit the ball from over the net towards the opponent court with the aim to score a point. It is executed from the front zone as well as the back zone.
- (f) **The Block:** In this skill, a player attempts to stop the opposite team from hitting the ball into his or her court. By using block technique, a player stops the opposite team from scoring a point.

Awards in Volleyball

To motivate the extraordinary achievements of the players and Coaches, the Government of India honours players with different awards along with cash prizes and certificates.

Tom Joseph was the recipient of Arjuna Award in 2014.

G.E. Sridharan was honoured with Dronacharya Award for his excellent contribution as a Coach in the year 2007.

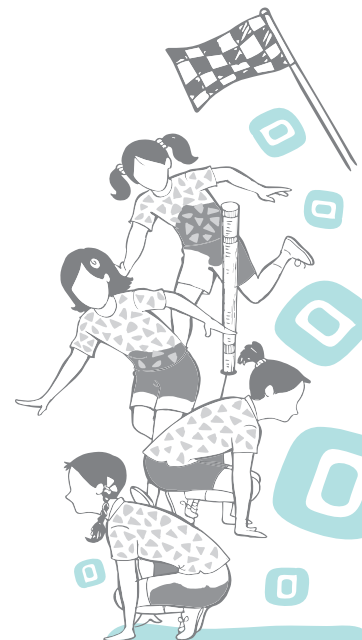

ASSESSMENT

BASKETBALL

I. Long Answer Questions

1. Explain the reason behind invention of Basketball by Dr. Neismith.
2. What are the reasons of basketball's development at such a fast pace?
3. Discuss the functional rules of basketball.
4. Explain the four fouls in basketball.

II. Short Answer Questions

1. What is the full form of FIBA?
2. Who is known as the father of basketball?
3. What is the full form of BFI?
4. When was the first set of basketball rules framed?
5. What is the height of basketball ring from the floor?
6. What is the weight of the basketball?

III. Fill in the Blanks

1. The first national basketball championship was held in _____ under IOC.
2. Basketball become a regular part of Olympics officially in the year of _____.
3. Basketball game is divided into _____ quarters.
4. Circumference of a basketball is _____.

IV. State whether True or False

1. The first national championship under BFI was conducted in 1951.
2. Three seconds rule is related to violation.
3. The boundary lines are a part of playing area in Basketball.

CRICKET

I. Long Answer Questions

1. Write down the international and Indian history of cricket.
2. Explain the 11 ways through which a batsman can be given 'out' in the game of cricket.



3. Elaborate the different types of bowling in cricket.
4. Explain the different types of batting in cricket.

II. Short Answer Questions

1. When and where was the BCCI framed?
2. What is the old and new full form of ICC?
3. What is T20?
4. What is a Wide Ball?
5. Who was the recipient of Rajiv Gandhi Khel Ratna Award in 2018?

III. Fill in the Blanks

1. Cricket is a game played with a _____ and _____ on a large field, known as a _____.
2. First Indian batsman who scored century in Test Match was _____.
3. First Indian batsman who scored century in One day match is _____.
4. The colour of cricket ball should be _____ in night test matches.

IV. State whether True or False

1. There are two types of crease.
2. The height of stumps is 28 inches.
3. A 'Bye' run is scored when a batsman is trying to hit the ball but could not hit it and is miss-field by the fielder or wicket keeper.
4. A batsman is not out if he willingly obstructs the opposition by word or action.

FOOTBALL

I. Long Answer Questions

1. Explain the world history of Football.
2. Draw a labelled football ground.
3. Explain any five laws of football.
4. What are the players' equipment in football?
5. List the types of kicks in football and explain any two.



II. Short Answer Questions

1. When was the first Football Association formed?
2. Tsu-Chu was played in which country?
3. What is FIFA?
4. When was AIFF formed?
5. What are the dimensions of a football field for international competitions?
6. List the criteria as per FIFA for the football to be used.
7. What is the difference between free kick, indirect free kick and penalty kick?

III. Fill in the Blanks

1. The game of football is also known as _____ in the world.
2. The first known/oldest football tournament is _____.
3. India holds the record of organising _____ cup as second oldest tournament in the world.
4. Less than _____ players cannot be allowed for a team to play in tournament.
5. Two yellow cards are equal to _____ which means sending off offence.

IV. State whether True or False

1. The Throw-In is a method of restarting play.
2. The measurement of a goal area is 5.5m × 19m.
3. A goal can be scored directly from the indirect free kick.
4. A direct free kick, kicked in own goal is awarded as corner to opponent.
5. Unsporting behaviour is a questionable offence.
6. A direct goal can be scored from the corner kick but only against the opposing team.
7. A flag post should not be less than 1.5m (5 feet).

HANDBALL

I. Long Answer Questions

1. Write down the History of Handball.
2. Draw a labelled handball playfield.

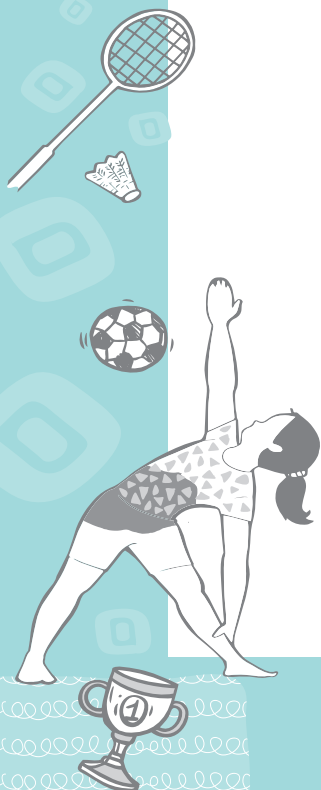

3. Explain the functional rules of Handball.
4. Differentiate between the 6 m Goal Area Line and 9 m free throw line.

II. Short Answer Questions

1. What is the full form of IHF?
2. When and where was the IHF framed?
3. How many players and substitutes are there in a Handball team?
4. Write down the names of the current Indian Handball team members?

III. Fill in the Blanks

1. The first national handball championship was held in _____.
2. Handball became a regular part of Olympics officially in the year of _____.
3. Time out is related to _____ quarters of playing time.
4. Panalty line is _____ away from the Goal Post.

IV. State whether True or False

1. The first World Championship under IHF was conducted in 1954.
2. 3 seconds rule is related to violation.
3. The length of a Handball ground is 42 m.

HOCKEY

I. Long Answer Questions

1. Who founded the International Hockey Federation and in which year?
2. In which year was hockey introduced in the Olympic Games.
3. Draw a labelled diagram of hockey field playground.
4. Explain in detail the new match time format in field hockey.
5. Explain the new format of shootout in field hockey.



II. Short Answer Questions

1. What is the full form of FIH?
2. What is the weight of a field hockey ball?
3. What should be the shape of the head of a hockey stick?
4. How many umpires are there in field hockey?
5. How many types of cards can be issued by the umpire in field hockey? What is the effect of yellow card on a player?

III. Fill in the Blanks

1. The height of the goal post in field hockey is _____.
2. The player is suspended for _____ minutes if he gets a green card.
3. National championship for field hockey is _____.
4. The duration of a field hockey match is _____.
5. The international field hockey match played is _____ quarters of _____ minutes.
6. Indian men's Hockey team won _____ gold medals in Olympic Games.

IV. State whether True or False

1. A player is suspended for 5 minutes when the umpire shows yellow card to the player.
2. The height of the backboard in goal post is 480 mm.
3. The height of the flag post is 2.00 m.
4. Field hockey was first introduced in 1900 Olympic Games.

KABADDI

I. Long Answer Questions

1. Briefly explain the origin of Kabaddi as a game in India.
2. Describe any three rules of giving raid.
3. What are the situations in which the raider can be given 'out'?
4. How does an anti-raider team get points?
5. How can a bonus point be scored?



II. Short Answer Questions

1. Name the place from where Kabaddi has originated?
2. When did Kabaddi receive international exposure?
3. How many players play in a Kabaddi match?
4. What is 'lona'?
5. What is the duration of time out in a Kabaddi match?
6. Enlist some defensive fundamental techniques mostly used in Kabaddi.
7. What does green card indicate in Kabaddi?

III. Fill in the Blanks

1. The game of Kabaddi has been developed and played since the epic age of _____.
2. The surface for playing Kabaddi game in present day is _____.
3. A raider is allowed to chant only _____.
4. A raider cannot be held by his _____ or _____.
5. When all the members of a team are made out by the opponents, it is called _____.

IV. State whether True or False

1. To warn a player, the umpire shows green card.
2. Temporary suspension of 4 minutes is given by yellow card.
3. Red card is given to a player for suspension from the match.
4. A raider gets 1 point for crossing the bonus line only when there are minimum 6 defending players.
5. In the case of tie match in knock-out tournament, five raids are allowed from both the teams.

KHO-KHO

I. Long Answer Questions

1. Explain the history of Kho-Kho.
2. Draw a Kho-Kho court according to the specifications.
3. Describe some fundamental skills of Kho-Kho.
4. Write about the important national and international tournaments organised in Kho-Kho.



5. Explain the general rules and regulations of Kho-Kho.
6. Explain the dimensions of the Kho-Kho ground for women.

II. Short Answer Questions

1. Define 'chasers'.
2. State the height of the pole in Kho-Kho.
3. Can a runner touch the sitting chaser?
4. Is a player considered out, if his both feet are outside the playing court?
5. Name the basic techniques of Kho-Kho.
6. Who was the first Kho-Kho player to get the Arjuna Award?
7. Can the chasers finish their turn before the allotted time?
8. Will the defenders have to come again, if they are all out before the time?
9. What are the dimensions of each square for men's playfield?
10. How many points are awarded if a runner is out?
11. How many officials are required in a Kho-Kho match?
12. Name some of the famous players of Kho-Kho.
13. How many players are there in a Kho-Kho team?
14. How many innings are there in a Kho-Kho match?
15. What is the total duration of a Kho-Kho match?
16. Who had given the modern form to Kho-Kho?

III. Fill in the Blanks

1. For the first time, the rules of Kho-Kho were framed in the year _____.
2. The modern frame of the game is credited to _____.
3. The governing body of Kho-Kho in India is _____.
4. Asian championship started in _____.
5. Chaser in Kho-Kho is also called _____.

IV. State whether True or False

1. Hanuman Vyayam Prasarak Mandal has given the modern form of Kho-Kho.
2. Kho-Kho federation of India was established in 1940.
3. Eleven players play in a Kho-Kho game.



4. Running team is divided into three groups consisting three players each.
5. The Kho-Kho game develops agility.

VOLLEYBALL

I. Long Answer Questions

1. Explain the international and Indian history of Volleyball game.
2. Explain about 'libero' in Volleyball.
3. Write down the scoring system in Volleyball.
4. Explain about the fundamental skills of Volleyball.

II. Short Answer Questions

1. When was the Volleyball Federation of India (VFI) formed?
2. When was the Federation Internationale de Volleyball (FIVB) founded?
3. List the equipment used in Volleyball.
4. Write down the fundamental skills of Volleyball.
5. Name the types of services in Volleyball.
6. What is 'attack' in Volleyball?
7. Who was the recipient of the Arjuna award in 2014 in Volleyball?

III. Fill in the Blanks

1. In Volleyball, the height of the free space above the playing area from the playing surface shall be _____ m.
2. Diagonal measurement of full Volleyball court shall be _____ m.
3. A team may request a maximum of _____ substitutions per set.

IV. State whether True or False

1. Volleyball was introduced in 1964, Tokyo Olympic Games.
2. Federation Internationale de Volleyball (FIVB) was formed in 1949.
3. Libero cannot serve, block or attempt to block.





YOGA AND ITS RELEVANCE IN THE MODERN TIMES



Fig. 6.1: Yoga mudra

Yoga is a science of living. It needs to be incorporated in daily life. It works on physical, mental, emotional, social and spiritual levels of human beings. Yoga helps in improving the quality of life. For example, yoga teaches us how to think, behave and grow to become a fully mature person. Yoga brings harmony between body and mind. It is an art and science for healthy living.

The word 'yoga' is derived from the Sanskrit word 'yuj' meaning to join, to yoke, and to unite. It is an ancient system of self-development and natural process of evolution of human beings.

Now a days, the word yoga has a strong impact on human life. The ultimate purpose of yoga is the attainment of human growth. Yoga has been established as a new field in education system. It helps in achieving higher state of consciousness on the evolution of an individual's development. It is the discipline of body and mind.

Children face too much stress in their surroundings, such as, school, home, playground, etc. Due to this stress they have many problems such as physical, mental and emotional. When these health hazards create problems for long, they lead to psychosomatic diseases and social unrest. All these problems originate due to imbalance between our physical, mental and spiritual levels. They are closely related to materialistic way of life. Attachment and endless ambitions are the two primary causes of our sufferings.

According to the Upanishads, yoga is a higher state of consciousness and a process to ease the mind and manifest the wisdom. Yoga establishes the activities of a healthy state of body, mind and harmonious interpersonal relationships. Due to unhealthy lifestyle, the overall growth of child gets ceased and it leads to ill health. Yoga works on various

aspects of human body and mind and helps to improve self-awareness, self-control, relaxation, concentration, flexibility and coordination.

HISTORY AND DEVELOPMENT OF YOGA

Yoga has a very long history and in terms of legacy it is as old as human civilisation. Its history is also linked with the *vedas* and *upanishads*.

Yoga had a special place during the Indus Valley Civilisation (2000 B.C). The stone seals restored from the sites of the Indus Valley Civilisation depict the practice of Yoga during old days.

The word yoga is frequently referred in all the four *Vedas Rigveda, Yujurveda, Samveda* and *Atharvaveda*.

Moksha is the ultimate goal of yoga, which is well explained in the *Upanishads*. The teaching of Buddha (*Arya Asthanga Marga*) and Jainism (five great vows) are the two pillars of yoga tradition. These two had greatly contributed to the development of yoga.

The epics: *Ramayana* and *Mahabharata* have numerous references about yoga. The *Bhagavad Gita* is considered as a classical treatise on yoga.

There is also description of Yoga in *Shad Darshans*.

Maharishi Sage Patanjali had codified the comprehensive system of Yoga around second century B.C. Patanjali gave the concept of eight limbs of yoga called as *Ashtanga Yoga*.

Nath culture also played an important role in the development of the *Hatha Yoga* Tradition. *Hatha Yoga* deals with day-to-day health related problems and emphasised on the human body and mind. The famous scriptures of *Hatha Yoga* are *Hatha Yoga Pradeepika, Gheranda Samhita, Hatha Ratnavali, Shiva Samhita, Siddha Siddhanta Paddhati*, etc. Nineteenth century gurus, such as, Ramakrishna Parmahansa, Swami Vivekananda, Maharishi Aurobindo and Ramana Maharishi preached yoga to the masses.

SCHOOLS OF YOGA

The basic goal of yoga is thus to attain bliss and also to provide true knowledge about human beings. In order to attain the above goals, various thoughts, ideas and opinions were given by seers which are known as the schools of yoga. These are—

Karma Yoga (Path of Action)

Karma Yoga is one of the main streams of yoga. *Karma* literally means action. The aim of *Karma Yoga* is attaining union with the higher-self by harmonising the actions.



Fig. 6.2: Vedas

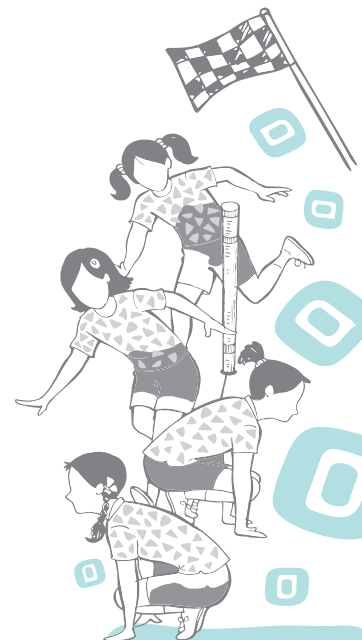



Fig. 6.3: Swami Vivekanand

Karma Yoga inspires the person to perform the work to the best of their abilities without any attachment or expectation of the results. The concept of *Karma* Yoga and its practice are mentioned in the *Bhagavad Gita*. This stream of yoga emphasises the following.

- **Karma as duty:** Karma Yoga lays emphasis on doing karma or action as duty. When an act is performed dutifully with total involvement, it leads to joy and happiness.
- **Karma Sukaushalam:** *Karma* Yoga states that yoga means a skilled action. Actions should be done efficiently. Actions performed with full concentration and detachment brings efficiency.
- **Nishkama Karma:** *Nishkama Karma* means action which is free from personal motives and is performed as a duty. This attribute emphasises that actions should be performed without any expectations of the results.

Jnana Yoga (Path of Knowledge)

- *Jnana* Yoga is related to the knowledge of 'self', the world and realisation of ultimate reality or truth. *Jnana* Yoga, thus is a path of philosophy that uses intellect and helps to gain knowledge and keeps the person away from *avidya*.
- *Avidya* (ignorance) is the main cause of pain, misery and sufferings in life. A person because of *avidya* (ignorance) identifies himself with various names, and forms such as body, mind, race and nationality, etc., and remains in pursuit of worldly possessions. This knowledge develops discriminating knowledge (*Viveka*) that will help to remove the veil of *avidya*, enables the one to discriminate between reality and unreality (appearance) and guides towards the path of real happiness and bliss.
- The main aim of the *Jnana* Yoga, thus is to overcome the *avidya* (ignorance) so that one can understand and distinguish between the real and unreal. The three important stages of *Jnana* Yoga are *shravan* (adequate hearing), *Manana* (constant remembrance) and *Nidhidhyasana* (contemplation or meditation).

Raja Yoga (Path of Psychic Control)

- The science of *Raja* Yoga proposes a practical and scientific method of reaching the truth. *Raja* Yoga, the path of psychic control is a systematic process of culturing the mind.

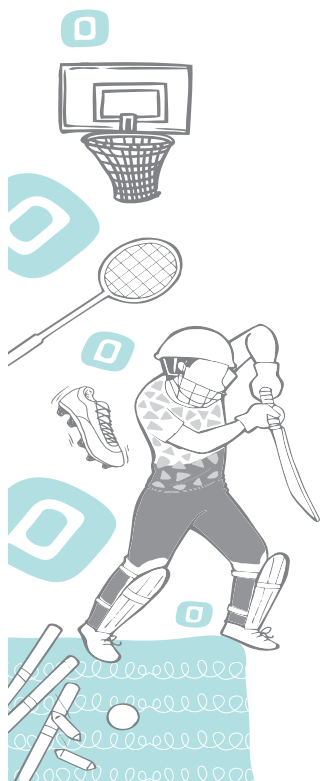

- It is aimed to develop dormant potential of the personality.
- *Raja Yoga* discusses the way of controlling and modification of mind (*chittavrittis*).
- *Abhyasa* (continuous practice) and *viaragya* (detachment) are also emphasised in *Raja Yoga* for the control of *chittavrittis* and spiritual practices.
- *Raja Yoga* is based on *Ashtanga Yoga* (eight limbed Yoga) as propounded by Maharishi Patanjali.
- All the eight limbs of yoga work on various levels of human personality.

Bhakti yoga (Path of Devotion)

- *Bhakti Yoga* (path of devotion) is a systematic method of engaging the mind in the practice of divine love. *Bhakti* means selfless and unconditional love to god. This mode of worship consists of unending and loving remembrance of God. The person merges himself/herself with the God.
- The attitude of love and devotion has the softening effect on emotions and calms down the mind. There are nine forms of *Bhakti Yoga* mentioned in ancient text. These are *Shravan, Kirtan, Smaran, Padsevan, Archana, Vandana, Dasya, Sakhya, Atmanivedan.*

GUIDELINES FOR YOGA PRACTICE

The guiding principles given below should be followed by the *Sadhakas* performing the yogic practices.

Before the yogic practice

- *Shauch* means cleanliness, an important pre-requisite for Yogic practice.
- It includes the cleanliness of surroundings, body and mind.
- Yogic practices should be performed in a calm and quite atmosphere with a relaxed body and mind.
- Yogic practices should be performed on an empty stomach.
- Bladder and bowels should be emptied and evacuated before starting yogic practice.
- Yogic practice should not be performed on uneven surface.
- A mattress, *durry* or folded blanket should be used.
- Light and comfortable cotton clothes are preferred to facilitate easy movements of the body.
- These practices should not be performed in a state of exhaustion, illness or in a hurry.

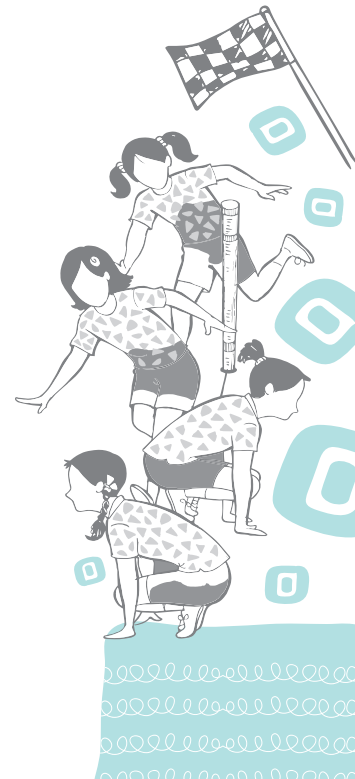

During the practice

- Practice session should start with prayer as it creates conducive environment and thereby relaxes the mind.
- Perform the practice slowly with body, breathe awareness along with relaxation.
- Breathing should always be done through nostrils unless instructed otherwise.
- Observe your body movements, do not strain too much. Practice as per your own capacity.
- Regular practice is very essential for good results.
- There are contra-indications/limitations for each *Asana*, *Pranayama*, *Kriya* and *Bandha*. Such contra-indications should always be kept in mind. In case of chronic diseases or cardiac problems, doctor and yoga therapist should be consulted prior to the performance of yogic exercises.
- During pregnancy and menstruation, yoga expert should be consulted prior to yogic practice.

After the practice

- Bath may be taken only after 15 to 30 minutes of the yoga practice.
- Light food may be taken only after 15 to 30 minutes of the yoga practice.
- After each practice session, *shavasana* should be practised as per need.
- Yoga session should end with meditation followed by deep silence and then *Shanti Path*.

YOGIC PRINCIPLES AND PRACTICES FOR WELLNESS

- Wellness is a state of being healthy. Yoga promotes wellness by bringing harmony between various dimensions of wellness namely physical, emotional (neutral), intellectual, social, environmental and spiritual health.
- Yoga is an art and science of healthy living. It is a spiritual discipline based on an extremely subtle science, which focuses on bringing harmony between body and mind.
- For wellness, we have to maintain balance among various aspects of life like physical, mental, social and spiritual.
- Adolescence is the time when an individual undergoes tremendous physical, emotional and psychological changes. This brings stress.



- Yoga is the proven remedy for all the causes of stress and strain among the adolescence.
- Regular practice of yoga amongst the students leads to improved concentration, reduced blood pressure, better grades in the academics, improved interpersonal relationships, more confidence, better sleep, calmness, sharper brains, relief from headache if any and decreased absenteeism and aridness.
- The following are few of the mechanisms through which yoga works for wellness.
 - *Shodhana Kriyas* cleanse the accumulated toxins through various *shuddikriyas* and *sukshnavyayama* (simple movements for all body parts).
 - Adoption of a yogic lifestyle with proper nourishing diet creates positive antioxidant enhancement thus, neutralising the free radicals.
 - *Yogasana* steadies the entire body through different physical postures. Physical balance and a sense of ease with oneself enhance mental/emotional balance and enable all the physiological processes to occur in a healthy manner.
 - *Pranayama* helps to improve control over autonomic respiratory mechanisms, through breathing patterns that generate energy and enhance emotional stability.
 - *Dharana* helps to focus the mind positively on the activities being done, enhances energy flow and results in healthy blood circulation to the different body parts and internal organs.
 - *Dhyana* creates a calm internal environment through contemplative practices. Mental balance produces physical balance and vice versa too.

YOGA FOR WELLNESS

Shodhanakriya

It is practiced for internal purification. These are followed in *Hatha Yoga*. It helps to clean the accumulated toxins and generates a sense of relaxed lightness.

Neti

Neti is a *Hathayogic Kriya*, which is concerned with the cleaning of nasal passage. This practice involves cleaning up the throat as well. *Neti* is a pre-requisite for cleaning up the respiratory passages for the proper practice of *Pranayama*. There are two types of *Neti*.

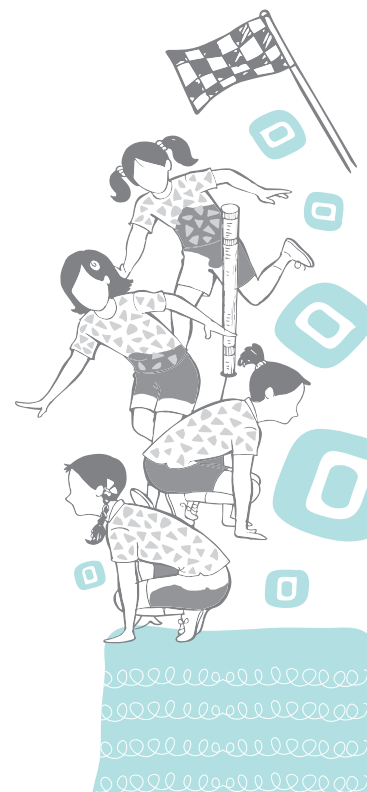



Fig. 6.4: Jala neti

Do You Know?

An expert can perform Sutra Neti together with both nostrils.



Fig. 6.5: Sutra neti

Jala neti (nasal cleansing with water)

In *Jala Neti*, water is used for cleansing the nasal passage.

Steps for practising Nasal *Neti* are—

- Sit in *Kagasana*. Keep 1.5 to 2 inches distance between the feet.
- Lean forward from the lower back.
- Tilt the head to the opposite side of the nostril whichever is more active in breathing at the moment.
- Insert the nozzle of the pot into the nostril whichever is active in breathing at that moment.
- Slightly open the mouth and breathe through it.
- Keep the body relaxed.
- Let the water flow in through one nostril and out through the other nostril.
- During the process, eyes should focus on the water stream flowing out of the nostril.
- After finishing half of the water, the put down the pot and clear the nose. Repeat with the other nostril.
- Clear the nose.
- Clean the nose through the practice of *Mukha Dhauti* (forceful exhalation from nose and passive inhalation from mouth).

Dos and Don'ts

- During the practice of *Jala Neti*, breathing should be done from mouth.
- Ideal time to perform is before sunrise, lukewarm salted water is to be used for this *kriya*.
- Head should not be tilted much during the practice of *Jala Neti*.
- Do not blow the nose too hard after the practice as the remaining water may be pushed to the ears.

Benefits

- This exercise is excellent for the cases of chronic headache, insomnia, drowsiness and improves eyesight.
- The diseases peculiar to the nose, and also coughs are effectively cured.
- Effective for stress and anxiety.

Sutra neti (nasal cleansing with thread)

According to yogic text, insert a soft thread through the nose to the length of one hand span so that it comes out of the mouth. This is called *Sutra Neti*.

Stages for Practice

- Sit in *Kagasana*.
- Tilt the head slightly back and insert the *sutra* (thread or rubber catheter) into one of the nostrils, whichever is more active in breathing at the moment. Gently push it through the nostril using both hands.
- When the thread (*sutra*) has come through to the back of the throat, put the index and middle fingers into the mouth; catch hold of the *sūtra*; and draw it out carefully through the mouth. Leave a few inches of the thread hanging out of the nose.
- Now, slowly and gently pull the thread forward and backward 4–5 times.
- Slowly take the thread out through mouth and repeat the practice through the other nostril.

Dos and Don'ts

- Insert the thread slowly and breathe continuously. The thread should be clean.
- This practice should be performed under guidance.
- Do not try *Sutra Neti* unless *Jala Neti* is perfected.
- Do not apply force while inserting the thread.
- Do not rub the *Sutra* too fast during practice.

Benefits

- *Sutra Neti* stimulates the nerves and improves the function of eyes, tear ducts and olfactory zone in the brain (nasal zone).
- It massages the membranes and sinus glands and strengthens them.
- It increases resistance to invasion by viruses.
- It is very effective in ENT problems.

Kapalbhati

Kapala means skull (head) and *Bhati* means to shine. Because this practice makes the skull (head) shine, therefore it is called *Kapalbhati*.

In other words, it rejuvenates the skull (head) and the mental functions.

Stages for Practice

- Sit in a meditative posture, eyes closed and the whole body relaxed.
- Inhale deeply through both nostrils expanding the abdomen and exhale with a forceful contraction of the abdominal muscles.

Do You Know?

An expert can perform 300 strokes of *Kapalbhati*.



Fig. 6.6: Kapalabhati

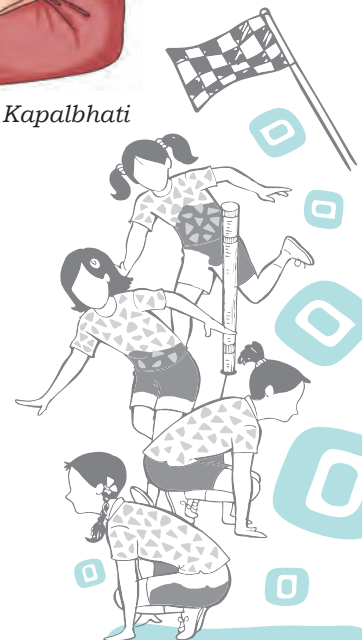

Do You Know?

An expert practitioner can perform more than 20 movements in one time.



Fig. 6.7: Agnisara

- The breathing must be of the 'bellows' type and perform 30–40 strokes in one round. Start from 10 strokes.
- At the end of practice, deep exhale and relax.

Dos and Don'ts

- Stroke should be in rhythmic manner.
- Active exhalation and passive inhalation.
- Don't strain the facial muscles during the practice.
- Avoid performing the practice in the case of high blood pressure, heart diseases and gastric ulcers.

Benefits

- It purifies the frontal air sinuses and stimulates the brain.
- Massages abdominal organs; and improves digestion.
- It increases the capacity of lungs.
- It is useful in treating cold, rhinitis (inflammation of the mucus membrane of the nose), sinusitis and bronchial infections.

Agnisara

Agnisāra is also known as *Vahnisara*. *Vahni* and *Agni* are synonymous words meaning fire and 'Sāra' means essence. According to Hatha yogic tradition, the essence of fire is located in the navel region. During this *kriya*, there is a movement in navel region. It can be performed in sitting or standing position.

Stages for Practice

- Stand erect with the feet apart at shoulder level.
- Bend the knee and body at an angle of 60°. Place the hands on thighs above the knees.
- Exhale completely then contract and expand the abdominal muscles rapidly for as long as comfortable while retaining the breath outside.
- Then slowly breathe in. Repeat the practice 2–3 times.

Dos and Don'ts

- Stomach should be empty while performing *Agnisara*.
- The movement should be in rhythmic manner.
- Don't hold the breath beyond capacity.
- Avoid performing this practice in case of high blood pressure.

Benefits

- It gives gentle massages to abdominal organs, and improves digestion.
- It reduces fat and strengthens the abdominal muscles.



- It stimulates the relevant nerves and harmonises all the abdominal conditions of the bowel, liver, kidney, spleen, pancreas and digestion, allowing optimum assimilation of nutrients.

Do You Know?

Surya namaskara can be performed with *mantra*.

SURYA NAMASKARA OR SUN SALUTATION

Surya or the sun is the primal cause of everything. It gives energy to all the living beings on the earth. *Surya namaskara* is the set of seven asanas in twelve steps. Every morning performing it with breathing techniques, energises the whole body and mind.

Technique

Starting position—stand erect with feet together and arms by the side of the thighs; balance the body equally on both the feet (*samasthiti*).

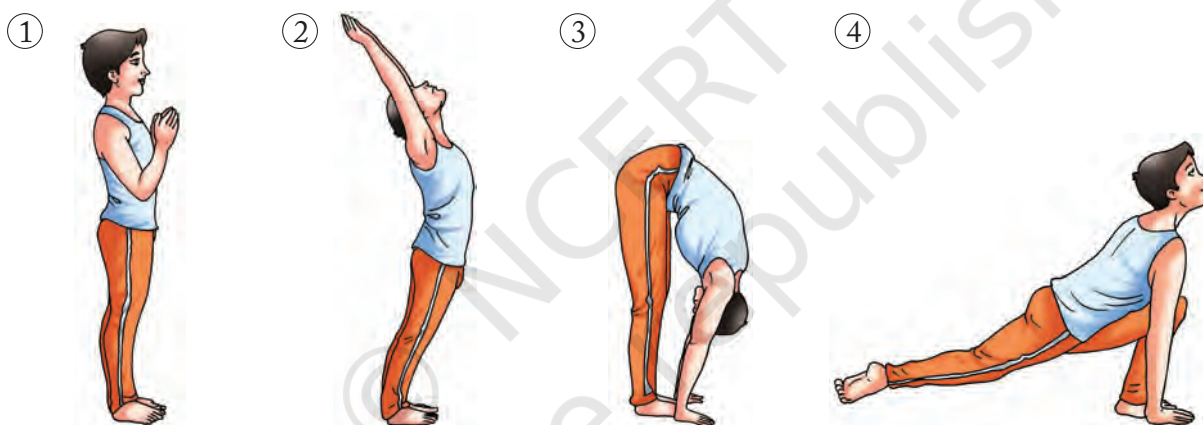
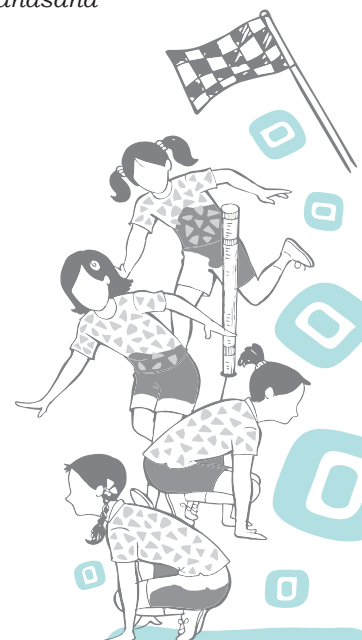

Fig. 6.8: 1. Namaskarasana 2. Hastottanasana 3. Padhastasana 4. Ashwasanchalanasana

1. **Namaskarasana:** Inhale, bring the arms up and with exhalation join the palm together in *Namaskara mudra* in front of the chest.
2. **Hastottanasana:** Inhale, raise both the arms up; stretch the body as much as possible and bend backwards without bending the knees.
3. **Padhastasana:** Exhale, bend forward from the lower back keeping the spine straight. Place the hands on the ground by side of the feet. Try to touch the forehead to the leg without bending the knees.
4. **Ashwasanchalanasana:** Inhale, place the right leg back as far as possible and touch the knee of right foot on the ground. Bend the left leg from the knee and keep the knee and foot at right angle; arching the spine back and look up between the eyebrows centre.

Activity 6.1

- Prepare a model of *Surya Namaskara*.
- Conduct competition between class.



5. **Parvatasana:** Stretch the left foot backward by the side of right foot, lower your head and move the buttocks upwards. Keep the arms and legs straight and heels on the floor.
6. **Ashtanga Namaskarasana:** Lower the knees, chest and chin to the floor. Keep the hips slightly up. The toes, knees, chest, hands and chin should be touching the floor.

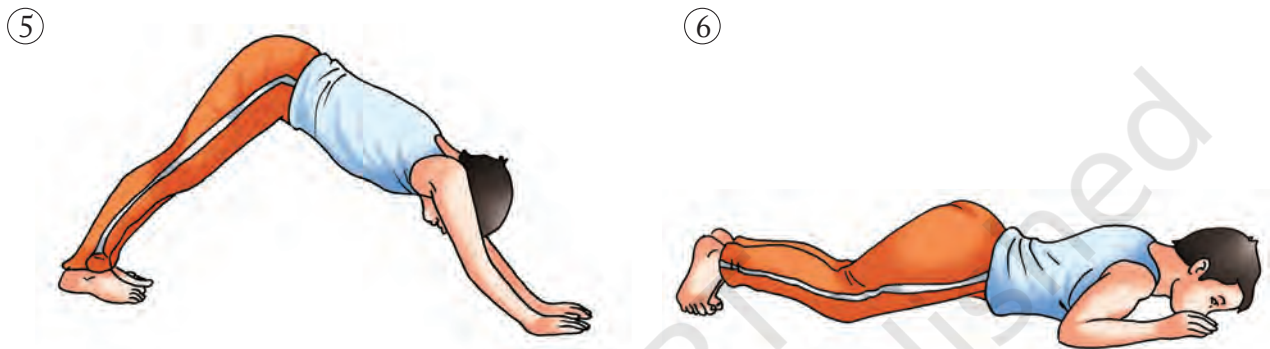

Fig. 6.9: 5. Parvatasana, 6. Ashtanga namaskarasana

7. **Bhujangasana:** Lower the hips, inhale, then raise the head and push the chest up. Raise the upper body upto the navel. Keep the palms on the ground.
8. **Parvatasana:** Exhale, lift the hips up and lower the head and chest downwards in an inverted 'V' posture. Keep the head between the arms and feet on the ground.



Fig. 6.10: 7. Bhujangasana, 8. Parvatasana

9. **Ashwasanchalanasana:** Inhale, bend the right leg and bring it forward. Keep the right foot on the ground between the arms and left leg backward with the knee touching the ground. Arch the spine back, look up between the eyebrows centre.

- 10. Padhastasana:** Exhale, bring the left leg forward and place the left foot beside the right foot. Place the hands on the ground by side of the feet. Try to touch the forehead to the knees without bending the knees.
- 11. Hastottanasana:** Inhale, raise both the arms up; stretch the body as much as possible and bend backwards without bending the knees.
- 12. Namaskarasana:** Exhale, come back to the original position. Slowly bring the arms down and join the palms together in front of the chest in *namaskara mudra*.

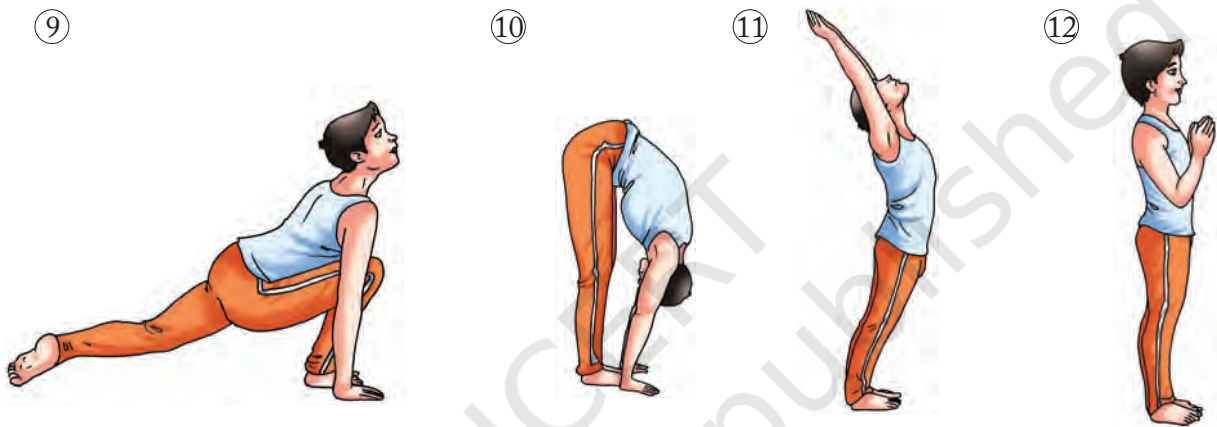

Fig. 6.11: 9. Ashwasanchalanasana, 10. Padhastasana, 11. Hastottanasana, 12. Namaskarasana

This is one round of *Surya namaskara*. Repeat the same process of twelve steps by using the other leg in fourth position (*Ashwasanchalanasana*).

Dos and Don'ts

- Perform while maintaining good physical balance.
- Perform every step with breathing pattern.
- Avoid this in case of high blood pressure, fever, slipped disc and hernia.
- Do not practise beyond one's capacity.

Benefits

- Stimulates and balances all the systems of the body.
- Increases concentration and calmness.
- Helps in curing constipation.
- Improves blood circulation all over the body, and reduces fat.
- Helps in removing carbon dioxide from the lungs replacing with fresh oxygen and improves brain function by bringing oxygenated air by blood to the brain.

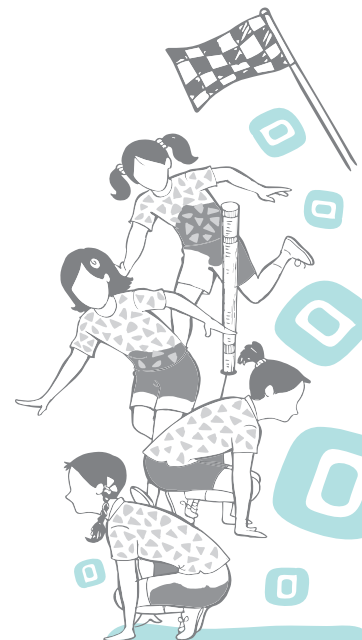

Activity 6.2

Teacher can conduct a competition between students in classroom and measure the holding time of *yogasana*.



Fig. 6.12: Tadasana



Fig. 6.13: Vrikshasana

YOGASANA

We all know that *asanas* are beneficial for our physical and mental development. Some of the *asanas* are explained here:

Tadasana

Tadasana is named after the *Tada* (Palm tree) as in the final posture, the body remains erect in standing position like a palm tree.

Stages for Practice

- Stand with your feet 2 inches apart.
- Inhale and raise your arms up to shoulder level, interlock your fingers and turn the wrist outwards.
- Raise the heels off the floor.
- Try to balance on the toes.
- While exhaling, slowly bring arms down along with the heels.
- Remove the interlock.
- Relax for a while in the standing position.

Dos and Don'ts

- Breath becomes slow and deep.
- Raise the legs slowly without any jerk.
- Avoid this practice in case of knee pain and ankle injuries.

Benefits

- This *āsana* stretches the muscles and nerves, thereby improves functioning of various systems of the body.
- The muscles become strong. It gives strength to the toes.
- It is helpful in increasing the height of young growing children. It is helpful for the patients of sciatica.

Vrikshasana

Vriksha means tree. The final position of this *asana* is a stand- still position which resembles the shape of a tree, hence the name.

Stages for Practice

- Stand with feet 2 inches apart. Focus on a point in front.
- Exhale, bend the right leg and place the foot inside the left thigh. The heel should be touched to the perineum.
- Inhale and extend the arms up and join the palms in *namaskara mudra*.
- Stay in the position for 10 to 30 seconds and breathe normally.

- Exhale and bring the arms and the right foot down. Relax and repeat the asana by bending the left leg.

Dos and Don'ts

- Normal breathing should be continued in the final posture.
- Avoid this practice in case of knee pain and ankle injuries.

Benefits

- It increases the flexibility of joints of knees and ankles and strengthens them.
- It tones up the leg muscles and rejuvenates the ligaments also.
- It helps to cure rheumatic pain and the problem of numbness.
- it improves concentration.

Padahastasana

Pāda means feet, and *hasta* means hands. Therefore, Pādahastāsana means taking the palms down towards the feet.

Stages for Practice

- Stand straight with feet 2 inches apart.
- Inhale slowly and raise the arms up.
- Stretch up the body from the waist.
- Exhale and bend forward until the trunk is parallel to the ground.
- Exhale, and bend forward until the entire palm rests on the ground near to feet.
- Maintain this final posture for 10–30 seconds.
- Now inhale, come up slowly to the vertical position and stretch the arms above the head.
- Exhale and slowly return to the starting position in reverse order.
- Relax in the standing posture.

Dos and Don'ts

- Bend from the lower back while performing *Padahastasana*.
- Bending should be according to their capacity.
- In the final stage, avoid hunch in the back.
- Avoid performing this asana in case of severe back pain.

Benefits

- It makes the spine flexible, improves digestion, and prevents constipation and menstrual problems.



Fig. 6.14: Padahastasana

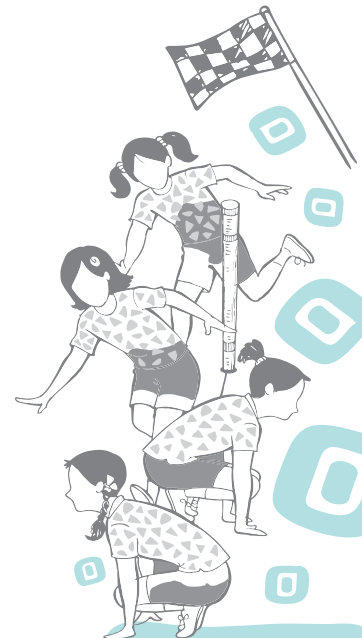

Do You Know?

Bending should always be followed by counter-bending.
Example: Performing back bending after a forward bending and vice-versa.



Fig. 6.15: Ardha Chakrasana

Activity 6.3

Students prepare a record book and write their physical and mental experiences of asanas.

- It helps to improve blood circulation in the head and heart region.
- It helps to stimulate the glands, i.e., thyroid, endocrine and pituitary gland.

Ardha Chakrasana

In Sanskrit language, *Ardha* means half and *Chakra* means wheel. In this posture, the shape of the body takes the shape of half wheel, therefore it is called *Ardha-chakrasana*.

Stages for Practice

- Stand erect on the ground with feet together.
- Keep your hands by the side. Keep your elbows parallel to each other.
- Now slowly inhale and bend backwards as much as possible.
- Try to maintain the posture with normal breathing and without losing the balance.
- Inhale and slowly come up to the original position. Relax in standing position.

Dos and Don'ts

- While bending backward, eyes should be kept open.
- Maintain the final position with the normal breath.
- Avoid this practice in case of vertigo and high BP.
- Do not bend knees in the final position.

Benefits

- This asana gives relaxation to the neck and back muscles, especially of lower back.
- It improves flexibility of the spine.
- It helps to remove fat from the waist.
- It also removes stiffness from the hip joints.
- It improves the breathing and lung capacity.

Trikonasana

Trikona means triangle. *Tri* means three and *kona* is an angle. As the *asana* resembles three arms triangle made by the trunk and the limbs, it has been named as *Trikonasana*.



Fig. 6.16: Trikonasana

Stages for Practice

- Stand on your legs 3–4 feet apart.
- Slowly raise both the arms sideways up to shoulder level.
- Turn your right foot towards the right side. Exhale, slowly bend to the right side and place the right hand just behind the right foot.
- The left arm is straight up, in line with the right arm. Turn your head and gaze at the tip of the left hand middle finger.
- Remain in the posture for 10–30 seconds with normal breathing.
- As you inhale, slowly come up. Repeat it from the left side.

Dos and Don'ts

- Bend from the waist.
- Keep the knees straight in the final position.
- Avoid bending forward while bending sideways.
- Avoid this practice in case of severe back pain.

Benefits

- Strengthens calf, thigh and waist muscles.
- Makes the spine flexible, and improves lung capacity.
- Prevents flat foot, and reduce fat.
- Kyphosis and Scoliosis patients can also do this practice.

Parshvakonasana

Parsva means side or flank and *Kona* means angle. In the final pose of this *asana*, the body forms a lateral angle, hence it is called *Parsvakonasana*.

Stages for Practice

- Stand erect.
- Inhale and spread feet approximately 3–4 feet apart. Raise the arms sideways at the shoulder level.
- Turn right foot to the right side and bend the knee, form a right angle with the thigh and calf.
- Exhale and bend from the waist to the right side and bring the right arm down, place the right palm on the floor by the inner side of the right foot.



Fig. 6.17: Parshvakonasana

Activity 6.4

Practice asanas daily for 15 days. Write your holding time in final position and analyse the improvement.

- In the final posture, spine must be kept straight and the left foot flat on the floor. Hold the posture for 30 seconds, and breathe normally.
- Inhale and come back to the starting position.
- Repeat it from the other side.

Dos and Don'ts

- In the final position, the knee of the bend leg should be in line with the heel.
- Avoid forward bend in the final posture.
- Avoid in case of severe back pain.

Benefits

- It strengthens the heart muscles.
- It improves digestion.
- It helps to reduce fat from waist and hips.
- It increases harmony between the body and mind.

Padmasana

In Sanskrit language, *Padma* means lotus. This *asana* is a traditional posture. In this *asana*, the feet look like the shape of lotus petals. That is why, it is called as *Padmasana*.



Fig. 6.18: Padmasana

Stages for Practice

- Sit on the ground.
- Fold the right leg and place the right foot above the left thigh.
- Fold the left leg and place it above the right thigh.
- Place hands on the knees in *Jnanamudra*.
- Keep the spine straight. Breathe normally.

Dos and Don'ts

- Place the foot on the opposite thigh.
- Both the knees should ideally touch the ground in the final pose.
- Avoid leaning forward.
- Avoid this practice in case of knee pain and ankle injuries.

Benefits

- Padmāsana induces mental calmness and tranquillity.
- It tones up the nerves of coccyx and sacral region by supplying them with more blood.
- It improves the digestive process and helps to relieve constipation.
- It improves the concentration and memory.
- It is helpful for people suffering from shortness of breath.

Vajrasana

Vajra means adamantine. It is believed that the body becomes like adamantine by practising it. This can be considered as a meditative posture. While practising it for meditative purposes, students should close their eyes at the final stage. This is the only posture that can be practised just after having meal.

Stages for Practice

- Sit with legs extended together, hands by the side of the body, palm resting on the ground, and fingers pointing forward. This is *dandasana*.
- Fold the right leg at the knee and place the foot under the right buttock.
- Similarly folding the left leg, place left foot under the left buttock.
- Place both the heels apart and the big toe touch and overlap each other.
- Position the buttocks in the space between the heels.
- Keep the hands on respective knees. Keep the spine erect.
- While returning to the original position, bend a little towards right side, take out your left leg and extend it.
- Similarly extend your right leg and return to the original position.

Dos and Don'ts

- Keep the knees and thighs together while sitting in *Vajrasana*.

Activity 6.5

Students should practise *Vajrasana* after dinner, daily for 15 days and write their experiences in the record book. The teacher will check it.



Fig. 6.19: Vajrasana

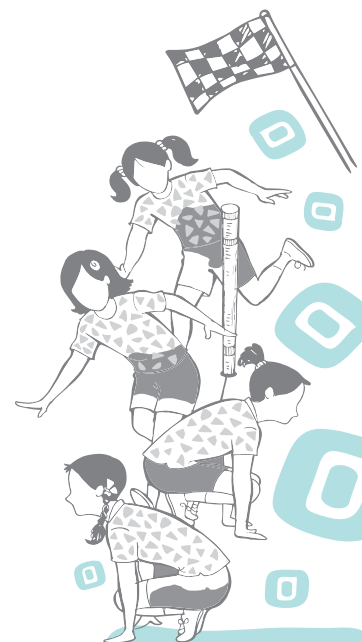

- Heels should be outside.
- Avoid excessive arching of the spine.
- Avoid this practice in case of ankle injury and knee pain.

Benefits

- This āsana strengthens thigh muscles and calf muscles.
- This āsana is good for digestion.
- It provides firm base to the spine and keeps the spine erect.
- It helps to improve concentration.

Bhadrasana

In Sanskrit language, *Bhadra* means noble. Which is the grace in the form of awakening that takes place.



Fig. 6.20: Bhadrasana

Stages for Practice

- Sit on the ground stretching both the legs together in front.
- Place your hands by the side, with palms resting on the ground.
- Fingers should remain together pointing forward. This is *dandasana*.
- Fold the legs slowly at knees; and join both the soles with each other.
- Hold the ankles.
- Slowly bring the heels towards perineum.
- The knees should touch the ground. Head, neck and back should be straight.
- Maintain the final position for 20–30 seconds.
- Come back in *dandasana* and relax.

Dos and Don'ts

- Spine should be kept straight.
- Knees should be touched to the ground.
- Avoid excessive arching of the spine.
- One should avoid pushing the foot inside beyond one's capacity.

Benefits

- This asana is good for lumber region and keeps it healthy.
- It is beneficial in women's physical problems and facilitates easy child birth.
- It helps in improving concentration.
- It calms down the mind.

Ushtrasana

Ushtra means camel. The body in this posture resembles the posture of a camel, hence the name.



Fig. 6.21: Ushtrasana

Stages for Practice

- Sit in *Vajrasana*.
- Kneel down on the floor. Keep your thighs and feet 2–3 inches apart, toes pointing back and resting on the floor.
- While inhaling bend backward. Be careful not to jerk the body while bending backwards.
- With exhalation place the right palm on the right heel and left palm on the left heel.

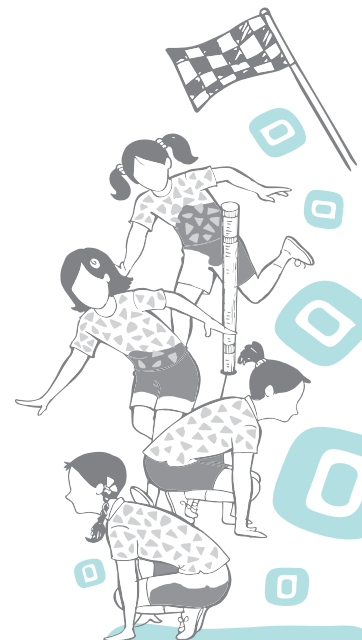

- In final position, thighs will be vertical to the floor and the head tilted backwards.
- Weight of the body should be evenly supported by the arms and legs.
- Inhale, slowly come back to normal position and relax in *Vajrasana*.

Dos and Don'ts

- Keep the thighs vertical to the ground.
- Avoid jerking the body while bending backward.
- Avoid in case of hernia, vertigo, and frozen shoulder.
- Proceeding to the final stage of asana should be gradual.

Benefits

- This is useful in back pain and neck pain.
- It helps to reduce fat over the abdomen and hips.
- It helps to strengthen the back muscles and leg muscles.
- It is beneficial in respiratory disorders.

Shashankasana

Shashanka means rabbit. The body in this posture takes the shape of a rabbit, hence the name.



Fig. 6.22: *Shashankasana*

Stages for Practice

- Sit in *Vajrasana*. Keep the spine erect.
- Spread both the knees wide apart with the toes remaining together.
- Place the palms between the knees.
- Exhaling, bend forward from the waist with the arms straight.

- Chin and chest should be resting on the floor.
- Look in front and maintain the position.
- Inhale and come back in *Vajrasana*.

Dos and Don'ts

- Keep the back straight in the final pose.
- Don't raise hips while practising this asana.

Benefits

- It tones up the reproductive organs.
- It strengthens the abdominal and pelvic region.
- This āsana relieves sciatica nerve.
- It helps to reduce stress, anger, etc.

Uttanamandukasana

Uttana means upright and *Manduka* means frog. The final position of *Uttanamandukasana* resembles an upright frog, hence the name. In the final posture, the head is held by the elbows.



Fig. 6.23: Uttanamandukasana

Stages for Practice

- Sit in *Vajrasana*.
- Spread both the knees wide apart with the toes remaining together.
- Raise your right arm, fold it and take it backward from above the right shoulder and place the palm below the left shoulder.
- Now fold the left arm similarly and place the palm below the right shoulder.

Activity 6.6

Teacher should check the interest of students in this *asana*. The teacher can check the perfection of students and motivate them.

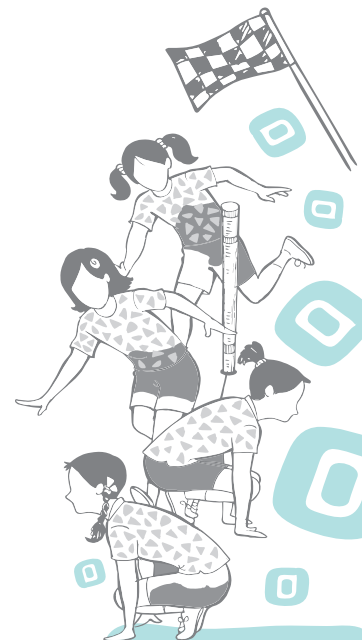

- Maintain the position.
- While coming back, slowly remove the left arm and then right arm, bring the knees together as in the initial position.
- Relax in *Vajrasana*.

Dos and Don'ts

- Spread the knees well.
- Keep the back and neck straight in the final position.
- Avoid the gap between thighs and ground.

Benefits

- This asana is helpful in back ache and neck pain.
- It helps in improving the diaphragmatic movements.
- It improves the lung capacity.

Paschimottanasana

Paśchima means back and *Uttān* means stretch out. In this āsana, the back side of the body including the spinal column gets stretched, hence the name.



Fig. 6.24: *Paschimottanasana*

Stages for Practice

- Sit in *Dandasana*. Inhale and raise your arms up. Stretch your back and bend forward as much as possible.
- Hold the toes and place the elbows by the side, on the ground.
- Maintain the posture as per the capacity. Come back by raising hands and head in the initial position.

Dos and Don'ts

- Keep the knees straight. Normal breathing should continue.
- Avoid hunch in the back.
- Avoid the practice in case of severe back pain.



Benefits

- It stimulates the function of abdominal organs, and improves digestion.
- It is helpful in removing constipation, obesity, dyspepsia and seminal weakness.
- It helps to improve blood circulation and regulates blood pressure and reduce fat.
- It improves the flexibility of spine.

Suptavajrasana

Suptavajrasana is further development of *Vajrasana*. *Suptavajrasana* means lying in *Vajrasana*; hence, it is named *Suptavajrasana*.

Stages for Practice

- Sit in *Vajrasana*. Slowly bend backwards taking the support of the hand; and place elbows on the ground.
- Slowly straighten the hands and completely lie on the back with shoulders resting on the ground and knees remaining together.
- Beginners may keep their hands on respective thighs.
- After practising this position well, stretch the arms behind and hold the elbow/arm with the hand of another arm.
- While returning to the original position, first take out your hands and place them by the sides of your body.
- Now, with the help of elbows come back to the initial position.



Fig. 6.25: Suptavajrasana

Dos and Don'ts

- With the support of hand, come in supine position.
- Keep the knees together in final position.
- Do not strain in knees and thigh muscles.
- Avoid the practice in case of knee pain.

Do You Know?

This asana is also performed with another state, where hands are kept upright with elbows resting on ground and face rests in between both palms while looking forward.

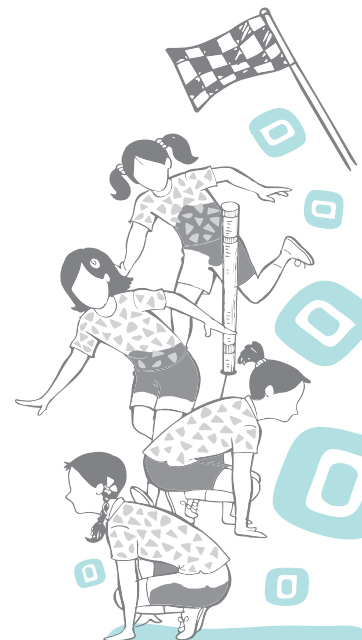

Benefits

- This asana strengthens the abdominal muscles.
- It is useful in the management of high blood pressure and sciatica.
- It is a good remedy for constipation and backache.
- It improves blood circulation and calmness.

Vakrasana

Vakra means twisted. In this āsana, the spine is twisted; due to this reason, this asana is called *Vakrasana*.

Stages for Practice

- Sit in *dandasana*.
- Bend the right leg, and place the right foot beside the left knee.
- As you exhale, twist the body to the right.
- Bring the left arm around the right knee and clasp the right big toe or place the palm beside the right foot.
- Take the right arm back and keep the palm on the ground with the back straight.
- Remain in the posture for 10–30 seconds with normal breathing and relax.
- Take out your hands with exhalation and relax.
- Repeat the same procedure on the other side.



Fig. 6.26: Vakrasana

Dos and Don'ts

- Perform within physical limits. Do not strain the body unnecessarily.
- Avoid the practice in case of knee pain, hernia and organ displacement.

Benefits

- This asana massage abdominal muscles.
- It is useful in the management of high blood pressure and sciatica.
- It is a good remedy for constipation, diabetics, back ache and improves blood circulation.
- It helps in calmness of mind.
- Enhances lung capacity.

Ardhamatsyendrasana

Ardhamatsyendrasana is named after the great yogi Matsyendranātha. Full version of this asana is very difficult for a beginner to master it. Therefore, it has been modified. This modified version is called *Ardhamatsyendrasana*. Matsyendra is the name of a *Hatha* yogi it is said that he attained *siddhi* in this asana, so the full version of this asana is known as *Matsyendrasana*.

Stages for Practice

- Sit on the ground in *dandasana*. Bend the left leg, then place the left heel on the side of the right hip.
- Place right foot near the left knee, on the ground.
- Place left arm over the right knee and grasp the toes of right foot with the left hand.
- Take right arm behind the back around the waist.
- Turn your head towards the right side and try to look behind.
- Repeat it from the opposite side.

Dos and Don'ts

- Keep the balance of body on the hips.
- Place the bend knee behind the armpit of the opposite arm.
- Avoid the practice in case of severe back pain, vertebral and disc disorders.
- Avoid the jerking movement in the twisting of back.
- Do not lean forward or backward.

Benefits

- This āsana is good for the stimulation of pancreas, adrenal glands, kidneys, liver and spleen.
- It helps to relieve constipation, asthma, indigestion, diabetics and obesity.
- It strengthens muscles of the spine and back and makes them flexible.
- It corrects stooping shoulders, a bent back and the defective posture.



Fig. 6.27: Ardhamatsyendrasana

Activity 6.7

Teacher conducts class competition and appreciates the better students.

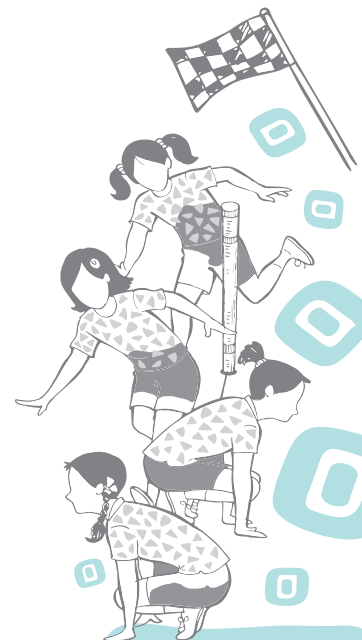



Fig. 6.28: Gomukhasana

- It stretches and strengthens the shoulders, hips and neck.
- It is good for diabetic patients.

Gomukhasana

In Sanskrit language, 'Gomukha' means 'cow's face'. In this āsana, the leg's position takes the shape of *Gomukha*, hence the name *Gomukhāsana*.

Stages for Practice

- Sit in *Dandasana*.
- Fold left leg from the knee and place it on the ground by the side of right buttock.
- Similarly fold right leg from the knee, bring it over left leg and place right heel by the left buttock.
- Raise the left arm, bend it at the elbow and take it below the shoulders towards the back.
- Raise the right arm, bend it at elbow and take it upward and behind the back.
- Interlock the fingers of both the hands behind the back.
- Keep the head straight.
- Gaze in front and maintain normal breathing.
- Stay in this position for as long as comfortable and then return to the original position, step by step.
- Repeat the same by changing the position of the legs and hands.

Dos and Don'ts

- Avoid sitting on the heels.
- Avoid the practice in case of shoulder, neck and knee pain.
- Keep the neck straight in the final position.
- The above elbow should be closed to the ear.

Expected Learning Outcomes

- The practice of this asana strengthens muscles of the back and biceps.
- It removes the pain in hip and lower extremities.
- It helps in making the spine straight.
- This āsana is very useful in arthritis and dry piles.
- It is useful in frozen shoulders, neck pain and cervical spondylitis.
- It gives good exercise to the lungs and helps in respiratory diseases.



Makrasana

In Sanskrit *Makara* means crocodile. In this āsana, the body resembles a crocodile, hence the name.

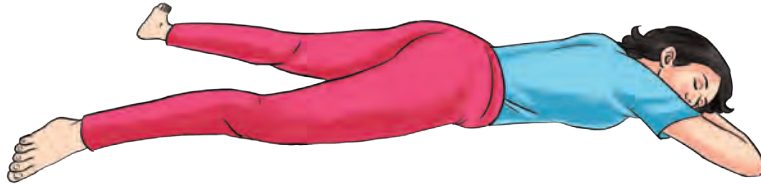

Fig. 6.29: Makrasana

Stages for Practice

- Lie on the abdomen (prone lying position), with arms beside your body.
- Spread the legs little apart (1–2 feet) and place them comfortably on the ground in such a position that the heels face each other and toes point outwards.
- Fold the arms at elbows. Place palm on the palm with the head/face relaxing on the palms.
- Slowly close eyes and relax. Do normal breathing and remain in this position as long as comfortable.

Dos and Don'ts

- Place both feet apart and keep the heels towards each other.
- Avoid this practice in case of heart problems.

Benefits

- It is good for asthma, dyspepsia and *vata* diseases.
- It is helpful in relaxing.
- Removes mental and physical fatigue.
- It reduces anxiety.

Bhujangasana

'*Bhujanga*' means cobra. The final position of this āsana resembles the shape of a cobra. Hence it is named as *Bhujangasana*.



Fig. 6.30: Bhujangasana

Activity 6.8

Prepare a list of asanas useful for relaxing the body.

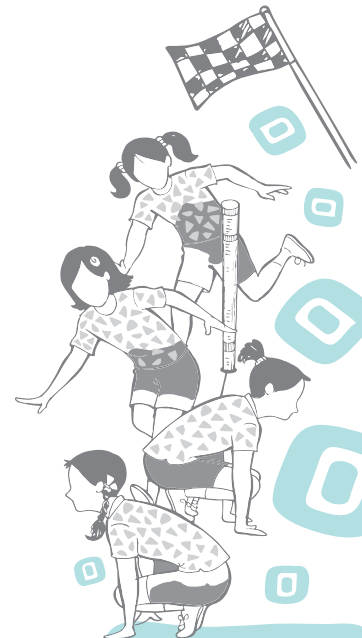

Stages for Practice

- Lie down in the prone position.
- Join the feet and bend the arms at the elbow, place the palms near the chest on the floor.
- Slowly raise the head, neck and shoulders. Raise the trunk up to the navel.
- Maintain the posture for as long as comfortable. Then slowly bring the body down on the ground.
- Relax in *makrasana*.

Dos and Don'ts

- Keep the elbows parallel to each other and pointed upward.
- Normal breathing should be continued.
- Avoid this practice in case of hernia and abdominal injuries.
- Do not raise body below the navel.
- Do not straighten your elbows and move slowly.

Benefits

- This is good for stress management.
- It is beneficial for relieving flatulence after meals.
- It can relocate the slipped disc, removes backache and keeps the spine supple and healthy.
- It tones the ovaries and uterus, and helps alleviate menstrual and other gynaecological disorders.
- It improves the lung capacity.

Activity 6.9

Students practice *Shalabhasana* daily and maintain in the record book. Teacher will check the improvement in holding time.

Shalabhasana

The meaning of *salabha* is locust. In the final position of this āsana, body resembles the shape of a locust, hence the name.

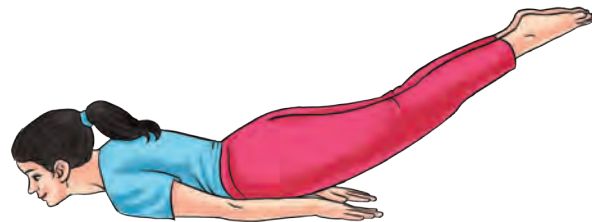

Fig. 6.31: Shalabhasana

Stages for Practice

- Lie down in prone position, place the palms below the thighs, press them downward and join the heels.
- Chin should be placed on the ground.

- Lift the legs as high as possible while inhaling.
- Bring down the legs while exhaling.
- Release the hands.
- Relax in *makrasana*.

Dos and Don'ts

- Raise the legs slowly without jerks.
- Take the support of the hand to raise the legs.
- Place the chin on the ground.
- Keep the knees straight in the final position.
- Avoid bending the knees.
- Avoid keeping distance between the knees.
- Avoid bending at the elbows.
- Do not practice it beyond one's physical limits/capacity.

Benefits

- *Shalabhasana* stimulates the autonomous nervous system particularly the parasympathetic one.
- It massages abdominal organs.
- It is good for lower back ache and slipdisk.
- It relieves constipation and improves digestion.
- It improves blood circulation and directs blood circulation upwards.



Fig. 6.32: Pawanmuktasana

Pawanmuktasana

'Pawana' means wind and 'mukta' means released. As the name suggests, the practice of this *asana* helps in releasing excessive gas from the body. This *asana* when performed with one leg, is called *Ekapada Pawanamuktasana*.

Stages for Practice

- Lift both legs, bend them at the knees and encircle the knees with both arms. Press the knees and bring them towards the chest.
- Raise the head with the chin touching the knees. This is *Pawanamuktasana*.

Dos and Don'ts

- Press the knees to the chest.
- Toes should be relaxed.
- Avoid raising beyond the mid-torso.
- Perform within physical limits.
- Avoid this practice in case of Cervical Spondylitis.

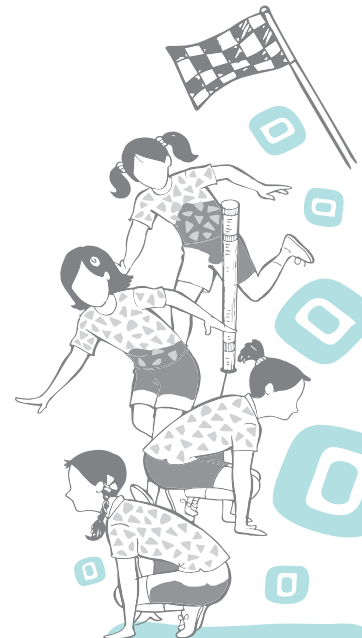

Benefits

- The practice of this āsana helps in eliminating toxic gases from the abdomen.
- This āsana relieves constipation and the feeling of heaviness in the stomach.
- Extra fat in the abdominal area gets dissolved. It also reduces abdominal fat.
- The spine becomes flexible.
- Improves blood circulation.

Setubandhasana

Setubandha means formation of bridge. The body in this posture is positioned like a bridge. *Setu* means bridge, and *bandha* means to bind. In this *asana*, body imitates a bridge structure.



Fig. 6.33: Setubandhasana

Stages for Practice

- Bend both the legs at the knees and bring the heels near the buttocks.
- While holding both the ankles, firmly keep the knees and feet in one straight line. Separation between legs should be same as the distance between shoulders.
- Inhale, slowly raise your buttocks and trunk up as much as you can to form a bridge.
- Remain in this position for 10–30 seconds, with normal breathing.
- Exhale, slowly return to the original position and relax in *Shavasana*.

Dos and Don'ts

- Keep the feet near the buttocks.
- Keep the knees vertical to the ground.
- Avoid giving any jerk to the body in the final position.
- Avoid this practice in case of Cervical Spondylitis.



Benefits

- It removes strain on the back.
- It stretches and massages the colon and other abdominal organs.
- It helps to improve lung capacity.
- It provides strength to the back muscles.
- Brings flexibility to the spine.

Viparitkarani

According to Sanskrit, *Viparita* means 'opposite' and *Karani* means 'doing', 'by which'. In this āsana, the state of body is opposite (head downwards and legs upwards) to the normal. That's how the asana derived its name as *Vipritasana*.

Stages for Practice

- Lie in relaxed supine position with the legs together.
- Raise the legs up, keeping them straight.
- Push down on the arms and hands and raise the buttock.
- Support the lower back with hands, keeping elbows on the floor.
- Remain steady for a while with normal breathing.
- Release the position and relax on the back.

Dos and Don'ts

- Keep the balance of the body on elbows.
- Keep the knees straight.
- Avoid practising this posture immediately after any violent exercise.
- Avoid this practice in case of heart problems.

Benefits

- Its regular practice improves digestion, stimulates appetite and helps in relieving constipation.
- This practice improves blood circulation to the brain.
- It brings the luster to the skin.
- It balances functioning of the thyroid, parathyroid, and thymus glands.
- It also helps in the management of insomnia, varicose veins, and hernia.

Shavasana

In Sanskrit, *Shava* means dead body. The posture is called *Savasana* as the body in this *asana* resembles a dead body.

Activity 6.10

- Students will share their own experiences with their friends and make a comparative report.
- Teacher can conduct competition between yoga practitioner and non yoga practitioner students and motivate them for doing better.

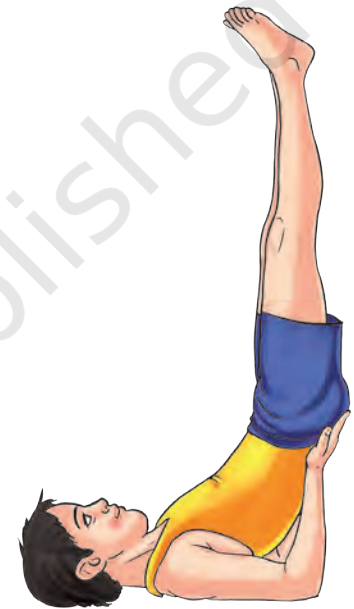

Fig. 6.34: Viparitkarani

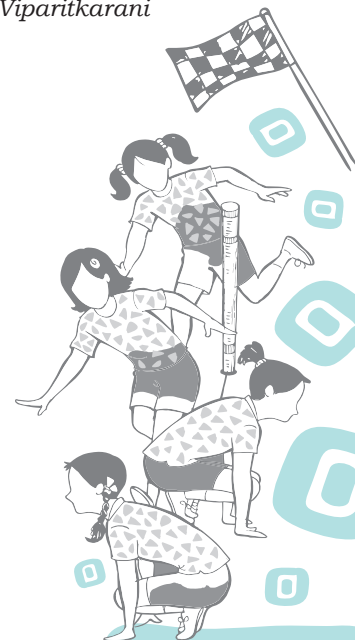



Fig. 6.35: Shavasana

Stages for Practice

- Lie down on the back with the hands comfortably away from the body.
- Make a distance of one to two feet between the feet with toes pointing outward.
- Place both the hands on the ground, 10 inches away from the body with fingers in a semi-flexed position and palms facing upwards.
- Keep the head in the most convenient position.
- Gently close the eyes, breathe normally or practise moderately deep abdominal breathing.
- Attend to the flow of the breath without moving the body.
- Become aware of the natural breath and allow it to become rhythmic and slow.
- Try to relax all parts of the body by diffusing tension in each part of the body.

Dos and Don'ts

- Relax the whole body.
- Back should be relaxed.
- Avoid the tightness in any part of the body.

Benefits

- It helps to reduce stress and removes physical and mental fatigue.
- It relaxes all muscles and nerves of the body.
- It is helpful to overcome the psychological disorders.
- It is very beneficial for managing high blood pressure, cardiac diseases, and stress and anxiety disorders.

PRANAYAMA

Prana refers to the 'vital force' and *ayama* means to restraint. *Prana* is the vital energy without which the body would not survive. *Pranayama* is a breathing technique by which breath regulates and controls the *prana*. It helps to improve



the control over autonomic respiratory mechanisms through breathing patterns that generate energy and enhance emotional stability. Some of the breathing practices are mentioned here.

Phases of *Pranayama*: *Puraka*, *Rechaka* and *Kumbhaka*

- ***Puraka***: In *puraka*, inhalation is very gentle and deep with full awareness. This helps the chest to expand more in its clavicular (upper) region, coastal (middle and lower) region, from front to back and also sideways. This expansion creates more inner space allowing more inflow of air into lungs. At the same time, diaphragm contracts more and moves down towards abdominal cavity to the maximum. In this process, muscles of the front wall in abdominal cavity and the perineal region are under pressure to move outwards and downwards respectively.
- ***Kumbhaka*** means retention of breath inside or outside. *Kumbhaka* performed along with bandhas (*Mulabandha*, *Uddiyanabandha* and *Jalandharbandha*) helps in the process of metabolism and assists in more efficient exchange of oxygen and carbon dioxide. Through regulated breathing, *Kumbhaka* ensures sufficient supply of oxygen and thus helps the brain to work efficiently.
- ***Rechaka***: *Rechaka* assists in more efficient releasing of carbon dioxide. The duration of *rechaka* is supposed to be double of *puraka*. The process of *rechaka* starts at the end of *kumbhaka*, when *bandhas* are released. In the process of *rechaka*, diaphragm is pushed upwards towards the cavity of chest making the chest to contract. Slow and prolonged exhalation prescribed for *rechaka* helps in completely pushing the carbon dioxide out of lungs.

Yogic Deep Breathing

There are three types of breathing:

- Abdominal
- Thoracic
- Clavicular

Combination of all three types of breathing becomes yogic deep breathing.

Technique

1. Sit in a comfortable posture.

Activity 6.11

Students can check their breath holding time and maintain a record book (mentioning the time of hold) to collect one month data with of their physical and mental experiences.

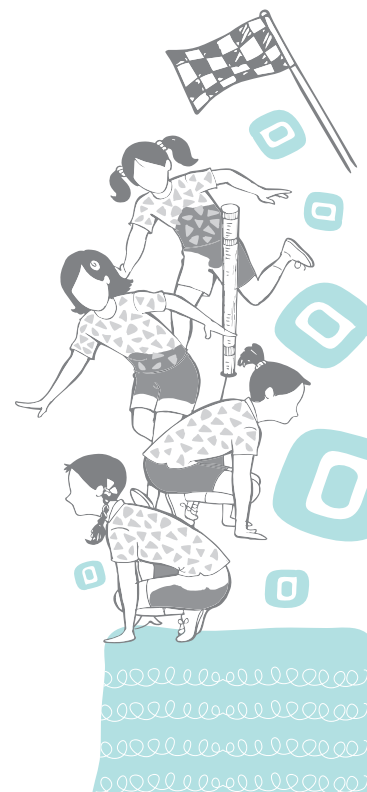

2. **Inhale:** Deep, slow and long intake of oxygen with the combination of three types of breathing. (During inhalation, first the abdomen comes out and diaphragm has tensed moves the chest cavity outward and upward and in the last air fills clavicular region (collar bone) and it moves upward.
3. **Exhale:** Repeat the whole procedure in reverse manner.
4. Repeat the same practice four to five times.

Nadishodhana Pranayama

Nadishodhana means to purify the *nadis*. *Nadishodhana pranayama* is also known as *anuloma-viloma*. *Viloma* means produced in the reverse order. This variety gets its name from the fact that the nostrils are alternatively used during each inhalation and exhalation in this *pranayama*.

Stages for Practice

- Sit in any comfortable meditative posture.
- Keep the head and spine erect.
- Close the eyes.
- Pay attention to the breath.
- Place the hands on their respective knees.
- Adopt *nasagran mudra* of the right hand and *jnana mudra* of the left hand.
- Close the right nostril with the thumb.
- Inhale through the left nostril and exhale through the right nostril, keeping the respiration rate slow, deep and silent.
- Inhale through the right nostril again.
- Exhale through the left nostril, keeping the respiration rate slow, deep and silent.



Fig. 6.36: *Nadishodhana pranayama*



Dos and Don'ts

- Keep the ratio of 1:1 between inhalation and exhalation.
- Avoid producing any sound from the nose.
- Avoid pressing hard on the nostrils.

Benefits

- Calms and steadies the mind, improves focus and concentration.
- Improves blood supply to the brain.
- Balances the left and right hemispheres and promotes clear thinking.
- Benefits in following conditions—asthma, allergies, high or low blood pressure, stress-related heart conditions, hyperactivity, insomnia, chronic pain, endocrine imbalances and psychological conditions as anxiety, stress, etc.

Ujjayi Pranayama**Stages for Practice**

- Sit in *padmasana* or *siddhasana*.
- Close the mouth. Contract the region at the back of the throat, inhale slowly through both the nostrils in smooth and uniform manner till the breath fills the space from the throat to the heart.
- During inhalation, a peculiar sound is produced owing to the partial closing of glottis.
- This sound should be of mild and uniform pitch.
- It should be continuous also.
- Expand the chest while inhaling.
- Slowly exhale through the left nostril.



Fig. 6.37: Ujjayi pranayama

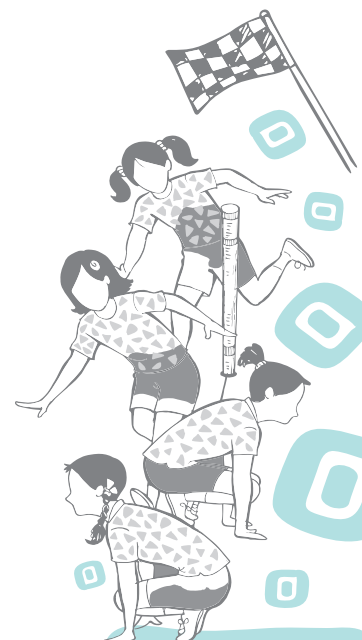

Dos and Don'ts

- Breathing should be deep, slow and long.
- Do not make harsh sound during inhalation.

Benefits

- *Ujjayi pranayama* removes heat from the head and keeps it cool.
- It removes phlegm in the throat and prevents all sorts of pulmonary diseases.
- It prevents diseases caused by deficient inhalation of oxygen and cardiac diseases.
- Regular practice of this *pranayama* defends the practitioner from diseases of phlegm, degeneration, dyspepsia, dysentery, enlarged spleen, cough or fever.

BANDHAS

Bandhas means to hold or lock. *Bandhas* may be introduced during the practice of *mudra* and *pranayama*.

Jalandhara Bandha

Jalandhara bandha is performed by contracting the throat and bringing the chin to the chest while retaining the breath.



Fig. 6.38: Jalandhara bandha

Stages for Practice

- Sit comfortably in *Padmasana* or *Siddhasana*.
- Place both the hands (palms) on the knees in *jnana mudra*.
- Allow the whole body to relax.
- Inhale slowly and deeply and retain the breath.

- Lower the chin down in front and set it against the jugular notch or the sternum notch and close the eyes.
- Hold the breath according to capability.
- Raise the head slowly and release the *bandha*.
- Exhale deeply.

Dos and Don'ts

- Keep the back straight
- Avoid jerky movement of the neck.
- Avoid this practice in case of heart diseases and cervical spondylitis.

Benefits

- This practice improves the functioning of thyroid gland and helps in curing the ailments of throat.
- It enhances the process of exchange of gases during the retention of breath.

Uddiyana Bandha

The word '*Uddiyana*' comes from '*ud*' and '*di*', which means to fly up or to rise up. Through this *bandha*, *prana* like a bird flies up incessantly, hence it is called *uddiyanabandha*.

Stages for Practice

- Sit comfortably in *Siddhasana* or *Padmasana*.
- Place both the hands (palms) on the knees firmly.
- Exhale completely through mouth and hold the breath out.
- Pull abdominal muscles up and inside towards the spine. This is *Uddiyana Bandha*.
- Retain the breath outside as long as one feels comfortable.
- Raise the head, inhale slowly and release the abdominal muscles.
- Return to the normal position.

Dos and Don'ts

- Pull the abdominal muscles after exhalation.
- Avoid holding the breath beyond limit.
- Avoid in case of heart diseases.

Benefits

- *Uddiyana Bandha* improves blood circulation and strengthens all the internal organs.
- All the abdominal organs get toned, massaged and strengthened.

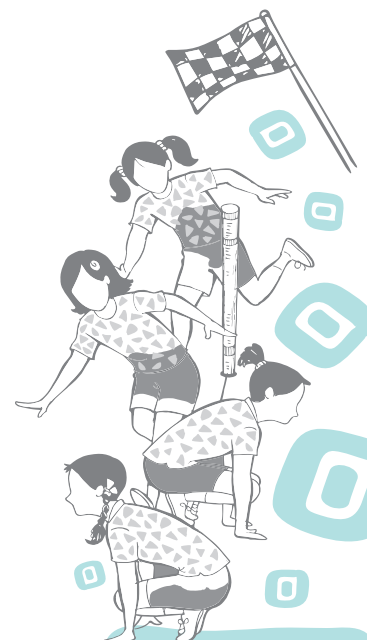

Do You Know?

Dhyana can activate our sixth sense.

Activity 6.12

Practice meditation for five to ten minutes daily and prepare an experience report on the changes that you feel after 15 days.



Fig. 6.39: Dhyana

- It helps in improving the digestion process.
- It enhances the lung capacity.

DHYANA

Dhyana is a part of *Astanga yoga*. It is related to the practice of mind and is the gateway to inner world. One can enter and into *dhyana* stage after the practice of *shatkarma*, *asana*, *pranayama*. They involve controlling the mind to finally transcend the mind. It helps to improve the concentration and emotional stability and improves the functioning of mental activities.

There are several methods to practice *dhyana*. All the practices of *dhyana* are to be focussed on a single point either a *mantra* or an object.

Process of Dhyana

- Sit in any meditative posture.
- Place hands in *Jnana mudra* on the knees.
- Spine should be straight and relaxed with closed eyes.
- Now focus on breathing.
- Observe inhalation and exhalation.
- Maintain the process for 5–7 minutes.
- Slowly bring awareness back to the surroundings.
- Gently rub the palms together and place them on eyes.
- After few seconds remove palms and open eyes.

This is the practice of breath awareness. One can practice it by focussing on different things, i.e., any object in between eyebrow center, any sound, etc.

Meditation or *Dhyana* activates the parasympathetic nervous system which provides the relaxation of body and mind.

- It helps in controlling the blood pressure.
- It normalises the heart rate.
- It helps to calm down all the mental activities.
- It reduces anxiety.



ASSESSMENT

I. Long Answer Questions

1. Write the meaning of yoga and its relevance in day-to-day life.
2. Write about the history and development of yoga.
3. Mention the guiding principles of yoga.
4. Write the role of *asana* in wellness.
5. Write the role of *pranayama* in wellness.
6. Write the role of *shodhana a kriyas* in wellness.
7. What is *kapalbhati*? Write its technique and benefits.
8. Explain the concept of *puraka, rechaka, and kumbhaka*.
9. Write the benefits of *dhyana*.

II. Short Answer Questions

1. What is *Karma* yoga?
2. What is *Jnana* yoga?
3. What is *Raja* yoga?
4. Write the types of *neti*.
5. Write the name of yogic practices.
6. Write the root word of yoga.
7. How many poses are present in *surya namaskara*?
8. *Nath* culture is related to which school of yoga?
9. *Ashtanga* yoga is related to which school of yoga?
10. What is *Nishkam karma*?
11. What is *Navdabhakti*?
12. What is *Vihara*?
13. Which system is related to *pranayama*?
14. Name the practice which cleanse our nasal passage.

III. Fill in the Blanks

1. *Vedas* have _____ types.
2. *Uddiyana bandha* is related to _____ region.
3. *Jalandhara bandha* is related to _____ region.
4. In *Kapalbhati*, the meaning of *kapal* is _____.



IV. State whether True or False

1. *Ujjayi* is a practice of *asana*.
2. *Surya Namaskar* is a process of 12 *asanas*.
3. *Agnisar* is related to water element of body.
4. *Jnana Yoga* is a path of devotion.
5. *Kapalbhati* is a *pranayama*.





11152CH07

SAFETY AND SECURITY



Games and sports are important for the development of physical, emotional, mental and social health. While playing any games and sports, safety and security of children is very important. It is also necessary to take steps to prevent injuries in sports field during competitions or sports training. In this chapter, we are discussing safety issues regarding the sports facilities and also dealing with the health hazards related to alcohol and substance abuse, including common medicines.

SAFETY MEASURES IN PLAYGROUNDS, GYMNASIUM AND SWIMMING POOL

In the present scenario of competition in games and sports, coaches and athletes are mostly concerned with the winning spirit and hard but systematic sports training. During sports training and competitions of various games, safety measures and security of players need to be kept in mind. Injuries during sports training lead to fearful emotional or psychological phobia. To save the players from such phobia, simple safety rules and measures should be applied. These safety rules are to be observed by the physical education teachers, sports trainers, coaches, school administrators as well as sports equipment manufacturers. Besides these, students who are taking part in technical sports such as gymnastics and swimming, and self-defense activities shall also be taught to avoid injuries and observe safety measures during sports training. These safety measures may be applied in the following steps:

Safety regarding Sports Facilities

One of the most important safety measures which shall be kept in mind is regarding the sports ground, sports instruments and sports uniform.

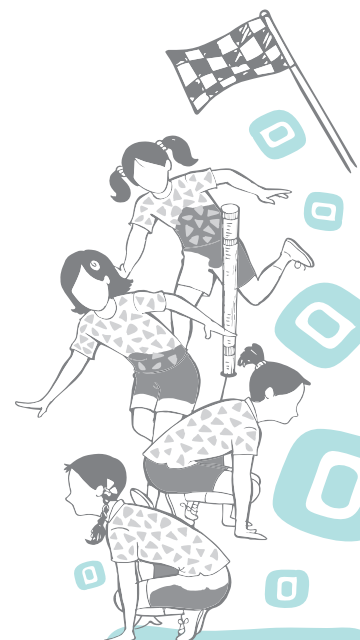

Do You Know?

Due to decreasing land and forest ratio, cutting or eliminating trees is not permissible.

Sports ground

While preparing sports ground, the construction company should try to remove all the possible hazards such as nearby high tension electric line, barbed wire, bushes or wild grass bushes, close wall with hard surface and shifting of trees. The surface of the ground should be safe and clean, free from hazardous material like stone, broken bricks, etc. Wherever possible, the construction of hard surfaces for games like basketball, badminton and tennis should be built up properly with proper space. The chain link fencing or stairs for accommodating trainers, coaches and players or spectators should be away from the playing area, probably 6 meters away from the end lines of the play field.

Field

Proper and separate sitting area for extra players of the participating teams shall also be provided to avoid the mixing of players. Playing area of sports should be sufficient enough to prevent accidental injuries. Sitting area for spectators should be away from the actual playing area to avoid any untoward incident during competitions. Playing area should be clean and away from the hazardous materials/objects. Trees and bushes should be shifted from the play field to avoid collision. Sufficient warming up area away from the competition arena may be provided. Dangerous broken glass material or sharp edged stones should also be removed from the playing area to avoid potential injury.

Safety regarding sports instruments

Due to sports engineering and technological advancement, modern sports are played with sports equipment which are performance friendly and add technical support during movements. During planning and organising of sports equipment, the manufactures shall add the 'concept of safety to sportsperson' as priority. The material used for manufacturing the instrument/equipment shall be of high standard as the sportsperson is highly dependent on them for performing their skills. Players are also advised not to use the damaged equipment/instruments to avoid accidents. Efforts should be made that the playing surface of different games and sports should be constructed separately as advised by the respective officials, federations or associations, if space is available.

Safety regarding uniforms

Sports uniform adds glamour and advantage to the performance in games and sports but poor fabric and non-



suitable shoes may be painful to the players. Sports uniforms play an important role to prepare the mood of sportspersons, as it helps the players to feel better. Preparation of sportspersons for competition includes selection of—

- a) Types of shoes
- b) Fabric of the T-shirt and its colour
- c) Selection of the shoe — Most of the novice players do not know how to select the shoe for sports training, as they are not aware of the injuries caused by the poorly manufactured shoes. Generally the defect is either in the material or the arch of the sole. The defection arch may not provide support to the foot resulting in unbalanced body weight. In some cases, it has been noticed that the lack of proper arch support in the shoes may cause stress in the legs that leads to muscles stiffness. Ultimately the sportsperson gets tired and may rupture leg muscles if the activity is not done with proper shoes. The objective of wearing properly manufactured shoes are:
 - (i) comfortable feeling
 - (ii) proper ankle support
 - (iii) proper balance
 - (iv) avoiding leg injury due to uncomfortable shoes
- d. Fabric of the T-shirt: T-shirt and its colour are important for the players, especially for the novice. Due to weather variations in India, a light colored fabric which does not absorb sweat is considered better. Fabric which consumes sweat may cause allergy and skin problem if it remains in contact with the body for longer duration.

Safety measures in relation to Gymnasium

Gymnasium in any institution is used for sports training for multiple sports. It is considered as an asset to the institute, and students often visit the gymnasium for the purpose of building their body, rehabilitation after injury as well as to get into proper shape. Injury in gymnasium may take place due to the following:

- a) Unsafe method of keeping equipment
- b) Lack of proper place for exercises
- c) Lack of warm-up area
- d) Old equipment
- e) Unsafe fitting of electrical gadgets

Do You Know?

The game of Kabaddi and Kho-Kho in modern time is played on synthetic surface. Usually indoor synthetic surfaces are less vulnerable to injuries.

Activity 7.1

- Collect information about the safety measures taken in your school building play field/indoor hall and equipment.
- Discuss with teacher.

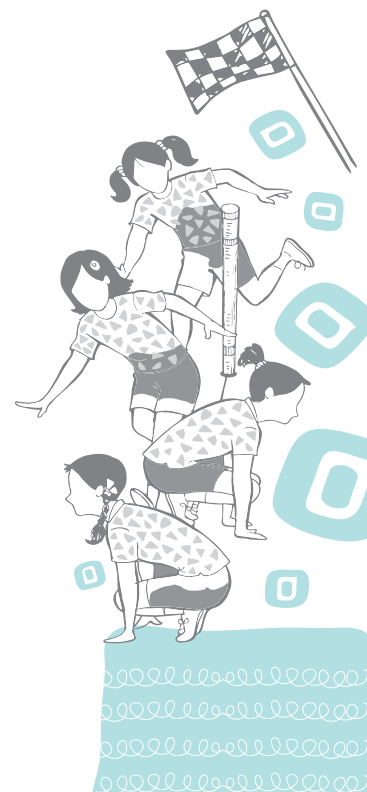

- f) Uncleaned surface
- g) Slippery gymnasium surface
- h) Poor lighting conditions
- i) Poor sanitation and lack of water supply
- j) Not observing safety measures during lifting and keeping the weight barbells
- k) Lack of proper knowledge of using equipment

Safety measures in relation to swimming pool

The schools or institutions having swimming pool need to operate it with proper safety measures. To observe safety rules in swimming pool, there shall be instructors, assistant coaches, life guards, gatekeeper and sweepers. Availability of human power, water quality and cleanliness of the swimming pool are very important aspects of safety measures. The following steps should be taken for safe and hygienic pool conditions:

- a) There should be separate swimming pool for the beginners and the advance swimmers.
- b) Students should avoid going into the deeper side of the swimming pool without proper safety measures.
- c) Life guards should be well trained and careful during the pool activity. Special attention should be paid for the swimming and diving activities towards the deep end of the pool.
- d) Swimming pool instructors/coaches and life guards should be well equipped with life saving devices such as, long stick, rope, whistle, lifesaving jackets, swimming pads and kicking boards, etc.
- e) Students should follow proper instructions and guidelines of swimming pool for safety measures as well as to avoid injuries.
- f) Proper swimming uniform like costume, cap and eye protector must be used regularly during swimming in the pool.
- g) Water treatment plant must be operational during the swimming activities of the students.
- h) Chlorination of water through proper amount of chlorine will be helpful in removing accumulated algae from the water.
- i) Surface of the swimming pool should be cleaned regularly with the help of suction head brushing machine.
- j) Swimming activities should be allowed only in the presence of life guards.



- k) While constructing the surface of pool, smooth finishing and use of standard chemicals may be ensured.
- l) Safety stairs and hangers in the pool will help swimmers to enter in the pool.
- m) Showers at pool side with fresh water taps should also be facilitated for pre and post swim showers.
- n) The surface of washrooms in swimming pool site should be supported through matting to avoid injury from the slippery surface.
- o) Proper lighting in the pool is always useful particularly in the evening for supervising swimmers inside the pool.

SAFETY MEASURES TO PREVENT INJURIES

It is always said that 'prevention is better than cure'. Many accidents during sports can be prevented by taking appropriate preventive measures. Students who participate in games and sports activities should be given safe and secure environment and facilities for enhancing the confidence of parents as well as students. Injuries can be prevented by knowing the reasons due to which injuries occur and observing the safety measures during playing. While constructing play arena and sports facilities, the needs of differently abled students should also be kept in mind.

Why do sports injuries occur?

Injuries during sports take place due to many factors, which includes careless attitude of the player towards fitness and training. Some of the important factors that are responsible for the sports injuries are—

- a) poor equipment, surface and floor.
- b) lacking in the knowledge of rules of the game.
- c) lack of technical and tactical knowledge.
- d) lack of fitness and conditioning.
- e) not observing safety rules while playing technically difficult sports like gymnastics, diving, judo and wrestling, etc.
- f) lifting of heavy weights without helpers may lead to accident and cause severe injury.

How to prevent sports injuries?

Sports injuries can be prevented in sports arenas, during competition and in technical sports. Supervision by coach and instructor will always help to avoid sports injuries during playing, training and competition.

Do You Know?

Developing physical fitness may help a player to prevent injuries up to 60 per cent in that particular game, it is scientifically proven that good physical fitness helps in better reaction ability, decision making ability and enhances self-confidence of the player.

Activity 7.2

Gather information regarding the sports injuries that occur in swimming pool and gymnasium.

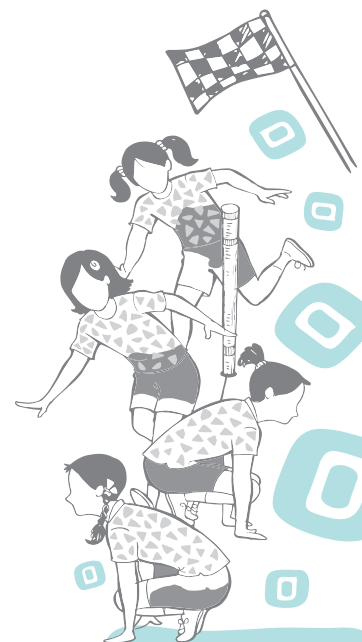

Activity 7.3

- Collect more information about the preventive measures to be taken while developing sports facilities.
- Compare and analyse it with the steps taken by your school.
- Discuss with your classmates.
- Suggest ways.

Prevention of injury related to sports facilities

There are various ways to amend sports infrastructure in order to curb accidents during competition and during training of sports.

Prevention of injury related to competition

Preventive measures to prevent sports injury should also be taken before competition.

- Proper warming up should be done before going for any games or sports. Warming up helps to enhance body's reflex actions and reduce the chances of injury.
- Proper safety measures should be adopted for competition such as safety gears and clothing for sports.
- Players should follow rules and regulations of the competition to prevent injuries.
- All the equipment related to the sports should be checked thoroughly and any equipment which may not be in good shape or broken should be replaced or get repaired.
- Officials of the competition should also evaluate the playing arena before the start of game.

Technical measures for prevention of injuries

Besides the above preventive measures to avoid sports injuries, some important technical measures should also be observed to prevent injuries.

- Players should work on their fitness and conditioning to avoid tiredness during sports competition. Tiredness hampers the reaction and negatively influences the speed of players. A tired player is most likely to get injury during performing or playing, which can be prevented only by enhancing the physical fitness level.
- All the sports where difficulty level of movements is high, possibility of occurring injury are likely to be higher. It is suggested to the players to practise difficult technical movements of sports before taking active participation.
- Coaches and trainers should guide students regarding the safety rules at regular intervals and observe the safety measures taken by them.



- d) Proper nutrition also helps to avoid sports injuries occurring due to stress or overload training. Nutrition helps to repair and build the ruptured muscle fibers.
- e) Selection of the right kind of shoe and sports uniform also helps in preventing injuries like bruises, blisters, broken nails, sprain, strain and shin pain, etc. Every sport requires different kind of sports movements and speed. Thus, it is suggested to select the shoe and sports uniform according to suitability to a given sports condition to avoid injury.

DEALING WITH ALCOHOL, SUBSTANCE ABUSE INCLUDING COMMON MEDICINES DURING ADOLESCENCE

Adolescence is particularly a vulnerable time in a person's life. Navigating this stage of life can be challenging even for the most 'normal' or well-adjusted adolescents. Substance abuse is a menace, especially during the adolescence as it affects their physical, social and emotional growth. Of all the substances, alcohol and tobacco (including *pan masala*, *gutkha*, *khaini*, cigarette, *beedi*, etc.) are two of the substances most commonly misused and abused by adolescents. Being easily available, many children are exposed to these in their homes at a very early age. Parents are role models, whether good or bad, and children of such parents who misuse these substances are at a greater risk of getting into the addiction. However, with proper treatment and support of loved ones, the youngsters can surely overcome their addiction habit and live successful and happy lives.

Why is tobacco use unhealthy?

Tobacco is used in various forms such as smoking (cigarettes/*beedi*/*hookah*); smokeless (*pan masala* with tobacco, *gutkha*/*khaini*).

You know that cigarette smoking is injurious to health. Most people believe that *beedi* is safer than cigarette. But smoking *beedi* is also equally dangerous.

As you know that the nicotine present in the tobacco leaves is highly addictive. It raises the blood pressure. There are about 4000 chemicals found in the smoke from the cigarettes which become a cause for different kind of cancers.

Carbon monoxide gas exhaled by the smoker, is highly poisonous. Tar, a substance resulting from the burning of tobacco leaves, is similar to coal tar used for building the roads. So just imagine the harm it causes to the lungs!

Do You Know?

Do you know that half of the users who started the use of tobacco in their youth will be losing their lives by their middle age?

Do You Know?

You would be surprised to know that nicotine is used as insecticides and pesticides in agriculture.

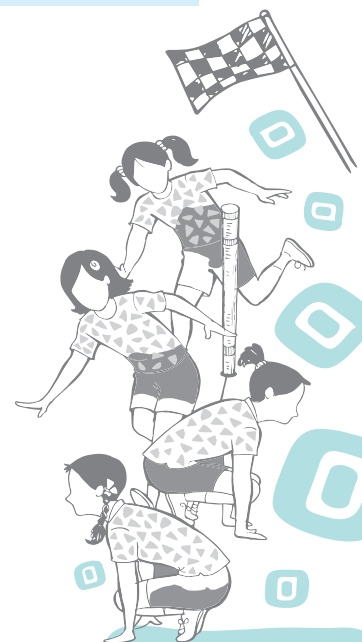

Say “NO” to tobacco.

Remember, one moment of wise decision is the foundation for future happy life for you and your family.

Case Study

You must have seen the short film on Mukesh shown in theatres before any film, who dies at a very young age due to eating Gutkha. Discuss the case of Mukesh in the class and the effects of smoking.

Table 1: Some of the Constituents of cigarette smoke

Constituents	Cancer causing chemicals	Toxic metals
Toluene	Vinyl chloride	Arsenic
Carbon monoxide	Benzene	Chromium
Butane	Polonium 210	Cadmium

Smokeless tobacco

You have heard and seen the advertisements of *pan masala* and wondered what it is made up of. *Pan masala* contains *supari*, that is arecanut or betel nut, which is a traditional item and a part of many religious ceremonies in our country. Most of us believe that *pan masala* is not harmful as it is just a mixture of areca nut cuttings, commonly known as *supari*, food flavours and sweeteners. Actually it is a specialised, ingenious mix of traditional items and chemical products developed to cause addiction. New formulations of *pan masala* are constantly developed and introduced in the market to encourage initiation and sustained use of these and other similar products with an objective to deliver higher “highs” to the addicts.

A dangerous fact which is not known is that continuous use of tobacco causes oral cancer. Its use by the pregnant mothers is nearly as dangerous as alcohol drinking. If taken during pregnancy, even the unborn babies are harmed by the chemicals present in *gutkha* and *pan masala*.

Health hazards of tobacco and substance misuse

Substance misuse affects all the aspects of life of the user. Smoking causes different types of cancers, the most common being lung cancer. Research has established that *pan masala*, *gutkha*, and *khaini* all cause oral cancer. All types of tobacco products that mention ‘low tar or additive-free’ are harmful. Substance misuse in any form leads to dependence and addiction. It affects the personality and makes one angrier, volatile, depressed and tense. The day-to-day activities along with thinking and memory are affected, resulting in a negative impact upon the work in school/college/job.

Effect of tobacco abuse among women

Have you noticed attractive advertisements of lighted cigarettes? Though we mostly see men smoking, the young women are one of the biggest targets of the tobacco industry. The tobacco industry organises richly-funded



marketing campaigns targetting young children through advertisements highlighting and falsely linking the tobacco use with behaviour aspects such as freedom and liberty, or beauty, slim figure and prestige.

Marketing strategies lure consumers especially the youth, with misleading categories, such as 'light' or 'low tar'. More young children smoke 'light' cigarettes, often in the mistaken belief that 'light' means 'safer'. In fact, 'light' smokers often engage in inhaling more deeply and more frequently to absorb the desired amount of nicotine. Women who smoke are more likely to experience infertility and delays in conceiving than those who do not. Smoking during pregnancy increases the risks of premature delivery, still birth and death. Smoking increases women's risk for cancer of the cervix as well.

Activity 7.4

Look at the pictures given below. They look scary. You may have seen such pictures on cigarette packets. It is mandatory to display pictorial warnings on tobacco products in India and many other countries.



- Find out which countries have very gory and scary pictures on the cigarette packets. Make a collage and display with a message.
- Form a chain of five students and share the benefits of not smoking with them
- Plan and stage a role play on "Say No to Tobacco".

How can we identify the symptoms of alcohol or substance abuse among children during adolescence?

Symptoms to observe for alcohol/tobacco abuse

- Feeling depressed, hopeless, rundown or even suicidal
- Being selfish and not caring for others
- Frequent absent-mindedness
- Money or valuables disappear from home
- Irritability and aggressiveness, violent behaviour
- Declining grades
- Important routine activities such as homework, and sports getting affected

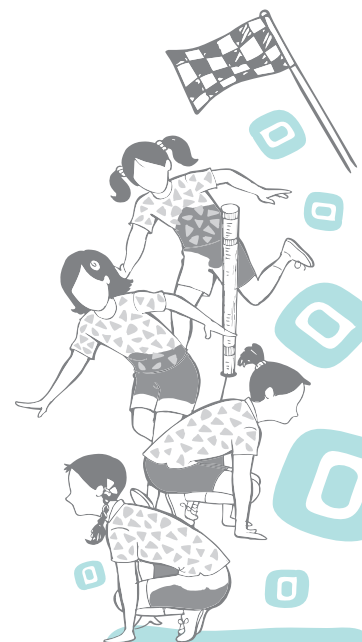

- Having a new friend circle, often not disclosing to family
- An urge to drink on a daily basis
- Avoiding family and friends, spending more time alone in order to consume drugs or alcohol
- Taking risks, including driving rashly as well as having risky behaviour.

Reasons for Alcohol Consumption and Substance Abuse

Many teenagers believe that drinking alcohol is a way of gaining acceptance and admiration of their peers, fitting in the friend circles and a way to show off that they have grown up. Studies have shown that many adolescents started substance abuse because of the pressure from their friends.

Some children indulge in substance abuse to show their anger or a way of rebelling against their parental or societal norms. For many, it is due to curiosity. Sometimes it is done to explore the unknown behaviour. No matter whatever the reasons are, substance misuse is not very healthy and is dangerous.

Some of the adverse effects could be:

- Greater difficulty in focussing and paying attention.
- Poor school performance.
- Depression and anxiety.
- Unnatural deaths, for example from motor vehicle accidents, due to drunken driving.
- Tendency to indulge in crimes like stealing, fighting, etc.
- Suicidal tendencies are much higher in children of adolescence age who drink or engage in substance misuse.

Given below are some of the most common myths and facts related to substance abuse:

Myth	Facts
There is no harm in trying a drug just once, because one can stop after that.	Almost all drug addicts start by trying just once. Once the drug is taken, the user is always amenable to further drug intake, which becomes a part of their habit.
Drugs increase creativity and make the user more imaginative	Drug addict loses clarity and may become incoherent over a period of time.



Drugs can sharpen thinking and lead to greater concentration.	Drugs induce dullness and adversely affect the normal functioning of body and mind.
Will power alone can help a drug addict to stop taking drugs.	Besides strong will power, love and support of family and friends, medical and psychiatric treatment may be needed to come out of drug addiction.
Alcohol helps people forget their problems.	Very often the opposite is found to be true. People bring up forgotten problems under intoxication. Alcohol only adds up to the existing problems.
Drug use makes one cool and better accepted by peers and classmates.	In the beginning, it may be seen that the use of drugs helps in winning more friends but this is a myth as these peers are not true friends or well-wishers. Furthermore, over a period of time, drug dependence makes one asocial and isolated.
Inhalants are basically harmless even though people make a big deal about them.	Using inhalants such as thinners, glue, cleaning fluids can cause permanent damage to organs like the liver, brain and nerves. They are also extremely flammable and can cause burns if matches are lit nearby.

Case Study

Three friends — Mani, Adil and Ronny met at a marriage party. Mani and Ronny wanted to drink in celebration and compelled Adil, (who has never had a drink before) to join them. They insisted him that he should join them for the sake of friendship. Adil is in a dilemma. On the one hand, he doesn't want to lose his friendship but on the other he is conscious that nobody in his family drinks alcohol. He has also learnt from his parents that alcohol is harmful for health.

Questions for discussion

1. What are the choices that Adil has?
2. What would you have done if you were in Adil's place?
3. How else could Adil's friends have celebrated?

Common medicines

There has been a growing trend of taking medicines by the people not only for the treatment of certain diseases against proper prescription but also for other reasons such as cosmetics, weight loss or weight gain, etc. Often these are purchased through sales over the counter, without any proper prescription. This trend is seen more among children of adolescence age and younger generations.

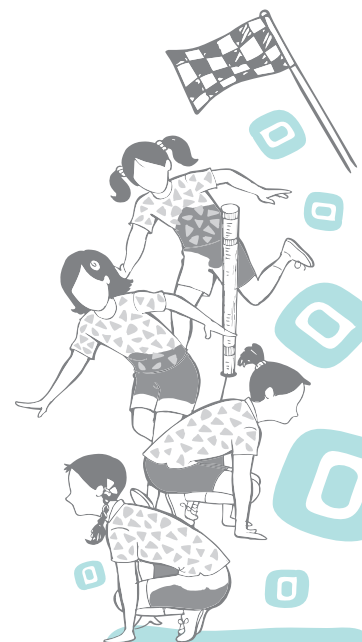

It is always advisable to seek the advice of a doctor and consume only those medicines that have been prescribed. One should never decide one's own medicines (without prescription from a doctor) whatever the ailment be. One should not fall prey to false advertisements asserting that certain drugs or medicines will help in reducing or gaining weight or enhance the stamina or cosmetic beauty.

How to use medicines?

A medicine can be both beneficial and harmful, depending upon how it is taken. When a medicine is taken in the manner as prescribed by the doctor, it can be beneficial but when a medicine is not taken in a manner prescribed by the doctor (overdose) or it is taken with some other substances that it should not be combined with, it may lead to adverse effects on the body.

Medicines should always be stored in a cool dry place and away from direct sunlight. Some of the medicines may also need to be stored in the refrigerator. So follow the directions on label.

- A medicine is anything that is used to diagnose, prevent or treat illness in humans.
- The basic function of medicine is to aid the healing process of the body. The medicine acts as a catalyst in stimulating the natural healing process of the body.
- Medicines should be used to assist the body's mechanism to heal itself.
- We should not be too dependent on medicines. It is rather important to work towards achieving a physical state in which we can regain and recover without or with least possible aid of medicines.
- Prescription drugs and over the counter medicine are the ones prescribed by the doctor upon examining the patient for treatment of their illness. While over the counter medicines are the ones that a patient may buy without consulting a doctor.
- All medications which are sold without a prescription have the potential to cause harm to the body. These drugs and medicines may be sold as advertisements to help reduce or gain weight, enhance cosmetic beauty, etc.

What precautions should we take before taking medicines?

Always follow the dosage of medicine as prescribed by the doctor and the time intervals. Follow other instructions carefully before consuming any medicine, such as taking medicines before or after meals, etc. Medicines should be taken with water rather than with tea, milk or juice, etc.



DOPING

Concept of Doping

Doping is not a new trend brought on by the advent of modern pharmaceutical agents. History shows that athletes in the ancient Olympic Games were willing to take plant extracts in a bid to perform better than their competitors. Performance enhancing drugs and dietary supplements have been around since the ancient Olympic Games. Because of the ethical considerations relating to unfair advantage during competition and the potential for the adverse effect, most athletic governing bodies have generated a list of substances that are banned from national and international competitions. Doping, is a term used for performance enhancing drugs in sports and often understood as the use of such drugs which are considered helpful to improve athletic performance. Many drugs have been banned in sports as they are deemed to provide an unfair advantage, pose a health risk, or are seen to violate the ‘spirit of sport’. The use of banned drugs by athletes is referred to as ‘doping’.

Doping is defined by the International Olympics Committee (IOC) as, ‘the use of any method or substance that might harm the athlete, in a quest to gain an unfair advantage, over his or her fellow competitors’. Hence, training at altitude to increase the blood’s ability to carry oxygen is allowed, but the use of drugs, to achieve the same result is considered unethical and prohibited by the authorities.

Rigorous testing procedures have shown many notable athletes to be trying to ‘beat the system’ by taking such drugs. Most notably, Ben Johnson, in 1988, who won the 100 m sprint in a new world record time of 9.79s, was tested positive for steroids, and lost his gold medal and world record. The reasons to ban doping in sports are mainly the health risks of performance-enhancing drugs, the equality of opportunity for athletes, and the exemplary effect of drug-free sport for the public. Anti-doping authorities state that using performance-enhancing drugs goes against the ‘spirit of sport’.

Why Doping?

Most athletes take drugs—

- to enhance their physical performance in an attempt to prevent them falling behind other competitors even at the cost of damaging their health and risking their sports career.
- to help them wind down and relax,



Fig. 7.1: Medicine label showing date of manufacturing and expiry date

Activity 7.4

Find out when was the doping case first recorded in an International Competition.

Do You Know?

EPO-Erythropoietin, is a peptide hormone, i.e., produced naturally by the human body.

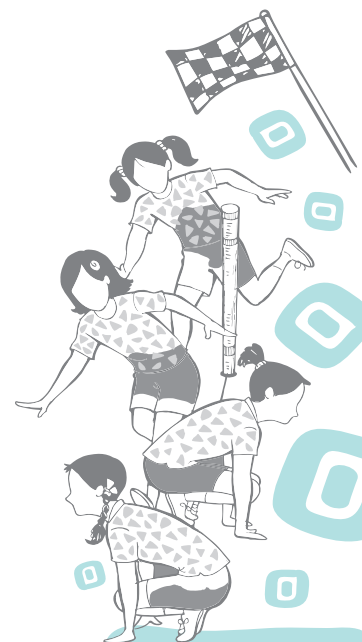

Do You Know?

- Players are selected for doping control either via a random draw conducted by the Doping Control Officer (DCO), witnessed by the team or representatives.
- The World Anti Doping Agency (WADA) is a foundation created through a collective initiative led by the International Olympic Committee (IOC).

- to cope with the pressure and stress associated with constant battle to win all the time
- to boost their own self-esteem and confidence,
- to mask the pain of certain sports injuries,
- to control and reduce weight,
- to hide the use of any other banned substances.

Doping in Sports

In competitive sports, doping refers to the use of banned performance-enhancing drugs by competitors, where the term doping is widely used by organisations that regulate sporting competitions. The use of drugs to enhance performance is considered unethical by most international sports organisations, including the International Olympic Committee. Although, ethicists (World Health Organisation) have argued that it is not different from the use of new materials in the construction of apparels and sporting equipment, which can also aid performance and give competitors an unfair advantage.

Classifications of Doping

The technology in our world today is truly amazing. People are discovering new and exciting ways everyday to make our lives easier and more enjoyable. Doctors and scientists are also discovering ways to help us live longer and finding ways to cure our bodies from many different illnesses. Medicine today is without a doubt much better than in past years. Doctors and scientists continue to discover ways to help create the ideal athlete in the world. They find ways to use drugs that were originally set out for some other function and use it to improve the performances of athletes today. Besides the other unethical practices used by athletes, the two principal categories of performance-enhancing substances considered as the main source are:

1. Dietary supplements
2. Injectable supplements—Hormones and Drugs

Dietary Supplements

Dietary supplements are highly refined products that should not be confused with food. They may not have any positive nutritional value; hence, not referred to as nutritional supplements.

Hormones

A variety of endogenously produced hormones are used to enhance athletic performance. The most commonly used



hormone is 'testosterone'. This hormone is known to produce strength and stimulate the function of skeleton muscles with higher level of energy. Hormone produced and secreted by different organs of the body are stored and employed by athlete as 'Ergogenic aids'.

Drugs

A drug encompasses substance that changes the body's function. A drug is a chemical substance that, when absorbed into the body, can alter normal bodily function. This includes the substances that stimulate hormone secretion. If a substance looks like a medicine or is administered differently from the way in which foods would be consumed, it may be classified as a drug.

Basic Doping Drugs used in Sports

The basic drugs which are used for doping purposes in different sports are described below for better understanding about the drugs.

Narcotics

Narcotics are used as doping in sports. They are injected into a human's blood stream, or muscles, or under skin. Narcotics can also be swallowed. Consumption of narcotics reduces, eliminate, and hide pain. Examples of narcotics are morphine and methadone. They are also used for moderate inflammation. This drug is commonly used in sports with less recovery time in between games. Athletes from football and hockey games commonly use narcotics.

Side Effects: Narcotics decrease heart rate, causes nausea, and vomiting.

Steroids

The well-known doping drugs called anabolic-androgenic steroids are a group of powerful chemical compound, related to the male sex hormone 'testosterone'. The original purpose of steroids was to help with different diseases. It was developed in the 1930's. Consumption helps to produce more hormones in the body.

Side Effects: Consumption can lead to early heart attacks, strokes, liver, tumours, kidney failure, and serious psychiatric problems. Steroids can be injected with needles, which cause risks of infections, such as HIV/AIDS and Hepatitis B and C. Physical symptoms include developing a very large head, acne flare ups, aggressive behaviour and mood swings.

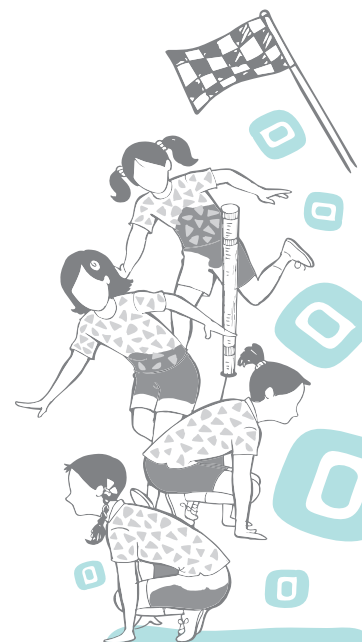

Gene Doping

Gene doping probably began in the year 2001, when the International Olympic Committee Medical Commission came together to discuss the adverse effects of gene therapy in sports. World Anti Doping Agency in 2002 took the action immediately and banned gene doping. Genes can be injected into muscles to prevent muscle-wasting disorder and this camouflages with the other human genes thus making gene doping almost impossible to detect.

Side Effects: Gene doping is very dangerous for the human body as it leads to abnormal growth, extra muscles in the body which needs more blood circulation during contraction hence, may lead to lack of blood for other systems and may cause serious problems for the user. Gene doping is susceptible to extra growth of unwanted hair, heart related problems, nervous breakdown and suspecting to cancer at an early age.

Blood doping

Blood doping is a very high intense type of doping. It increases red blood cell mass and thereby, delivering more oxygen to the muscles. Athletes use this unethical practice with the help of pathologist and medical practitioners, usually in the sports like cross-country, cycling, and swimming, etc. Blood doping vastly increases an athlete's endurance. The red blood cells are then separated and stored in a cold area. The blood is then fused back into the body about a week prior to the athletes' high endurance event. Blood doping increases the capacity of cardiovascular system and helps delaying the fatigue. This is all unethical.

Side Effects: EPO is a peptide hormone that is produced naturally by the human body. EPO is released from the kidneys and acts on the bone marrow to stimulate red blood cell production. It is well known that EPO, by thickening the blood, leads to an increased risk of several deadly diseases such as, heart disease, stroke, and cerebral or pulmonary embolism. The misuse of recombinant human EPO may also lead to autoimmune diseases with serious health consequences. In blood doping, one to four units of blood is taken out from the athlete's body.

HARMS OF PROHIBITED SUBSTANCES

1. Taking doping drugs can have terrible effects on your body. The well known doping drug, steroids has a number of negative effects on the body. Steroids interrupt the normal development of hormones



throughout your body. When this happens, human body experiences changes that are irreversible. Changes such as reduced sperm production, baldness, breast development in men, breast reduction and voice deepening for women. The risk of high blood pressure and the risk of heart attacks is very high. If a person takes a large amount of steroids, it increases irritability and aggression.

2. The blood doping causes much stress on the heart. The reason for this is that the red blood count increases which causes the blood in blood stream to become thick. The human heart is not used to pumping such thick blood. This leads to different kinds of heart diseases.
3. Narcotics are a street drug and people share the needles to inject it. This gives the risk of passing different diseases from one person to another. Overdosing of narcotics can cause death. Withdrawal effects include limited vision, reduced sex drive, menstrual problems, chronic constipation, mood swings, and muscle twitches.
4. Lean mass builders such as anabolic steroids can cause dangerous increase in the levels of cholesterol, heart attack, hypertension, stroke, liver and kidney damage, jaundice, depression, aggression, mood swings, acne and skin disease, reduced sperm count and impotence in males, and amenorrhea in females.
5. Beta-2 antagonists can cause nausea, headaches, dizziness, muscle cramps and heart flutters, whilst other lean mass builders such as the human growth hormone may be associated with liver problems, heart disease and irregularities in the processing of insulin.
6. Side effects of stimulants such as amphetamines include increased heart rate, blood pressure and body temperature, stroke, hypertension, agitation, anxiety and sudden cardiac death. Strong prescription painkillers such as narcotics are also highly addictive and can impair the mental abilities.
7. Relaxants such as alcohol and marijuana cause impaired judgement, balance, co-ordination and memory, hallucinations and drowsiness.
8. Side effects of diuretics include dehydration, dizziness, cramps, and kidney failure.
9. Those masking drugs used to prevent the detection of other banned substances can cause severe allergic reactions, nausea and vomiting.

Activity 7.5

Make a list of the banned substances used by some athletes to control body weight for a combat sports.

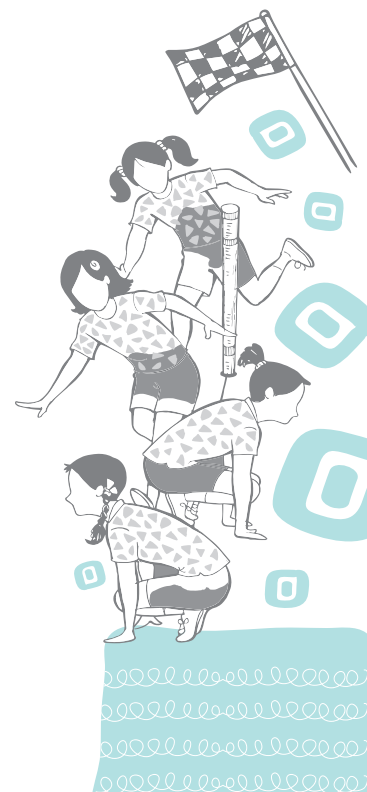

TESTING IN-COMPETITION AND OUT-OF-COMPETITION

Drug testing has become an increasingly large part of both professional and amateur sports. An athlete can be called for drug testing at any time, in or out of competition. During competition, some sports carry out drug testing only on the winning team or top three competitors. Others will be tested by random selection amongst all the competitors. There are two types of doping control tests:

1. In-Competition and
2. Out-of-Competition (OOC) Testing

In-Competition Testing is conducted at a competition venue, while Out of Competition Testing occurs with no advance notice and can occur at any location and at any time.

DOPING CONTROL PROCEDURE

The main purpose of the technical procedures for doping control is—

1. to plan for effective testing.
2. to maintain the integrity and identity of the samples collected, from the point when the athlete is notified of the test to the point when the samples are transported to the laboratory for analysis.



ASSESSMENT

I. Long Answer Questions

1. How can we prevent the injuries by preparing good sports facilities?
2. What are the safety rules one can observe when buying a sports shoe?
3. What is meant by safety through sports instruments?
4. How does sports uniform help in safety of the sports persons?
5. What precaution can be taken to prevent injuries in the gymnasium?
6. How can you curb the accidents in swimming pool?
7. Physical fitness may be used as a tool to prevent sports injuries. Elaborate.
8. Write down the myths and facts about substance abuse.
9. What is doping and what are the side effects of blood doping?
10. Why do athletes dope? Explain the side effects of prohibited substances.

II. Short Answer Questions

1. What is meant by safety measures?
2. Why is the fabric of T-shirt important for athletes?
3. Write two safety measures in relation to swimming pool.
4. Write two ways to prevent sports injury.
5. Does cigarette smoking raise your status? If no, why?
6. Why tobacco use is deadly?
7. What three things should you focus on when buying medicines?
8. What are the categories of doping?

III. Multiple Choice Questions

1. Medicine should be purchased _____.
(a) as per prescription of the doctor
(b) as advised by the chemist on the basis of our health problem
(c) after observing the date of manufacture and the date of expiry
(d) (a) and (c) both
2. Medicines should be consumed by the patient _____.
(a) as advised by the doctor
(b) always after the meals



- (c) always before meals
- (d) whenever the patient feels like taking the medicine
- 3. Which type of surface is used in modern times to play Kabaddi that helps to prevent injury?
 - (a) Synthetic surface
 - (b) Mud ground
 - (c) Grassy ground
 - (d) Cinder surface
- 4. How does warming up helps to prevent injury?
 - (a) Warming up enhances reaction ability
 - (b) Warming up prepares the player for making smooth movements
 - (c) Proper warming up prepares and athletes mentally and physically for sports
 - (d) All the above

IV. Match the Following

- | | |
|---|--------------|
| 1. Nicotine which is present in tobacco leaf is also found in | Tar |
| 2. Used for making roads | Insecticides |
| 3. Tobacco use severely affects | Smoking |
| 4. Can cause cancer | Lungs |

V. Projects

1. Make a table of the various medicines being taken by a sick family member.

Name of Medicine	Dose Prescribed	Timings	Expiry date on the label of package	Remarks

2. You would have seen many women smoking beedi or cigarette. Some may even be pregnant. Discuss with two such women the harmful effects of tobacco use among women, especially the pregnant women.

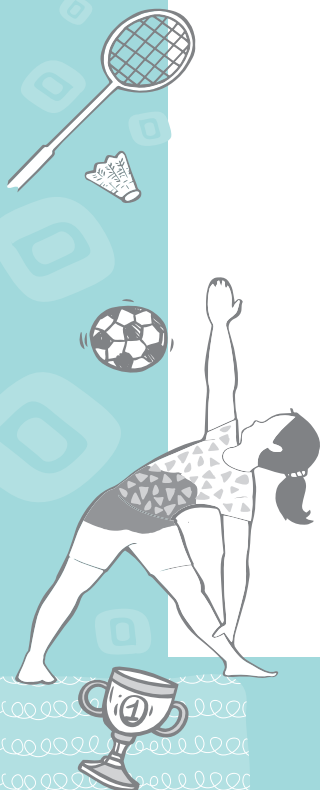

3. You would have seen many small shops, including *pan* shops which sell cigarettes and *pan masala* products to the children. Do you know that sale of any tobacco products to children and sale of these items within 100 yards of any educational institution is banned? It is sometimes very difficult to remove these shops. Hold discussion with the Residents Welfare Association and Parent-Teacher forum to stop the sale of any tobacco product near your school.
4. Discuss with your class teacher and students' committee as to what actions can be taken to make your school a tobacco-free zone.

© NCERT
not to be republished





HEALTH RELATED PHYSICAL FITNESS

8

Physical fitness directly influences the health of an individual. So to keep ourselves healthy, fitness sessions should be incorporated in our daily routine.

‘Physical fitness is a state of health and well-being. It develops your capacity to perform better in sports, your job and day-to-day routine work. This is achieved through moderate/vigorous physical activities, balanced diet and proper recovery.’

Regular planned fitness activities like walking, jogging, cycling, swimming and yoga improve health and physical fitness of an individual. It also reduces the risk of heart diseases, diabetes, hypertension and depression. So, we can say that physical fitness is related to — ‘well-being’ and ‘wholesome development’ - of an individual.

There are five components of health related physical fitness—

1. Muscular Strength
2. Endurance
3. Flexibility
4. Body Composition
5. Cardiovascular Endurance

Muscular Strength

Muscular strength is directly related to force production. Not only in sports but it is related to our each and every movement. Movement of our body parts is possible due to strength be it flexing a finger or getting up from the bed.

Paralysed people cannot move their body parts because they have lost the capacity to produce strength.

A new born baby cannot stand up and walk because they has less strength. So, we can say that for every movement of body part or for moving body from one position to another position, strength is required.

Whenever we think about sports performance, the first thing which comes into our mind is the muscular strength. Normally we use the term strength instead of muscular strength. If we ask someone a question, do you have the strength to do this physical work? He or she will knowingly or unknowingly flex his or her muscle and say I have the strength to do this. This shows in itself that somewhere strength is associated with muscles.

Strength is normally understood as the ability of the muscle or group of muscles of an individual to exert force against the resistance. If we are talking about exerting force then the question which comes in our mind is, why do we want to exert force? For this we have to look into the nature of the sports activities. We try to act against the resistance. Now the resistance can be of two types. It can be internal resistance like your own body weight or it can be external resistance like opponent's body weight. In some of the cases we act against the resistance which we cannot conquer and in some of the cases we act to overcome that resistance. In both the cases we exert force with the help of our muscles.

Muscular strength is thus, 'the ability of the muscle or muscle groups of an individual to exert force on the resistance to overcome it or to act against it as per the demand of the sports activity'.

Moving further, we look at how the muscular strength ability is used according to the nature of sports. We find that sometimes we need to apply force against the maximum resistance, but it is for shorter duration and sometimes we need to apply the force for longer duration. Taking into account the nature of sports as far as strength abilities are concerned, we can divide the strength abilities into three parts—

- (a) Maximum Strength:** The name itself reflects that we are talking about something to its maximum limit. So, we can say that when our muscle or muscles group is able to generate the force with 100 per cent effort by which we are able to tackle the maximum resistance in a single contraction, it is called maximum strength of an individual. It is the ability which is of great use in the sports like weight lifting, throw events in athletics, etc.

Activity 8.1

Compare the strength of your classmates with an Arm Wrestling competitor.

Do You Know?

- Aerobic capacity is the capacity to work in the presence of maximum amount of O_2 and the nature of the work is of longer duration.
- Anaerobic capacity is capacity to work in less amount of O_2 and nature of work is of short duration.

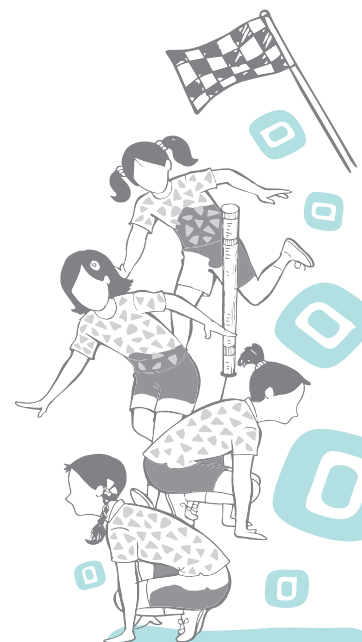

(b) Explosive Strength: In some of the books, you may find this with the name of elastic strength. This is the ability where both strength and speed comes into play. When the muscle or group of muscles contract with high speed to overcome or to act against the resistance with 70 per cent to 80 per cent effort, then it is called the explosive strength. There are several examples where the explosive strength is required such as jumping, sprinting in athletics, boxing, etc.

(c) Strength Endurance: As it reflects from the name itself that it is related to the work which is done for longer duration. It is both strength as well as endurance which comes into play. In simple words, we can say that when our muscle or a group of muscles act against the resistance with 50 per cent to 60 per cent effort or try to overcome the resistance for longer duration in spite of having fatigue, then it is called that the individual is having strength endurance. There are many sports where we can easily see the use of this ability such as hill running in cross country race, cycling, swimming, etc.

As we know that strength depends upon the contraction of muscles and several other factors. So let us have a look on the factors which play major role in the liberation of force by the muscles. These are as follows—

1. Neural Control: How much force the muscle will generate largely depends upon three major factors.
 - Number of motor units involved in the contraction — If the greater number of motor units are recruited then more amount of force will be generated.
 - Size of the motor units involved in the contraction — If the size of the motor units is greater, then also, the amount of force generated will be higher.
 - Intensity of nerve impulse — If the intensity of nerve impulse is faster, then also, the force generated by the muscle will be higher.
2. Muscle Cross-section: It is well known to everyone that liberation of force largely depends upon the size of the muscles. The more the size, the more force it will generate.
3. Muscle fibre: Muscles are made up of two types of fibres, one is fast twitch fibre (white) and another



is called slow twitch fibre (red). Both the fibres are present in the muscles. The quality of the muscle depends upon the proportion of the fibres in the particular muscle. If the fast twitch fibres are more in ratio, then the muscle will contract faster and generate more force. This type of muscle has anaerobic capacity. Whereas, the muscle having slow twitch fibre will generate less force in comparison to the muscle with fast twitch fibres.

4. Energy supply: Muscles get their energy by the breakdown of ATP (Adenosine Triphosphate) and CP (Creatine Phosphate) which is stored in the body. The amount of ATP and CP store is very essential for the muscular activities as it provides the energy to the muscles.
5. Psychological factors: In many of the situations, the psychological factors contribute a lot in getting more forceful muscular contraction. The factors such as anger, aggression, motivation, etc., play a very crucial role in pushing their mind to develop very strong nerve impulse which can lead to activate more number of motor units.

Methods of Strength Improvement

Strength is regarded as a very essential part of sports performance. It is a conditional ability and can be improved to a greater extent by the training. There are various methods by which one can achieve the level of strength one wants. Whenever we think about improving the strength ability of an individual, the first thing which comes to our mind is the structure of our activity where we are going to use this strength. In some of the activities, our own body weight acts as a resistance and in some cases, external resistance plays the maximum role. For example, in cross country races while running on the hill, our own body weight acts as a resistance and in weight lifting, external weight acts as the resistance. So, when we design resistance training for developing strength ability of an individual, we keep both the conditions in our mind. We know that countering the resistance again and again will help us to improve our strength ability. For improving the strength ability, the following methods are used.

Activity 8.2

Perform push-ups, pull-ups, sit-ups along with your classmates and find who scores highest in these activities.

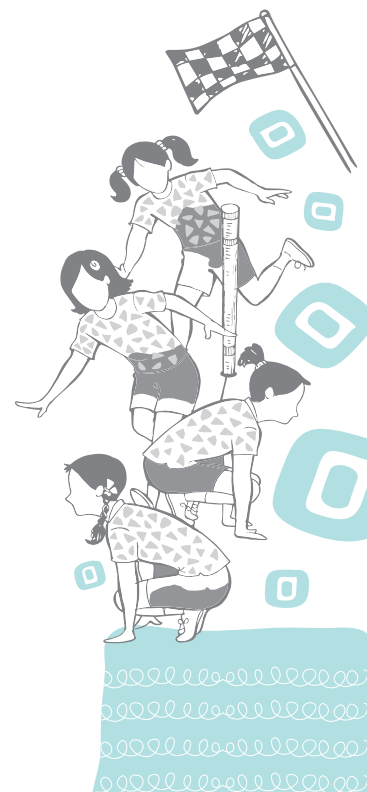

1. Using our own body weight as a resistance: In this method, we design our strength training in such a way that our own body weight acts as a resistance, for example, rope climbing, hill running, etc. In this, the pull of gravity plays a very vital role. We try to carry our own body against the gravity which helps us to improve our muscular strength. This method is very effective for the young athletes.



Fig. 8.1: Exercise with own body weight

2. Using external weight as a resistance: In this type of training, the athlete uses external weight as a resistance. This is a more effective method of improving the strength abilities. For example, weight training where weight plates, medicine ball, weight belts, etc., are used to develop strength ability. The resistance is increased or decreased according to the need. Along with weight training, several other methods are also used for improving the strength where external resistance is used. For example, swimming against the flow of water in the river, drag running, etc.



Fig. 8.2: Exercise with external weight as resistance

Endurance

When an individual continues doing physical activity for a longer period of time, then he or she is said to have good endurance for doing that particular work. By nature, it looks like both physiological as well as psychological abilities of an individual play a crucial role in determining the endurance ability.

As an individual continues doing any work for longer duration, after some time he or she may feel physical as well as mental fatigue. But in spite of this, if he or she is able to continue the work for longer duration then this shows that he or she is having good endurance.

Endurance is normally understood as the ability to do any work for longer duration. It is task specific in nature. We come across many such examples in our daily life which shows that this ability is task specific such as we see a teacher who stands and continues taking his classes for hours together. If the same teacher is asked to run for an hour or more, he or she will not be able to do so. At the same time, if you ask a long distance runner to run for an hour, he or she will do it easily, but you ask the same runner to sit and work in the office for long hours, he or she may not be able to do it. Mental toughness, interest for the task and physiological qualities all have a very important role to play when we talk about endurance.

Activity 8.3

- Perform shoulder press, bench press and squats and find out who scores highest in these activities.
- Compare the body weight of a long distance runner and a sprinter in your school and see the difference.

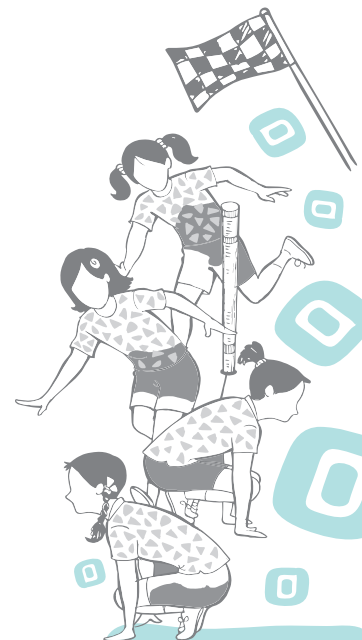

So considering all such things we can say that 'endurance is the physiological as well as psychological ability of an individual to do some specific type of work for longer duration with the desired quality under the condition of fatigue'.

Endurance can be divided into three types, as far as nature of the activity is concerned.

1. **Basic endurance:** This type of endurance ability makes an individual capable to carry out any type of work for longer duration. It is not task specific. This type of endurance largely depends upon aerobic capacity of an individual. In this type of endurance, the pace of the activity is slow.
2. **General endurance:** This type of endurance ability makes an individual capable to carry out any type of work for longer duration with various movement patterns and pace. The nature of the pace may change according to the demand of the activity.
3. **Specific endurance:** This type of endurance ability makes an individual capable to carry out a specific type of work for longer duration with a set type of movement patterns and pace. This involves aerobic as well as anaerobic qualities of an individual and is highly trainable in nature.

Factors determining endurance

Various physiological and psychological factors are involved in determining the endurance of an individual. These factors are muscle fibre type, aerobic capacity, anaerobic capacity, movement pattern and psychological factors.

1. **Muscle fibre type:** Muscles are made up of two types of fibres, namely fast twitch and slow twitch fibre. Both types are present in the muscle of an individual. If the ratio of slow twitch fibres is more, then an individual will possess the aerobic capacity which will enable him/her to have endurance ability. In the same manner, if there is higher ratio of fast twitch fibres, then an individual will possess the anaerobic capacity and will dominate in strength and speed activities.
2. **Aerobic Capacity:** It is the ability of muscle to utilise more amount of oxygen while working. This type of capacity largely depends upon the oxygen uptake, its transportation from atmosphere to the working muscles and oxygen consumption. Oxygen intake is the amount of oxygen which is



taken from the atmosphere with the help of nose and mouth and is sent to the lungs and from where it is transferred to the blood. Transportation of oxygen from lungs to the target muscle is very important. How much oxygen will be transported depends upon the amount of oxygen absorbed by the blood and the capacity of the heart which will pump the blood into circulation. The amount of oxygen absorbed in blood depends upon the amount of haemoglobin present in the blood which carries oxygen to the target muscles. The capacity of the heart and vascular system of the body will determine how fast the blood will reach to the target muscle. If the heart is strong and has larger chamber size, it will pump more blood in circulation which will help the oxygen to reach the target muscle in less time. Further, when the oxygen reaches the target muscle, it has to be taken up by the muscle and then consumed.

3. **Anaerobic capacity:** It is the ability of the muscle to work in the presence of inadequate amount of oxygen. During such conditions, two types of energy systems work, i.e., splitting of phosphogens and glycolysis of glycogens. The phosphogens, i.e., Adenosine Triphosphate and Creatine Phosphate (ATP and CP) last for 8 to 10 seconds only. The amount of phosphogens can be increased by training. The increased ratio of lactic acid in the muscle decreases the capacity of working muscle, so it is quickly pushed into the blood which makes changes in the pH value of the blood and makes the blood acidic. To avoid this, alkali reserves present in the blood neutralise the lactic acid effect. This system is called buffer system and it is very helpful for endurance performance. Further, an individual's capacity to tolerate lactic acid also plays an important role in deciding the endurance capacity.
4. **Movement pattern:** Economical movement pattern is of great help for saving energy, which in turn helps in improving endurance capacity of an individual. A good technique can save the wastage of energy.
5. **Psychological factors:** This has a big role to play when it comes to endurance performance. Mental toughness to tolerate pain, pushing oneself, etc., has a great impact on continuing the long duration activities.

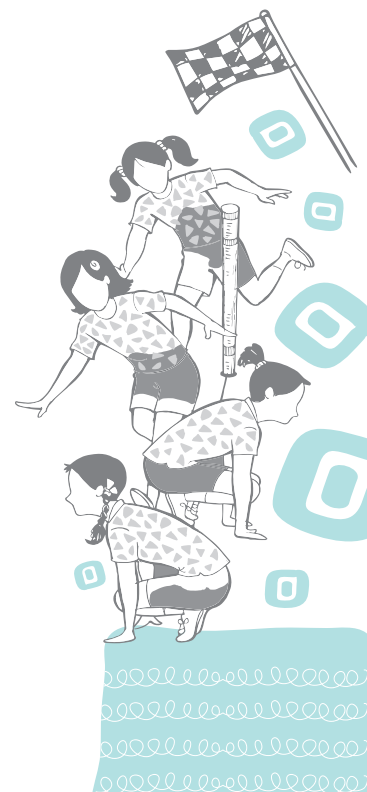

Improvement of endurance

There are various methods by which one can improve his or her endurance. This is highly trainable ability. The methods by which we can improve our endurance capacity are mentioned below.



Fig. 8.3: Improvement of endurance with fast pace

1. Continuous method: The method in which we go for long duration activity without any rest or break in between. This method can be practiced in various forms.



Fig. 8.4: Improvement of endurance through cross country



- a) With slow pace: This method is normally used for very long duration activity in which the pace is slow and helps in developing the aerobic capacity of an athlete. This method has a great effect on muscles. The major changes which take place are — increase in muscle glycogen level, increase of capillaries in muscle and increase in the quantity of oxidative enzymes. Number and size of mitochondria increases, thermo-regulation capacity of the body improves and due to long practice, the movement pattern also becomes economic.
 - b) With fast pace: In this method, the pace is faster. The duration of practice depends upon the fitness of the athlete. This method is very much effective to improve the anaerobic capacity of the athlete.
 - c) With changing pace: In this type of method, the athlete is trained with change in pace. This is very much effective in improving the aerobic as well as anaerobic capacity of the athlete.
 - d) Fartlek method: This method is also called ‘speed play’. In this method, the change of pace is not planned prior to the start of the practice. This method is very effective for mature athletes. The athlete himself decides the pace and duration as per the capacity. This method helps in developing both aerobic and anaerobic capacity.
2. Interval Method: In this type of method, the athlete is trained with sub-maximum intensity and with a short break in between with incomplete recovery. This type of method is very effective and helps in improving endurance capacity. In this type of method, the training load is decided by monitoring the heart rate of the athlete. The interval given in between the exercise is also decided by monitoring the heart rate.
 3. Repetition Method: In this method, the pace is near to or more than the pace of real completion. The distance can be decided as per the need. The interval in between will be given for complete recovery. This method is very much useful for improving the pace judgement and anaerobic capacity.
 4. Competition method: This method is very much effective for learning the tactic of long distance running. This method develops specific endurance and also helps in improving certain psychological factors which play a vital role in carrying out long distance activities. Competition method can be of

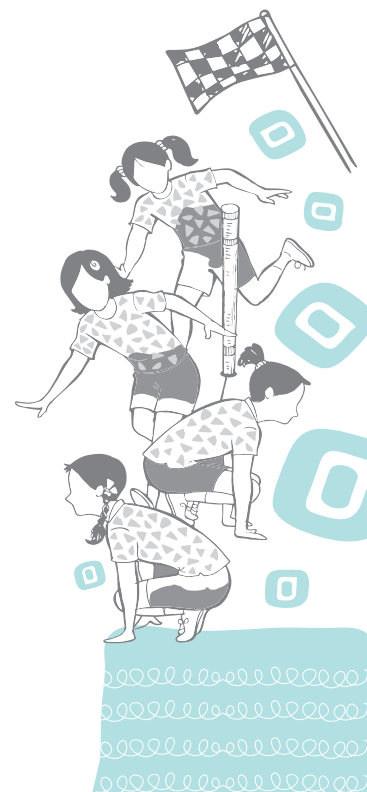

great help in checking the performance and deciding the future training programme. Participating in the matches of respective game/sports is a simple example of competition method.

Table 1: Benefits of Endurance Training

System	Increases	Decreases
Cardio-respiratory System	<ol style="list-style-type: none"> 1. Heart size and volume 2. Blood volume and slight increase in haemoglobin 3. Stroke volume 4. Cardiac output 5. VO_2 max 6. Oxygen interaction with cells 7. Lung volume 	<ol style="list-style-type: none"> 1. Resting heart-rate 2. Sub-maximal exercise heart rate 3. Blood pressure (if high)
Muscular Skeletal System	<ol style="list-style-type: none"> 1. Mitochondria — number and size 2. Myoglobin storage 3. Triglyceride storage 4. Oxidative Phosphorylation 	<ol style="list-style-type: none"> 1. Chances of injuries
Other System	<ol style="list-style-type: none"> 1. Strength of connective tissues 2. Heat acclimatisation 3. High-density lipoprotein Cholesterol (HDL) 	<ol style="list-style-type: none"> 1. Body weight (if overweight) 2. Body fat 3. Total Cholesterol 4. Low Density Lipoprotein Cholesterol (LDL)

Flexibility

It may be termed as the ability of an individual to move his body parts to its maximum range around the related joint. It is measured in degrees, radians or centimetres. This is a motor ability which is of great importance for sports performance as well as for leading a normal healthy life. It can be passive or active in nature.



Fig. 8.5: Passive (Left), Active (Right)

1. **Passive flexibility:** When the movement around the joint is done with external help, then this type of flexibility is termed as passive flexibility. Help may be taken from another person.
2. **Active flexibility:** When the movement around the joints is done without the external help, then this type of flexibility is termed as active flexibility. Further, active flexibility is sub divided into two parts — static and dynamic flexibility.

Activity 8.4

Try to stretch your muscles with and without help and see the difference.



Fig. 8.6: Static flexibility

- a) **Static:** When the individual is executing movement around his joints in sitting or standing position, then it is called static flexibility.
- b) **Dynamic:** When the individual is executing movement around his joints while moving, then it is called dynamic flexibility.



Fig. 8.7: Dynamic flexibility



Do You Know?

The range of motion will be greater in passive stretching in comparison to active stretching.

Factors determining flexibility

The range of movement around a joint depends on various factors which are as follows:

1. Anatomical structure of joint: The range of movement around joints largely depends on the anatomical structure of the joint. For example, ball and socket type of joint has the maximum range of motion in comparison to other type of joints.
2. Ligaments and muscles stretchability: The bones are attached to each other by ligaments. These ligaments have a great role to keep the two bones attached to each other. Their stretchability has a great impact on the movement possible around that joint. The stretching ability of muscles around a particular joint also plays a major role in their movement.
3. Coordination: Coordination between the agonist and antagonist muscles around the joint plays a very crucial role in determining the flexibility around the joint.
4. Strength of the muscle: For any movement, the muscle should have the basic strength to move the associated part or bone. If the muscle is weak, then it will not be able to move the bone to its maximum limits.

Improvement of flexibility

There are a few methods by which we can improve our flexibility, these are:



Fig. 8.8: Ballistic method to improve flexibility

1. Ballistic method: When the flexibility exercises are done with rhythmic movements, then it is called

ballistic method. In this method, the movements around the joints are done with a swing. This type of method is very much effective in improving the range of motion around the joints, e.g., gymnastic movements.

2. Stretch and hold: In this type of method, the athlete is asked to stretch to his or her maximum limit and hold the position for few seconds, then regain the previous position. This type of method is very useful for the improvement of flexibility. This can be done individually or with the help of another person.



Fig. 8.9: Stretching exercise

3. Post-Isometric Stretch: In this, the muscle is isometrically contracted for around 8–10 seconds and as it returns to normal condition, muscle is stretched to its limit gradually. It is also called as

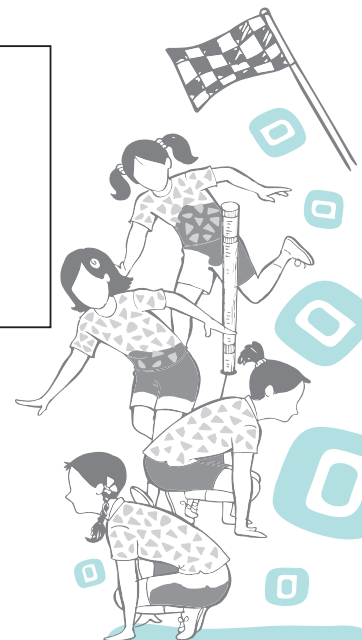

proprioceptive neuromuscular facilitation (PNF). It requires supervision of a trained person and advanced methods to practice.

Physical fitness is not only required for players but also for everyone. One must do various fitness activities to keep oneself physically, emotionally and mentally healthy.



Fig. 8.10: Stretching exercise with the help of another person and equipment

Body Composition

It is the classification of human body into fat weight and lean body weight. It can be assessed using both direct and indirect methods. Direct method for evaluating the body composition is hydrostatic weighing or under water weighing, and assessing body composition by a skin-fold caliper is called indirect method.

Cardio-vascular Endurance

It is the ability of heart, lungs and blood vessels to supply sufficient amount of oxygen and nutrients to the cells to meet the demands of the activity characterised by moderate contractions of large muscle groups over prolonged period of time. Twelve minutes run/walk test can be used to evaluate cardio-vascular endurance.



ASSESSMENT

I. Long Answer Questions

1. What do you understand by health?
2. List and explain the components of health related fitness.
3. Explain muscular strength.
4. Explain the benefits of endurance training.
5. Explain flexibility and its types.
6. Explain the various factors affecting flexibility.

II. Short Answer Questions

1. Define endurance.
2. What is physical fitness?
3. What is interval method?
4. What is Post-Isometric Stretch?
5. List down the four motion factors responsible for range of motion.
6. What is the full form of PNF?

III. Fill in the Blanks

1. Force is produced _____.
2. _____ component helps in improving the number and size of mitochondria.
3. _____ is a swedish method to develop the endurance.
4. _____ method has incomplete recovery in endurance.
5. Body weight _____ with endurance training.
6. _____ is responsible for great range of motion.
7. Flexibility movements done with rhythmic movements are called as _____.
8. Universally practised stretching method is _____.

IV. State whether True or False

1. Passive flexibility training is done with internal help.
2. The bones are attached to each other by ligaments.
3. Muscles are made up of two types of fibres namely, fast twitch and slow twitch fibre.
4. Physical fitness indirectly influences the health of an individual.
5. The ability of muscles to consume oxygen while working is known as aerobic capacity.





MEASUREMENT AND EVALUATION



11152CH09

9

Activity 9.1

Discuss with your classmates about the need of test, measurement and evaluation programme.

Do You Know?

Measurement is a score generally known as data.

Everybody is interested in knowing about what, how and why the things and activities near their surroundings are happening. Because, our day-to-day life is largely associated with all these terms to know the status or level, attitude or skill, cause or effect of someone's effort. To know the answer of any query or assumption, we use test, measurement and evaluation.

WHAT ARE TEST, MEASUREMENT AND EVALUATION?

Any idea or thought cannot take constructive shape without evaluation and it is based on measurement which cannot start without using an appropriate test. Basically test, measurement and evaluation are interrelated, interdependent and follow a continuous process.

Test

Test is a tool to obtain information to determine the specific characteristics or qualities of an individual regarding knowledge, physical abilities, skill abilities, etc. For example, unit test, annual examinations, physical fitness or body measurement (height, weight).

Measurement

Measurement can be quantitative, qualitative or both. It is a score or data in numerical/grading values, indicating the capacity or ability of an individual, which is obtained on the basis of applied test. Students score in their test and examination either on the field or in the classroom is called measurement.



Evaluation

It is the process of interpreting the collected data to measure and make the professional judgement of value or worth. After giving the test, everyone wants to know the feedback or effectiveness of the measures, which can be gathered through evaluation. Evaluation may be formative or summative evaluative process used three steps- process education, objectives, learning experiences and change of behaviour. These steps are performed in sequence.

Measurement and Evaluation programme is very useful for teachers, students and parents in the field of health and physical education, either to check academics as well as the level of fitness. TME process is useful for achievement, diagnosis, prescription, improvement, classification, grading, motivational purpose and also helpful for the prediction of performance.

MEASUREMENT AND EVALUATION OF SELECTED PHYSICAL FITNESS COMPONENTS

Here we will discuss about measurement and evaluation of the major components of physical fitness:

- (i) Muscular Strength: Push-ups, Abdominal Curls and Squat Thrust
- (ii) Muscular Endurance: 1000 meter run/walk test
- (iii) Flexibility: Sit and Reach Test
- (iv) Assessment of Body Mass Index (BMI)
- (v) The Waist-Hip Ratio or Waist-to-Hip Ratio (WHR)

Muscular Strength

As discussed in the previous chapter, muscular strength refers to the ability of the muscle or group of muscles of an individual to overcome or to act against the resistance. It largely depends upon a few things such as physiological factors like cross-section of the muscle, ratio of slow and fast twitch fibers in muscle, coordination between muscles (agonist and antagonist), ATP and CP store, which plays an important role in providing energy to the active muscle or group of muscles. The psychic factors or the present state of mind such as anger, aggression, motivation, emotional state, etc., have positive as well as negative correlation in muscular strength.

For measuring the strength of the muscle or group of muscles, we must have the knowledge of muscles and also of the particular exercise for particular muscle and supportive muscles. For example, while performing the pull ups,

Activity 9.2

Make a list of Physical Fitness Components and discuss it with classmates.

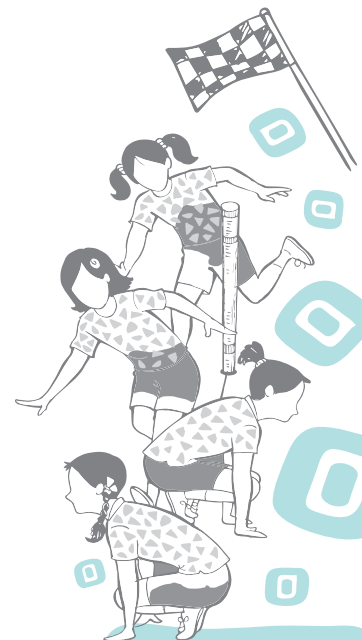

Activity 9.3

Discuss the types of tests to measure leg strength.

an individual lifts his body, the deltoid, latissimus dorsi, trapezius and biceps contract and produce power whereas the triceps stretch and play the supportive role.

Now if we want to measure the strength of upper limb (arms), then pull-ups can be one of the test items, but if we want to measure the strength of lower limbs (legs), then we have to think of other exercises.

Muscular strength can be measured with the help of one's own body weight or with the help of equipment such as dynamometer, tensiometer, weight plates and barbell, etc.

Tests related to Muscular Strength

There are different types of tests to measure muscular strength.

Push-up

The push-up or press up fitness test measures the upper limb muscular strength and muscular endurance.

There are many variations of the push-up test, such as different placement of the hands, how far to dip, the duration of the test and the method of counting the number of completed push-ups.



Fig. 9.1: Good push-ups (above), bad push-ups (below)

This helps in identifying and assessing muscular strength and endurance of the upper body.

Depending on which protocol is to be used, you may need a floor mat, metronome, beat drum, audio tape, clapping or stopwatch.

Procedure

A standard push-up begins with the hands and toes touching the floor, the upper body and legs should be in a straight line, feet slightly apart, the arms at shoulder width apart extended and at a right angle to the body. Push-ups can be started from a plank position. Align your body with your hands on the floor. Keeping the back and knees straight, lower the body to a predetermined point, to touch some other object, or until there is a 90 degree angle at the elbows, then return back to the starting position with the arms extended. This action is repeated, and the test continues until the exhaustion or until individual is unable to perform it in rhythm or have reached the target number of push-ups. Body should be in straight line from head to ankles.

As you are going down, elbows should come to 90 degrees. Hold this position and go up, hold the upward position.

Scoring

Maximum number of correct push-ups done by the participants at a specific given rate or time will be the score.

Abdominal Curl

Abdominal curl test helps to identify and assess muscular strength and endurance of abdominal muscles. For this test, floor mat and stopwatch are required.

Procedure

The individual has to lie in a supine position with flexed knees and elbows. Fingers of both the hands are clubbed with each other and are kept behind the head. Individual is asked to raise his or her upper body and then come back to his initial position repeatedly till the given set of time duration ends.

Score

Number of curl ups done by the participants at a specified rate or in specific time will be their score.

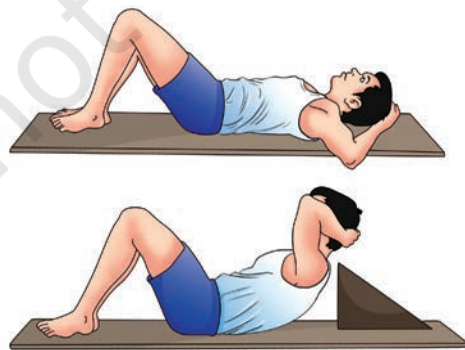
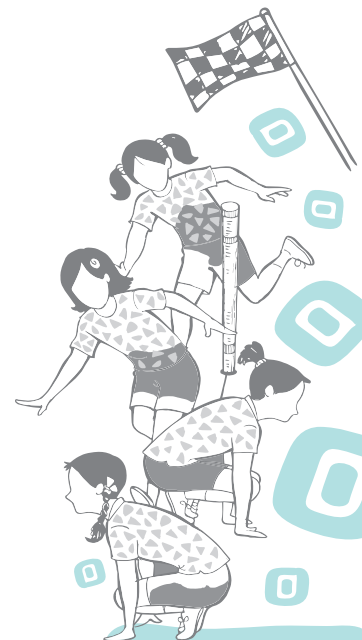

Fig. 9.2: Abdominal curl test

Activity 9.4

- Perform and count the push-ups with your classmates and compare who can do more accurately.
- Make a list of different type of tests to measure abdominal strength and endurance.



Squat thrust

This test enables an individual to identify and assess muscular strength and endurance of the lower body.

Procedure

For this test, follow the given steps—

- (a) Start from a standing position.
- (b) Go down achieving low squat position and place both palms on the floor.
- (c) Take both legs back quickly as shown in the figure and achieve plank position. Quickly come back to the original standing position.

Score

Maximum number of successive squat thrusts performed by an individual in 1 minute will be the score.

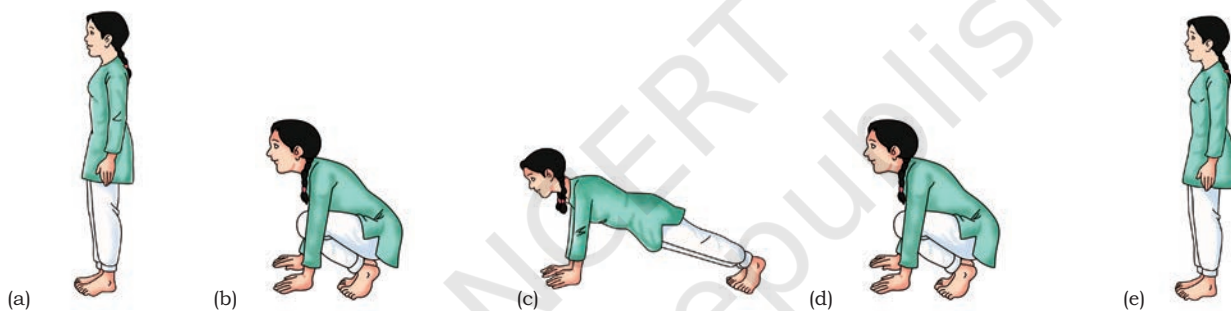

Fig. 9.3: Steps of squat thrust

Muscular Endurance

Muscular endurance is the ability of your muscles to perform muscular activity over a period of time or it is the duration upto which you can apply your muscular strength. Muscular endurance is related with the time and duration of the activity. Slow twitch fiber in muscles is responsible for the activities of muscular endurance. Sometimes, the term stamina is also used in place of endurance.

Tests related to Muscular Endurance

There are many tests to measure muscular endurance. 1000 metre run or walk test is the most common test, which is discussed below.

1000 Metre Run or Walk Test

Through this test, one can identify and assess cardio-vascular endurance.

For this test, one needs running track and a stopwatch.



Procedure

Participants or students should start running from the starting line on the command of teacher. They have to cover the distance of 1000 metre in shortest possible time. Walking is also allowed.

Scoring

The score of this test will be given on the basis of recorded time to cover 1000 meters (in a minute and second).



Fig. 9.4: 1000 metre run or walk test

Flexibility

As discussed in the previous chapter, flexibility is the range of motion around the various joints. Flexibility is the ability of our joints and muscles to perform movements with greater range. Good flexibility helps to execute the movement with less muscle tension.

Test related to flexibility

Sit and Reach Test: Sit and reach test helps in the measurement of flexibility of the lower back muscles and hamstring muscle group. For this test, a sit and reach box, and mat are required.

Procedure

The person is asked to sit in a long sitting position placing both feet against the box with sole touching the box. The knees should be straight, legs should be grounded and palm facing downward on top of each other at same level above the box (Fig. 9.5).

The person is asked to bend forward sliding the hand on the scale without any jerky movement.

Scoring

Score is recorded in centimeters.

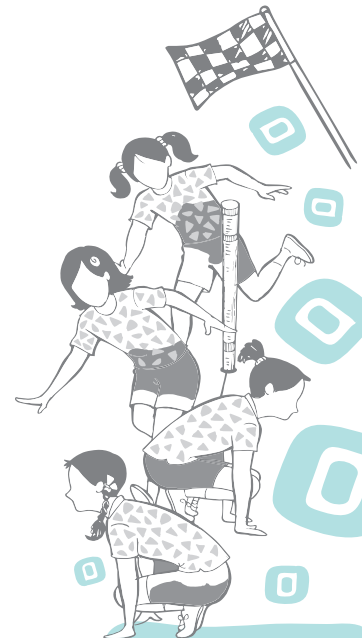

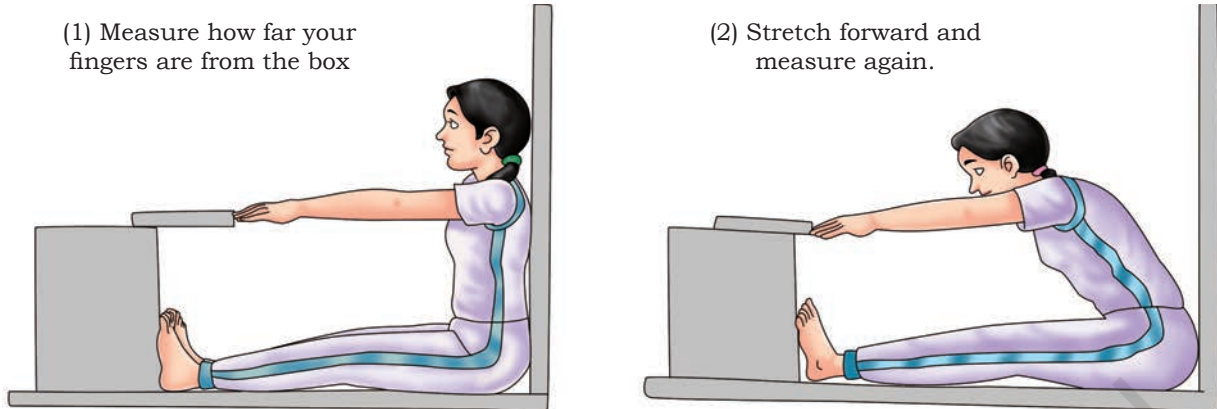

Fig. 9.5: Sit and reach test



Fig. 9.6: Measurement of body weight

Activity 9.5

If there is no Anthropometer or Stadiometer, how can you measure the height? Discuss it in class.

Difference between measurements				
Poor	Fair	Good	Very Good	Excellent
6 in (15 cm)	10 in (25 cm)	12 in (30 cm)	14 in (35 cm)	16 in (40 cm)

Body Mass Index (BMI)

This assessment gives the information of an individual’s level of obesity. BMI is calculated by dividing the weight of a person by the square of his/her height.

Measurement of Body Weight

It can be done with the help of a weighing machine.

Procedure

The individual is asked to stand on the weighing machine. The readings of the machine should be noted. While taking the weight, the individual should wear minimum garments. Reading of the weight should be noted down in Kilograms.

Measurement of Height

It can be done with the help of an Anthropometer or Stadiometer.

Procedure

The subject is asked to stand straight against the wall, with the back and head touching the wall, looking in forward direction. The measuring bar of anthropometric rod should be touched at the highest point of the subject’s head (vertex point). The reading should be noted down in centimeters.

BMI Formula Calculator: $\frac{\text{Weight in Kg}}{(\text{Height in meters})^2}$

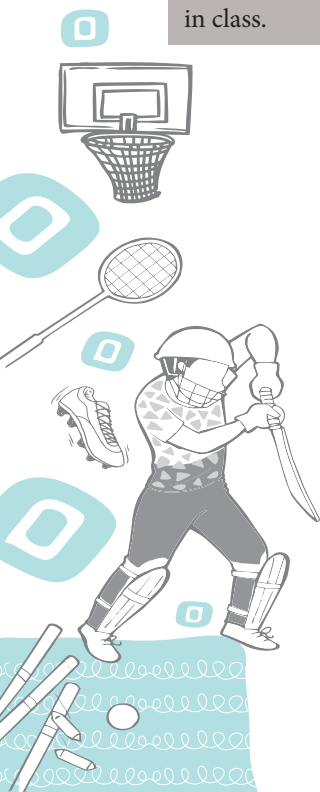

BMI Calculation

BMI is a simple mathematical calculation which helps us to find out if an individual is normal weighted, over weighted or obese. BMI is calculated by dividing the weight of an individual by the square of the height which is expressed in kg/metre^2 . World Health Organization (WHO) has recommended norms for categorising an individual as normal weighted, under weighted or over weighted.

Table 1: BMI Calculation

Category	BMI (kg/m^2)	
	From	To
Very severely underweight	-	15
Severely underweight	15	16
Underweight	16	18.5
Normal (healthy weight)	18.5	24
Overweight	25.0	29.9
Obesity	30 and above	

BMI for children aged between 2 to 20 years is calculated in same way and with the same formula, but not judged on the basis of norms mentioned in the above table. Whatever the result comes after calculating the BMI is compared after preparing the percentile table of all the children falling under the same sex and age category.

Less than 5 percentile is under-weight, 5 to 85 percentile is normal, 85 to 95 percentile is over-weight and above 95 percentile is obese.

Waist-to-hip ratio (WHR)

The waist-to-hip ratio (WHR) helps us to find out the fat distribution by which we can help in evaluating the overall health of an individual. One who carries more weight around the middle than the hip may have higher risk of developing several health issues.

This is the ratio of the circumference of the waist and the circumference of the hip of an individual. This is calculated by dividing waist measurement with the hip measurement of an individual ($W \div H$). For example, if the measurement of the persons waist and hip is 76 cm and 97 cm respectively then his waist-hip ratio will be 0.78.

World Health Organisation (WHO) has recommended the given norms for WHR:

Activity 9.6

Check in which BMI category do you fall. For reference check the textbook of Class IX.



Fig. 9.7: Measurement of body height

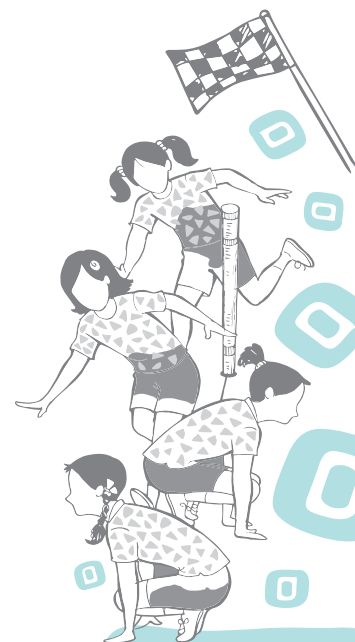

Men	Women	Health risk level
.95 or less	.80 or less	Low risk
.96 to 1.0	.81 to .85	Moderate risk
1.0 or higher	.85 or higher	High risk

Measurement procedure

While taking the measurement of an individual's waist, he/she should be asked to stand straight and breathe out. Then place the tape around the waist just above his or her belly button and take the measurement in centimetres. In the same manner, place the tape around the hip of an individual, where his or her hip is widest then take the measurement.

SOMATO TYPES (ENDOMORPHY, MESOMORPHY AND ECTOMORPHY)

In the 1940s, American Psychologist William Herbert Sheldon developed a theory that there are three body types, or somato types—Endomorph, Mesomorph and Ectomorph. The names were given after the three germ layers of embryonic development; the endoderm (develops into the digestive tract), the mesoderm (becomes muscle, heart and blood vessels), and the ectoderm (forms the skin and nervous system). Each somato type has its own distinct physical characteristics and supposedly distinct personality as well. The unique physical characteristics of each body type are still widely used as an important factor while designing workout routines for the individual.

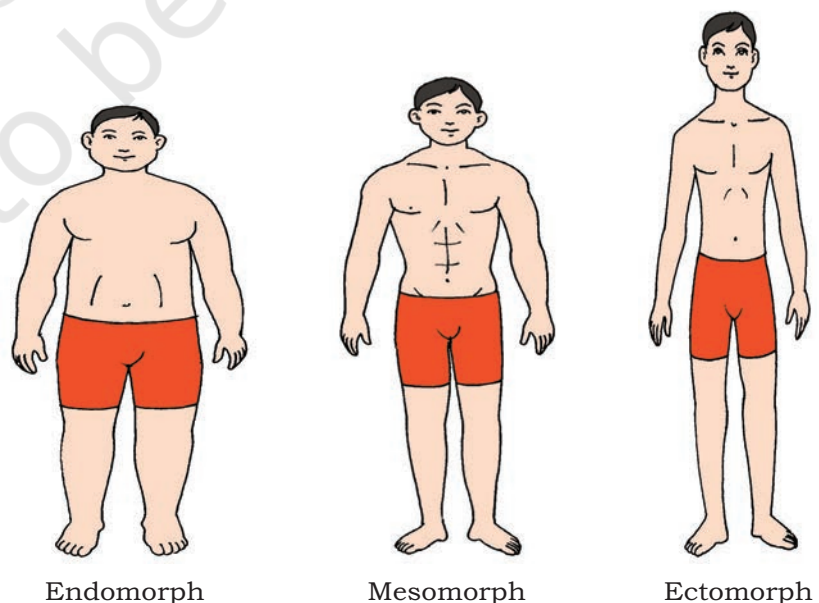
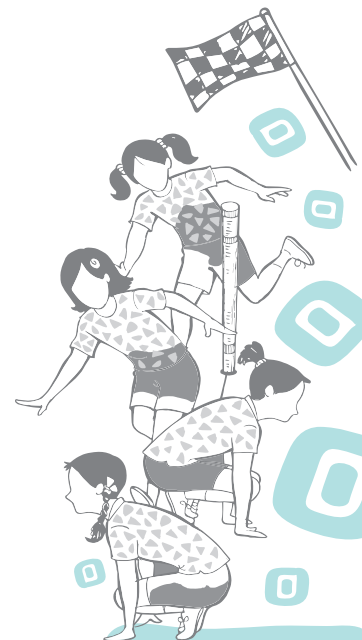

Fig. 9.8: Three body types

1. Endomorph: An endomorphic individual typically has short arms and legs and a large amount of mass on their frame. Their mass hampers their ability to compete in sports requiring high levels of agility or speed and perform sustained weight bearing aerobic activities such as running. Sports of pure strength, like power lifting, are perfect for an endomorph. They can gain weight easily and lose condition quickly if the training stops. Such individuals have:
 - (i) a pear shaped body
 - (ii) a rounded head
 - (iii) wide hips and shoulders
 - (iv) wider front to back rather than side to side
 - (v) a lot of fat on the body, upper arms and thighs
 - (vi) Such individuals are good for sports such as rugby where bulk is useful, provided it can be moved powerfully. They tend to have large lung capacity which can make them suited to sports such as rowing. They can increase muscle mass much more easily than ectomorphs.

2. Mesomorph: A mesomorphic individual excels in strength, agility, and speed related games/sports. Their medium structure and height, along with their tendency to gain muscle and strength easily makes them a strong candidate for a top athlete in any sport. They can sustain low body fat levels and find it easy to lose and gain weight. They have:
 - (i) a wedge shaped body
 - (ii) a cubical head
 - (iii) wide broad shoulders
 - (iv) muscled arms and legs
 - (v) narrow hips
 - (vi) narrow from front to back rather than side to side
 - (vii) minimum amount of fat
 - (viii) Such individuals have sport benefits. They can respond well to cardiovascular and resistance training and can sustain low body fat levels. All the muscle groups can be used by them to derive positive training adoption.
 - (ix) Depending on the sport's needs, they can easily gain or lose weight

3. Ectomorph: A predominantly ectomorphic individual is long, slender and thin, and therefore power and



strength sports are perhaps not suitable as they are more susceptible to injuries. While they can easily get lean and hard, their lack of musculature, severely limits their chances in sports requiring mass. Ectomorphs dominate endurance sports and gymnastics. They can archive low levels of body fat which can be detrimental to health and for females in endurance sports, it can result in a cessation of periods and iron deficiency. Such individuals have:

- (i) a high forehead
- (ii) receding chin
- (iii) narrow shoulders and hips
- (iv) a narrow chest and abdomen
- (v) thin arms and legs
- (vi) little muscle and fat

One can conclude that every individual should try to find out by using these tests to see what types of activities should be done to remain healthy and fit.



ASSESSMENT

I. Long Answer Questions

1. List and explain the tests related to muscular strength.
2. List and explain the tests related to muscular endurance.
3. Write down the procedure of Abdominal Curl-up test.
4. Explain the waist-hip ratio in detail.
5. Explain the three somato types in detail.

II. Short Answer Questions

1. What is test?
2. What is measurement?
3. What is evaluation?
4. What is flexibility?
5. Write down two characteristics of each somato type.

III. Fill in the Blanks

1. _____ is calculated by dividing weight by the square of height.
2. _____ is a tool.
3. Measurement can be _____ or _____ both.
4. Two types of flexibility are _____ flexibility and _____ flexibility.

IV. State whether True or False

1. BMI stands for body measurement index.
2. Flexibility is range of motion around the various joints.
3. Anthropometer or stadiometer is used for measuring weight.
4. The objective of squat thrust is to identify and assess muscular strength and endurance of the lower body.
5. The objective of abdominal curl-up test is to identify and assess the muscular strength and endurance of back muscles.
6. The objective of push-up test is to identify and assess muscular strength and endurance of the upper body.





11152CH10

TOURNAMENTS AND COMPETITIONS

10

Activity 10.1

Collect information about the types of tournaments played at school level in different games and sports.

You may have heard about tournaments that are organised for different sports at different levels. Have you read or heard about world cup tournaments for Cricket, Hockey, Football or Kabaddi? Such tournaments are also held at national and state level and even at local level. You or your friends may have participated in inter-school or other open tournaments for Kabaddi, Kho-Kho, Football, Volleyball, Basketball and Cricket organised at the zone, district or local levels.

A tournament is a competition held among different teams in a particular game or sport according to a fixed schedule where a winner is decided. Different types of tournaments are—Knock-out or Elimination Tournament (Single Knock-out or Single Elimination, Consolation Type I and Type II, C Double Knock-out or Double Elimination), League or Round Robin Tournament (Single League, and Double League), Combination Tournament (Knock-out cum Knock-out, Knock-out cum League, League cum Knock-out, League cum League) and Challenge Tournament (Ladder, and Pyramid).

While deciding the type of tournament to be conducted, the season, time of disposal, play fields and equipment, type of activity, officials, and finance/budget must be taken into consideration.

Different types of tournaments with their merits and demerits, and the method of drawing fixtures have been described in this chapter.

KNOCK OUT OR ELIMINATION TOURNAMENT

Single Knock out or Single Elimination

In single knock out tournament, the teams once defeated, are eliminated and not given another chance to play.



Total number of matches in the tournament = $N - 1$,
where N is the number of teams competing.

For example, if $N = 13$

Total number of matches = $13 - 1 = 12$

Method of Drawing Fixtures

1. Drawing fixture for a certain number of teams competing is decided by the power of two, viz. $2, 2^2, 2^3, 2^4, 2^5, 2^6, \dots$ etc., i.e., $2, 4, 8, 16, 32, 64, \dots$ respectively.
2. Suppose 16 teams have entered for a tournament, there will be no byes i.e. $16 - 16 = 0$.
3. If the number of teams participating is not a power of 2, the byes will be given to a specific number of teams in the first round.
4. The number of 'Byes' to be given is decided by subtracting the number of teams from its next higher number which is the power of two. For example, if 13 teams entered for a competition, number of Byes = $16 - 13 = 3$ and for 25 teams, number of Byes = $32 - 25 = 7$

Seeding

Single Knock out Fixture for 8 Teams

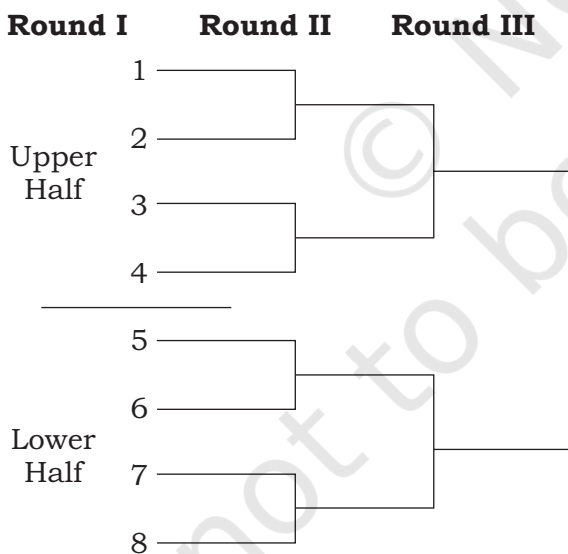

$$\text{Upper Half} = \frac{N}{2} = \frac{8}{2} = 4 \text{ Teams}$$

$$\text{Lower Half} = \frac{N}{2} = \frac{8}{2} = 4 \text{ Teams}$$

$$\text{No. of matches} = N - 1 = 8 - 1 = 7$$

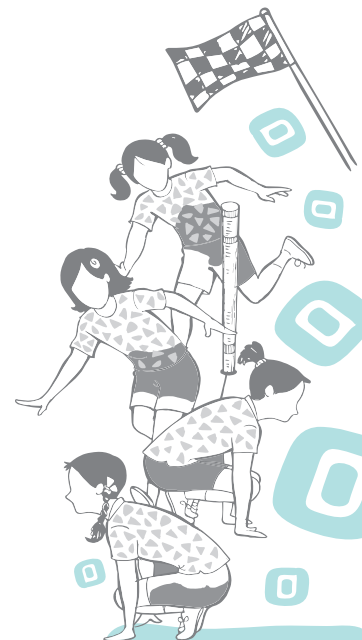

Single Knock out Fixture for 10 Teams

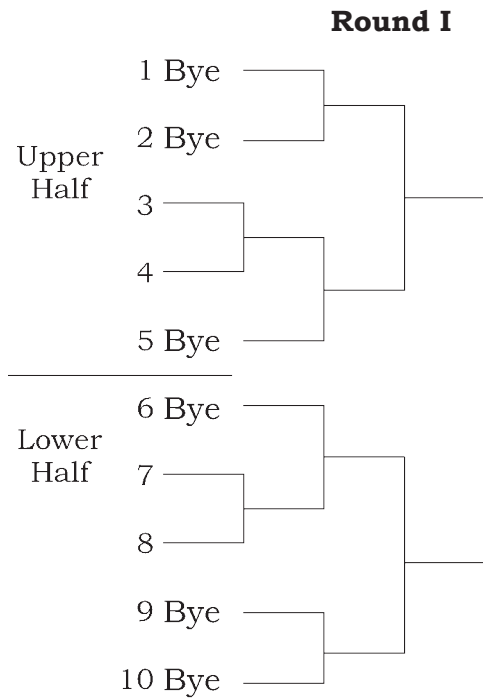

$$\text{Upper Half} = \frac{N}{2} = \frac{10}{2} = 5 \text{ Teams}$$

$$\text{Lower Half} = \frac{N}{2} = \frac{10}{2} = 5 \text{ Teams}$$

$$\text{No. of Byes} = 16 - 10 = 6$$

$$\text{No. of Byes in Upper Half} = \frac{Nb}{2} = \frac{6}{2} = 3$$

$$\text{No. of Byes in Lower Half} = \frac{Nb}{2} = \frac{6}{2} = 3$$

$$\text{No. of matches} = 10 - 1 = 9$$

Single Knock out Fixture for 11 Teams

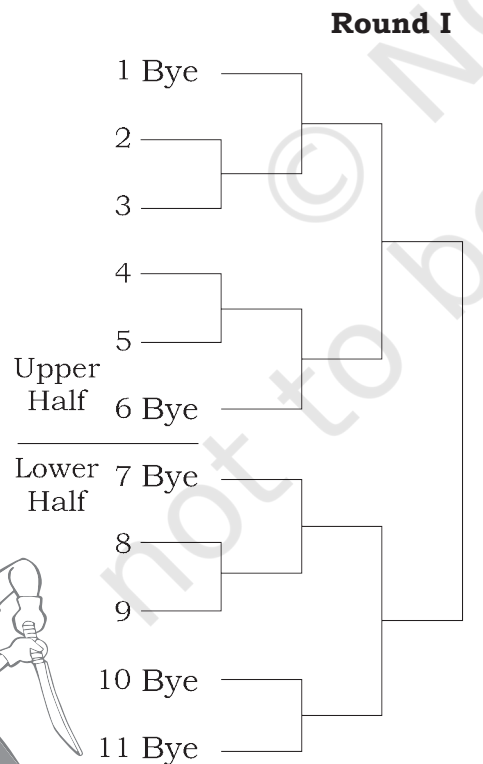

$$\text{Upper Half} = \frac{N+1}{2} = \frac{12}{2} = 6 \text{ Teams}$$

$$\text{Lower Half} = \frac{N-1}{2} = \frac{10}{2} = 5 \text{ Teams}$$

$$\text{No. of Byes} = 16 - 11 = 5$$

$$\text{No. of Byes in Upper Half} = \frac{Nb-1}{2} = \frac{5-1}{2} = \frac{4}{2} = 2$$

$$\text{No. of Byes in Lower Half} = \frac{Nb-1}{2} = \frac{5+1}{2} = \frac{6}{2} = 3$$

$$\text{No. of matches} = N - 1 = 11 - 1 = 10$$



Procedure of giving byes

Ist Bye	—	Bottom of the lower half
IIInd Bye	—	Top of the upper half
IIIrd Bye	—	Top of the bottom half
IVth Bye	—	Bottom of the upper half

This process continues in case the number of byes are more than four.

A knock-out fixture is usually drawn by lots and if it is drawn purely on the basis of lots without considering the standards of the teams, strong teams may meet each other in the earlier rounds, hence allowing the weaker teams reaching upto semifinals resulting in unfair and uninteresting competition. To avoid this, seeding is done. Seeding is sorting of strong teams and fitting them into the fixtures so that these teams do not meet in the earlier rounds.

If there is no marked difference in the standard of the seeded teams, then these teams are distributed in the fixture by lots among them.

Table 1: Number of Teams in each Quarter

Dividend and Divisor	Remainder	No. of teams in each quarter			
		I	II	III	IV
$N \div 4$	0	Q	Q	Q	Q
$N \div 4$	1	Q + 1	Q	Q	Q
$N \div 4$	2	Q + 1	Q	Q + 1	Q
$N \div 4$	3	Q + 1	Q + 1	Q + 1	Q

(N = No. of Teams, Q = Quotient)

No. of Teams/entries	5 to 8 = $2 \times 2 \times 2 = 2^3$ = 3 Rounds
No. of Teams/entries	9 to 16 = $2 \times 2 \times 2 \times 2 = 2^4$ = 4 Rounds
No. of Teams/entries	17 to 32 = $2 \times 2 \times 2 \times 2 \times 2 = 2^5$ = 5 Rounds
No. of Teams/entries	33 to 64 = $2 \times 2 \times 2 \times 2 \times 2 \times 2 = 2^6$ = 6 Rounds
No. of Teams/entries	65 to 129 = $2 \times 2 \times 2 \times 2 \times 2 \times 2 \times 2 = 2^7$ = 7 Rounds

Activity 10.2

- Draw a fixture of nine teams for a Single Knock-out tournament and show it to your teacher.
- Collect information about the rules and regulations for drawing fixtures in Inter School Competitions.

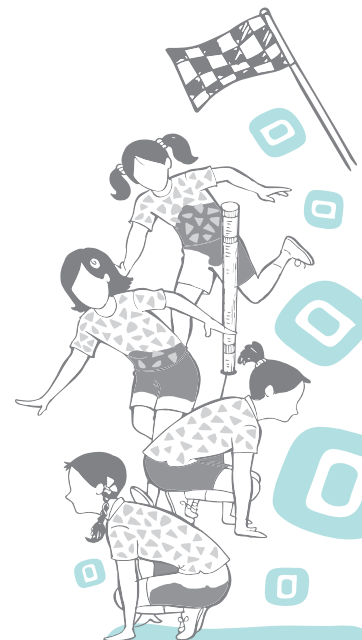

Merits and Demerits of Single Knock out or Elimination Tournament

Merits

- (i) Tournament finishes in a short time.
- (ii) There will be economy of expenditure.
- (iii) The competition will be keen and intense due to the fear of elimination of a team from the tournament, when defeated.

Demerits

- (i) A team may be eliminated by chance and will not get another chance to play.
- (ii) If the fixture is drawn purely by lots, there is a possibility of matches between strong teams in the earlier rounds, which would get eliminated, thus weaker teams reaching Semifinals or the Finals.
- (iii) Winner of a match/round may have to wait for the winner of another match to play the next round.

Special Seeding

When some top ranking players or teams participate in a tournament, the fixtures are generally drawn in such a manner that these players or teams play directly at Quarter Finals or Semifinals stage.

A fixture of 24 teams participating in a tournament including 4 teams, i.e., 1, 12, 13 and 24, are given special seeding direct at the Quarter Finals stage.

For deciding the number of byes for the fixture of special seeding, first subtract the number of teams that are given special seeding (4) from the total number of teams participating (24), i.e., $24 - 4 = 20$.

Now, Number of Byes = $32 - 20 = 12$ Byes.



**Single Knock out Fixture for 24 Teams
(Special Seeding 4 teams)**

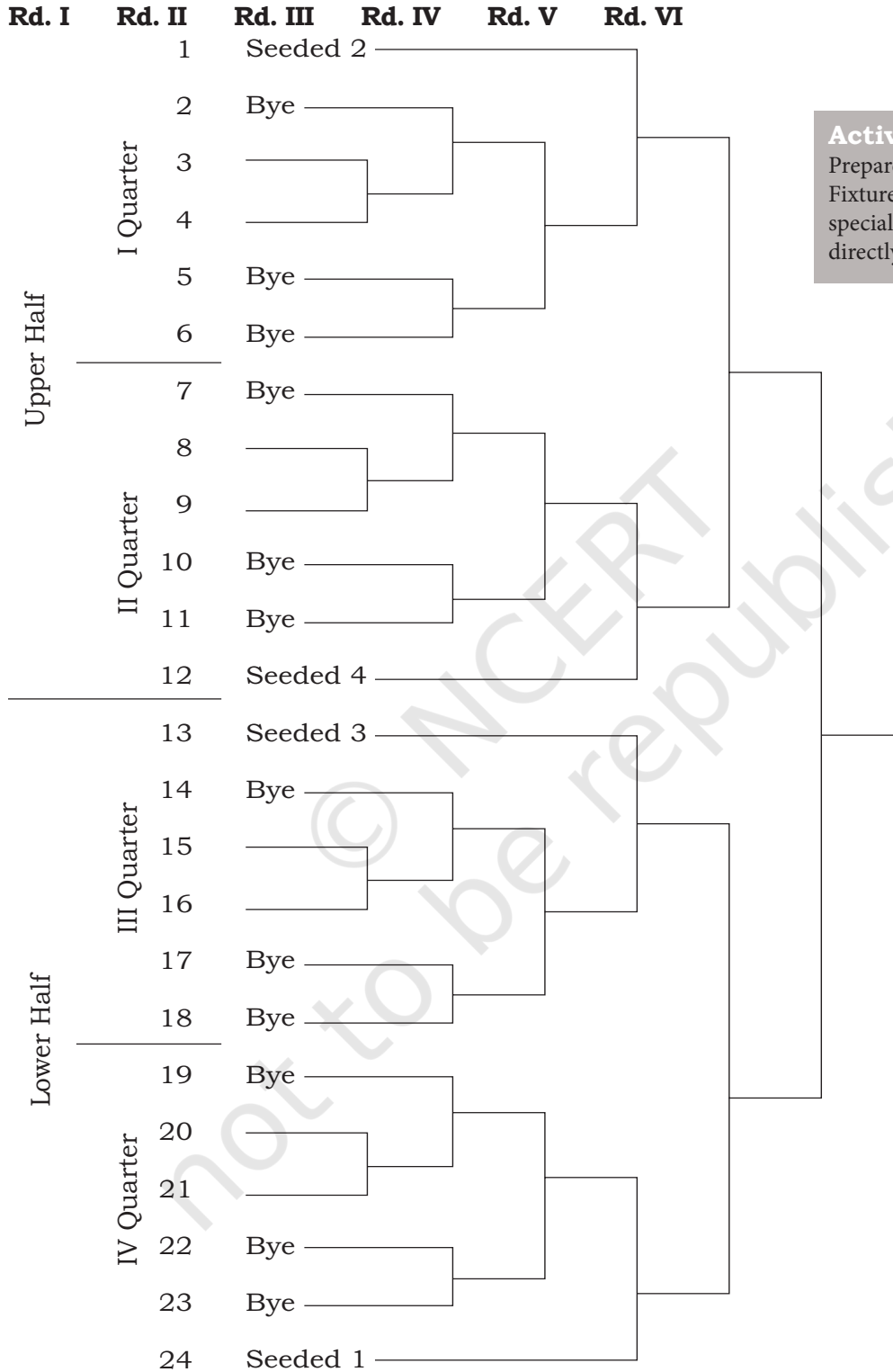

Activity 10.3
Prepare a Single Knock out Fixture for 47 teams with specially seeding four teams directly into Quarter Finals.

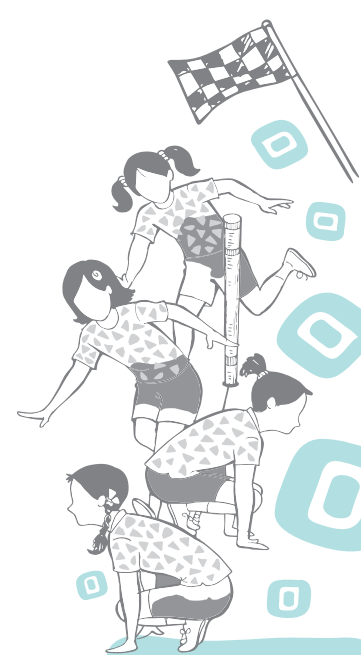

Consolation Tournament

In single knock out or elimination tournament, a team may be eliminated by chance and will not have another chance to play. To avoid this, consolation tournaments are advocated. Consolation indicates that defeated teams would play again to show their worth and win subsidiary honours. Greater number of matches are possible in this tournament, and hence it's superior to single knock out tournament.

Consolation tournament is of two types—

- I Type of Consolation Tournament
- II Type of Consolation Tournament

I Type of Consolation Tournament

1. Each team will have a chance to play atleast twice.
2. Teams first play a regular knock out tournament.
3. Teams that are eliminated in the first match in the regular round will play among themselves in the consolation round for subsidiary honours.

Fixture for 13 teams Regular Round

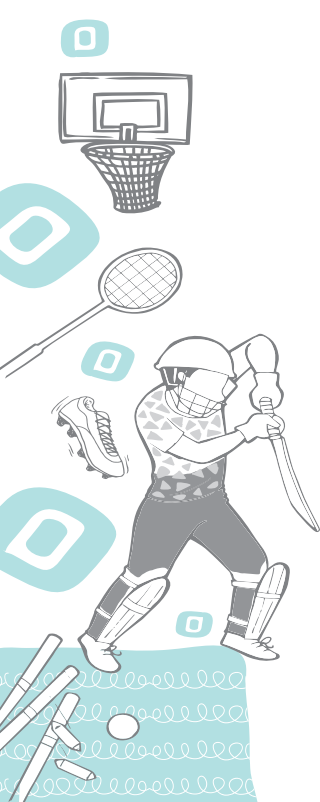
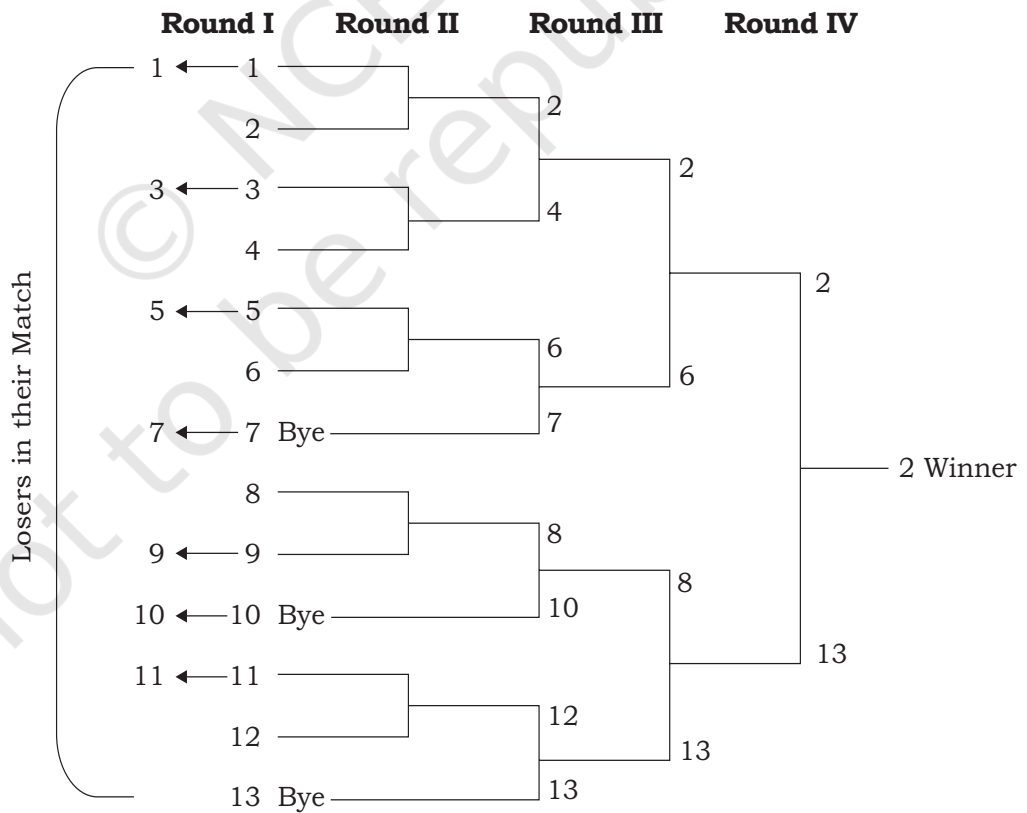

Consolation Round (for losers)

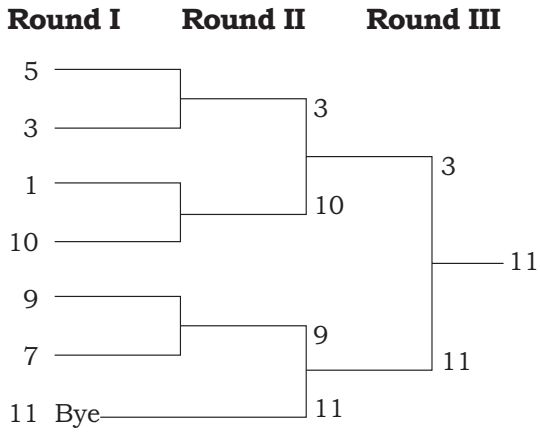

II Type of Consolation Tournament

In II type of consolation tournament, every loser of the regular round will have a chance to play in the consolation round to win subsidiary honours.

Method 1

Fixture for 16 teams (without byes)
Regular round

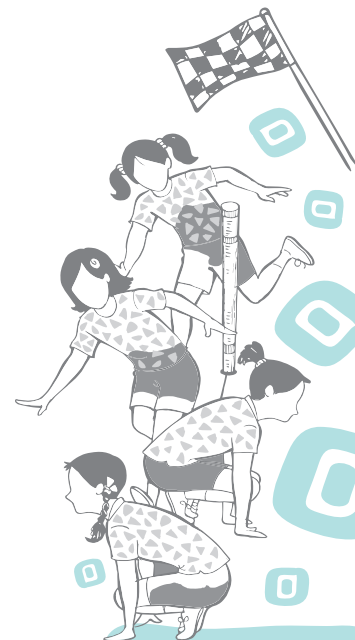
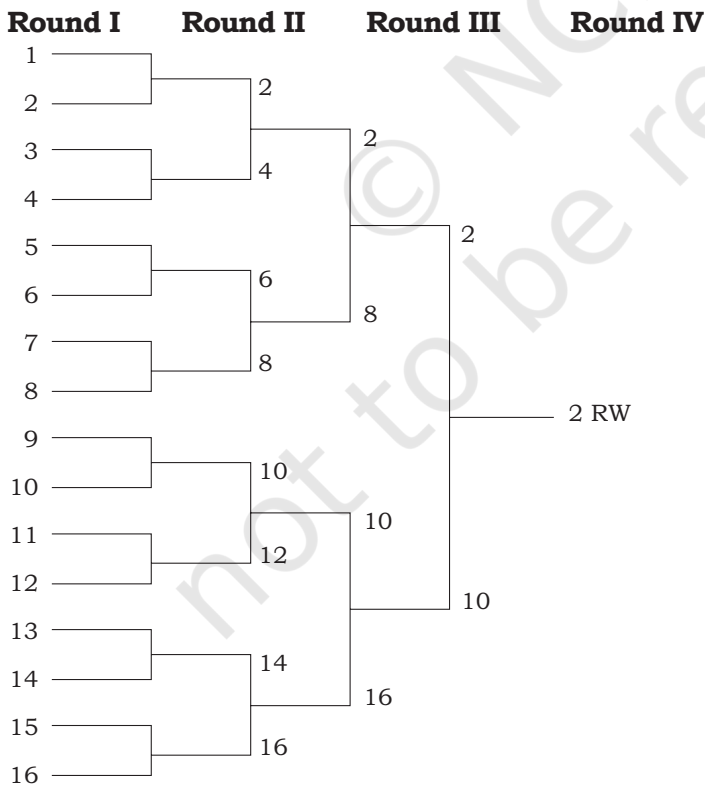

LOSERS

Round I	Round II	Round III	Round IV
1	4	8	10
3	6	16	
5	12		
7	14		
9			
11			
13			
15			

Consolation Round

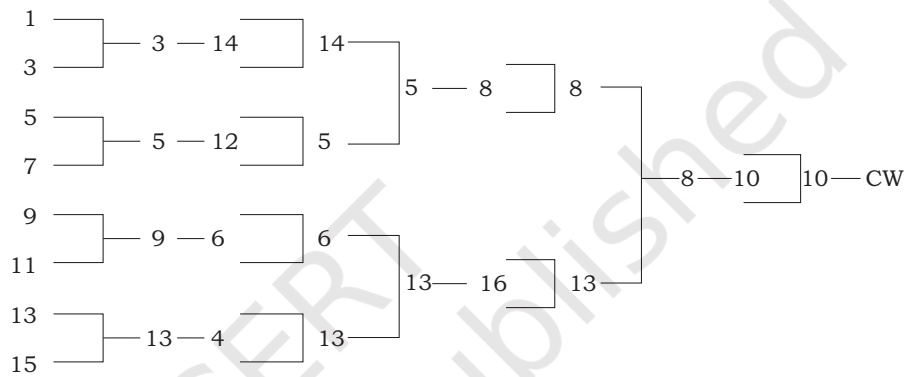

RW — Regular Winner

CW — Consolation Winner

Fixture of 11 teams (with byes)

Regular Round

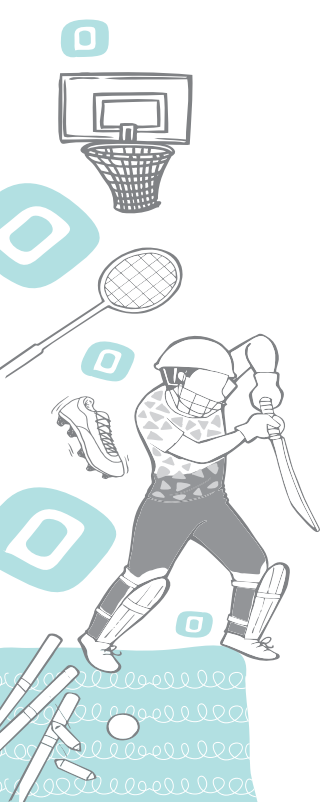
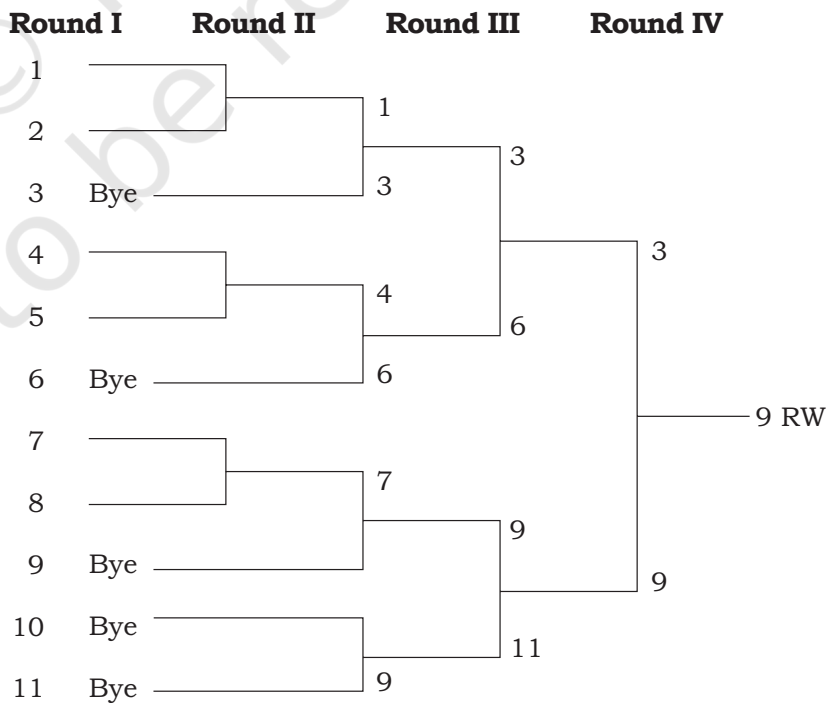

LOSERS

Round I	Round II	Round III	Round IV
2	1	6	3
5	4	11	
8	7		
	10		

Consolation Round

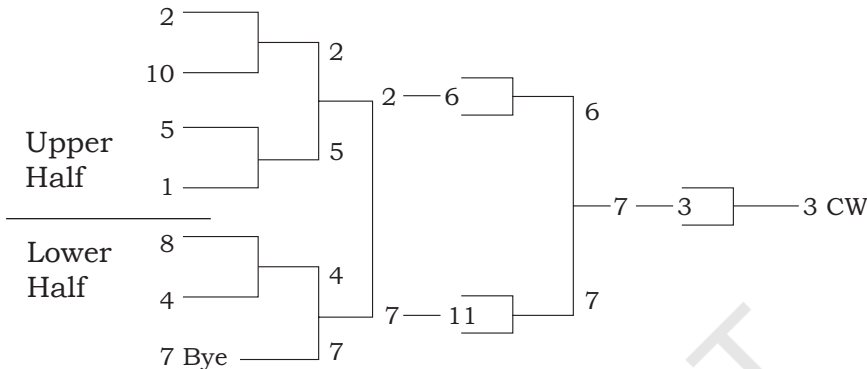

From the two methods of drawing fixtures for the II type of consolation tournaments, the first method is recommended.

Total number of matches to be played in consolation type II = $2N - 3$, where N is the number of participating teams.

Double Knock out or Double Elimination Tournament

- A team must be defeated twice to be eliminated.
- Tournament is continued until all the teams are defeated twice except one team.
- It is superior to single knock-out and consolation tournament because it decides the true winners.
- Double elimination is an extension of consolation type II.
- Regular winner plays with the consolation winner to decide the champion.
- Total number of matches in this tournament shall be $(2n - 2)$ or $(2n - 1)$.

Fixture for 10 Teams (consolation round)

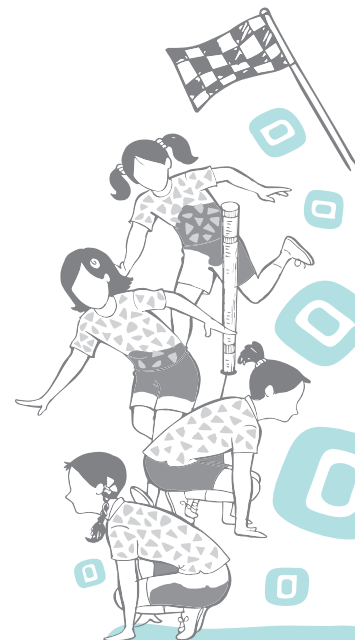
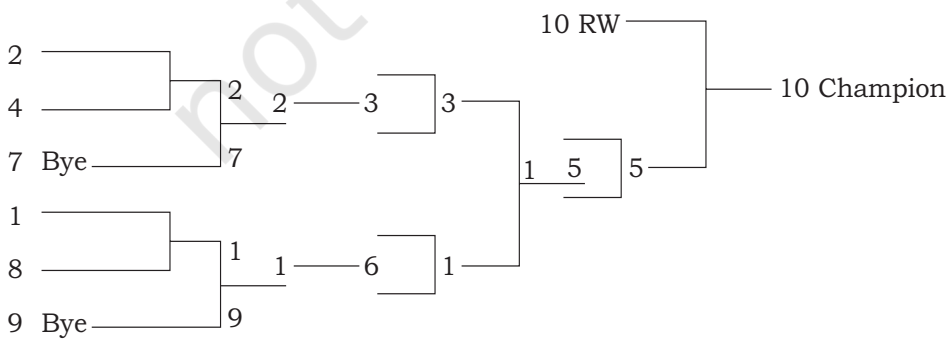

Fixture for 10 Teams (Regular Round)

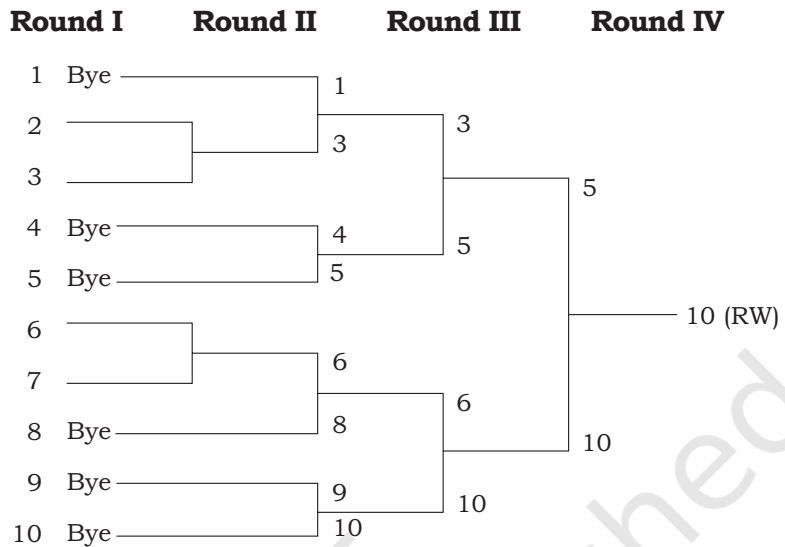

(If number 5 wins instead of number 10, then they will have to play again to decide the champion because both the numbers 5 and 10 have been defeated only once.)

Bagnall-wild Elimination Tournament

This tournament can truly decide the first three places.

Fixture for 12 Teams (regular round)

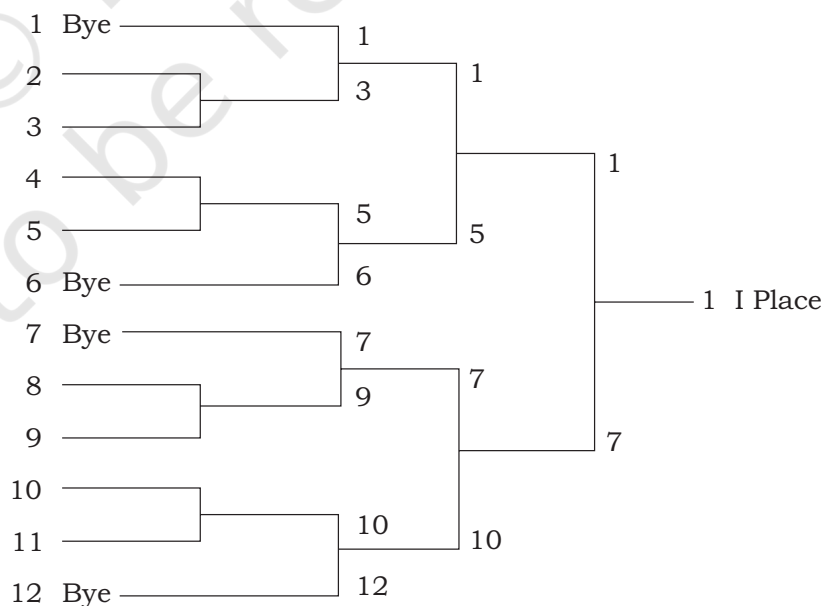

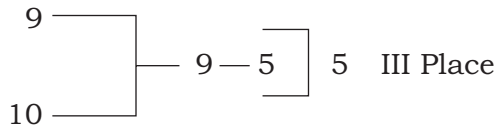
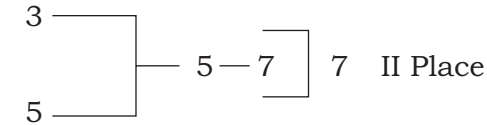
Fixture for 12 Teams (consolation round)

In the above fixture of 12 teams, the first 3 places are decided as follows—

First place: Winners of the regular knock out tournament gets first place.

Second place: All the teams defeated by first place winner except the defeated finalist play among themselves on knock out basis and their winner plays with the defeated finalist. The winner of this match gets second place.

Third place: All the teams defeated by the runner ups of the regular tournament play among themselves on knock out basis and the winner plays with the loser of the final round for second place. The winner of this match gets third place.

Note: If number 5 gets second place instead of number 7. Third place will automatically be accorded to number 7 (without any further matches).

League or Round Robin Tournament

- (a) Single League: In Single League tournaments, each team play once with every other team.

Total no. of Matches in Single League = $\frac{N(N-1)}{2}$, here

N is number of teams.

For example, if 7 teams are competing, the total number of matches will be = $\frac{7(7-1)}{2} = 21$

Merits

- (i) It decides the true winner.
- (ii) Teams play more number of matches.
- (iii) It helps in ranking the participating teams.
- (iv) The teams need not wait for the completion of other matches or rounds.

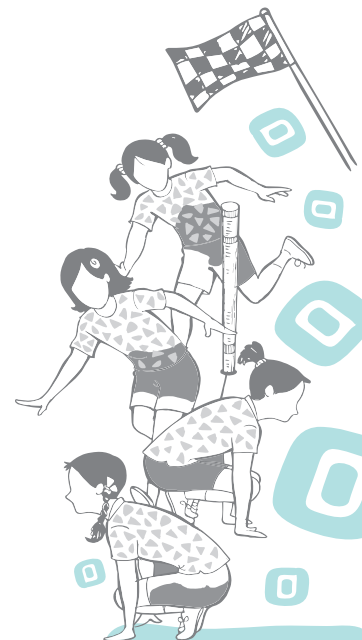

Demerits

- (i) It requires a lot of time and facilities.
 - (ii) Teams that get defeated often will lose interest in the game.
- b. Double League: In double league, every team plays twice with every other team.
- Total number of matches in Double League = $N(N - 1)$, where N is the number of teams participating in a tournament.

Method of Drawing Fixture for Single League

Cyclic Method

Fixture of 5 teams

$$\text{No. of Matches} = \frac{N(N-1)}{2} = \frac{5(5-1)}{2} = 10$$

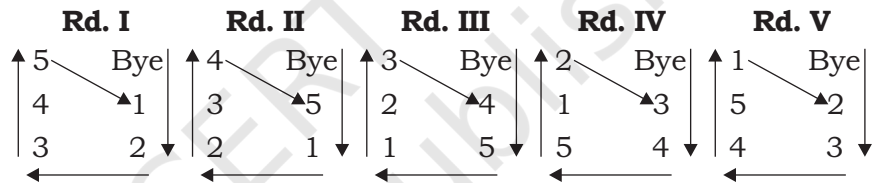

Fixture of 6 teams

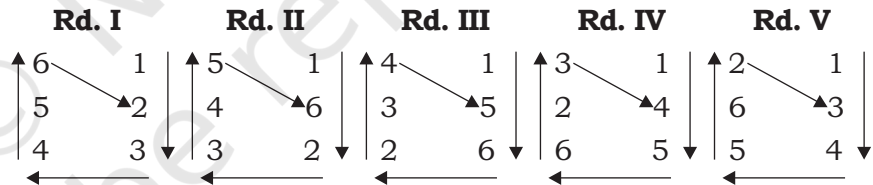

For drawing fixture by Cyclic Method, fix number. 1 in case of even number of teams and fix Bye in case of odd number of teams and rotate the other numbers clockwise as shown in the above fixture.

Total number of rounds for even number of teams = $N - 1$ rounds

Total number of rounds for odd number of teams = N rounds,

where N is the number of teams

Tabular Method

In this method, the fixtures are drawn in a tabular form. The numbers of columns to be drawn horizontally as well as vertically are—

- a) For even number of teams, $N+1$ columns
- b) For odd number of teams, $N+2$ columns

Procedure for entering the numbers inside the squares indicating the rounds—

- (i) In the squares of the horizontal columns immediately below the teams, enter the numbers serially from number 1 onwards.
- (ii) In each vertical column except the last one, enter the numbers serially starting from the number next to that round at the teams.

Fixture of 8 teams

	A	B	C	D	E	F	G	H
A		1	2	3	4	5	6	7
B			3	4	5	6	7	2
C				5	6	7	1	4
D					7	1	2	6
E						2	3	1
F							4	3
G								5
H								

$$\text{No. of Matches} = \frac{N(N-1)}{2} = \frac{8(8-1)}{2} = 28$$

Rd. I	Rd. II	Rd. III	Rd. IV	Rd. V	Rd. VI	Rd. VII
AB	AC	AD	AE	AF	AG	AH
DF	BH	BC	BD	BE	BF	BG
CG	DG	EG	CH	CD	CE	CF
EH	EF	FH	FG	GH	DH	DE

- (iii) Note the number entered in the top square of the last vertical column. In the next square, enter 2. Then precede entering numbers in the other squares every time adding 2, i.e., 4, 6, etc., until the number becomes 1 less than the number at the top-most square.
- (iv) After this, enter number 1, 3, 5, etc., i.e., by 2 every time until the bottom-most square is filled up.
- (v) The number of bottom-most square will be 2 less than the number of the top-most square.

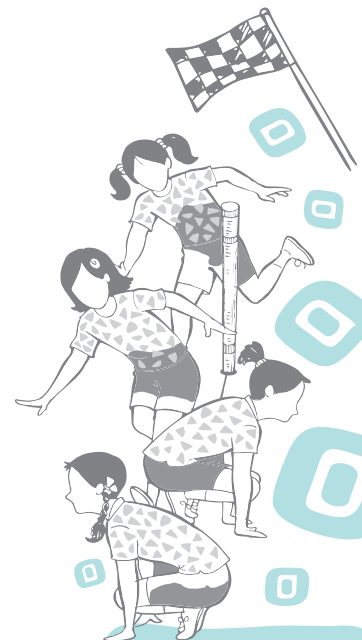

Activity 10.4

- Prepare a fixture for Classes VI to IX for Single League Inter Class tournament and show it to your teacher.
- Collect information about a game played on Single League basis. Also try to understand the rules to decide the winner and discuss it without your teacher.

Fixture of 7 teams

	A	B	C	D	E	F	G	Bye
A		1	2	3	4	5	6	7
B			3	4	5	6	7	2
C				5	6	7	1	4
D					7	1	2	6
E						2	3	1
F							4	3
G								5
Bye								

$$\text{No. of Matches} = \frac{N(N-1)}{2} = \frac{7(7-1)}{2} = 21$$

Rd. I	Rd. II	Rd. III	Rd. IV	Rd. V	Rd. VI	Rd. VII
AB	AC	AD	AE	AF	AG	DE
CG	DG	BC	BD	BE	BF	BG
DF	EF	EG	FG	CD	CE	CF
E Bye	B Bye	F Bye	C Bye	G Bye	D Bye	A Bye

Staircase Method**Fixture of 7 teams by staircase method**

1—2						
1—3	2—3					
1—4	2—4	3—4				
1—5	2—5	3—5	4—5			
1—6	2—6	3—6	4—6	5—6		
1—7	2—7	3—7	4—7	5—7	6—7	

Drawbacks of staircase method

- It does not indicate the number of rounds to be played.
- It is not easy to fix the matches of rounds.

Method of deciding winners in league tournaments

The winners in league tournaments are generally decided on the basis of points scored by the respective teams.



Generally, points awarded are:

Win = 2 points

Loss = 0 points

Draw = 1 points to each team

Team getting maximum number of points is declared the winner.

In case of a tie between two or more number of teams, the ranking is established according to rules and regulations of the International/National Federation of that game or as decided by the Tournament Authorities prior to the commencement of the tournament.

Combination Tournament

- Combination tournaments are usually conducted whenever the matches are to be played on group basis or zonal basis.
- Combination tournaments are highly recommended for conducting Inter-School tournaments in a district, state or zone to save time and money.

a. Knock-out cum Knock-out

(Four zones or Groups A, B, C, D)

Zonal or Group Knock out

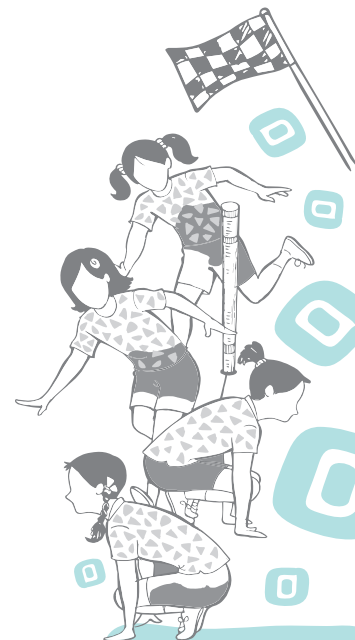
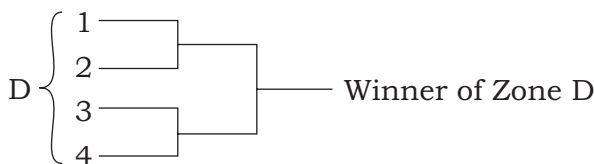
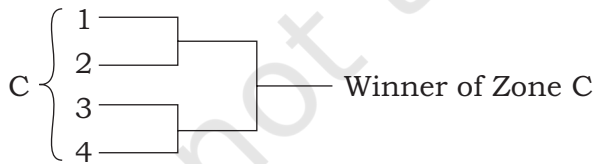
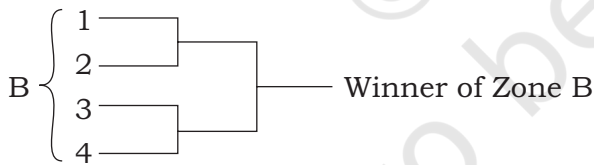
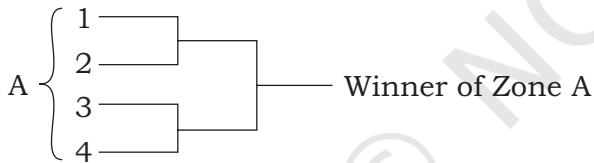

Inter Zonal or Group Knock out

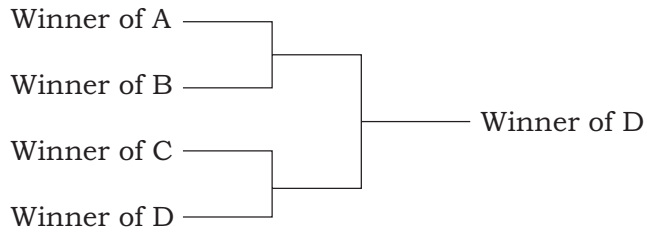

b. Knock-out cum League

(Four zones or Groups A, B, C, D)

Zonal or Group Knock out

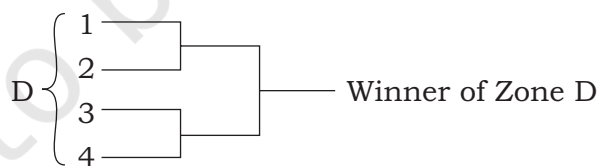
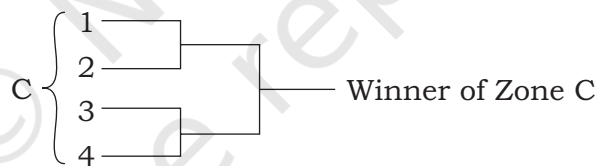
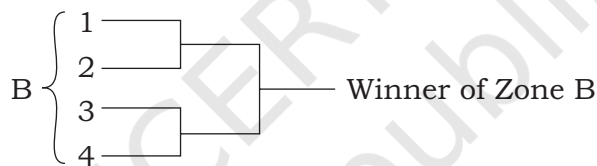
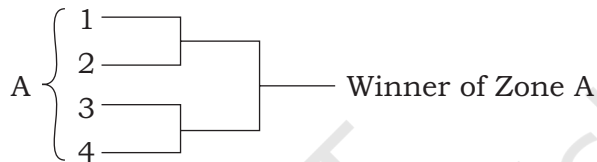

Inter Zonal or Inter Group League

- AB
- AC BC
- AD BD CD

c. League-cum-League

(For Zones or Groups A, B, C, D)



Zonal or Group League

$$A \left\{ \begin{array}{l} 1-2 \\ 1-3 \quad 2-3 \\ 1-4 \quad 2-4 \quad 3-4 \end{array} \right\} \text{ Winner of Zone A}$$

$$B \left\{ \begin{array}{l} 1-2 \\ 1-3 \quad 2-3 \\ 1-4 \quad 2-4 \quad 3-4 \end{array} \right\} \text{ Winner of Zone B}$$

$$C \left\{ \begin{array}{l} 1-2 \\ 1-3 \quad 2-3 \\ 1-4 \quad 2-4 \quad 3-4 \end{array} \right\} \text{ Winner of Zone C}$$

$$D \left\{ \begin{array}{l} 1-2 \\ 1-3 \quad 2-3 \\ 1-4 \quad 2-4 \quad 3-4 \end{array} \right\} \text{ Winner of Zone D}$$

Inter Zonal or Inter Group League

$$\begin{array}{lll} A-B & & \\ A-C & B-C & \\ A-D & B-D & C-D \end{array}$$

d. League-cum-Knock-out

(For Zones or Groups A, B, C, D)

Zonal or Group League

$$A \left\{ \begin{array}{l} 1-2 \\ 1-3 \quad 2-3 \\ 1-4 \quad 2-4 \quad 3-4 \end{array} \right\} \text{ Winner of Zone A}$$

$$B \left\{ \begin{array}{l} 1-2 \\ 1-3 \quad 2-3 \\ 1-4 \quad 2-4 \quad 3-4 \end{array} \right\} \text{ Winner of Zone B}$$

$$C \left\{ \begin{array}{l} 1-2 \\ 1-3 \quad 2-3 \\ 1-4 \quad 2-4 \quad 3-4 \end{array} \right\} \text{ Winner of Zone C}$$

$$D \left\{ \begin{array}{l} 1-2 \\ 1-3 \quad 2-3 \\ 1-4 \quad 2-4 \quad 3-4 \end{array} \right\} \text{ Winner of Zone D}$$

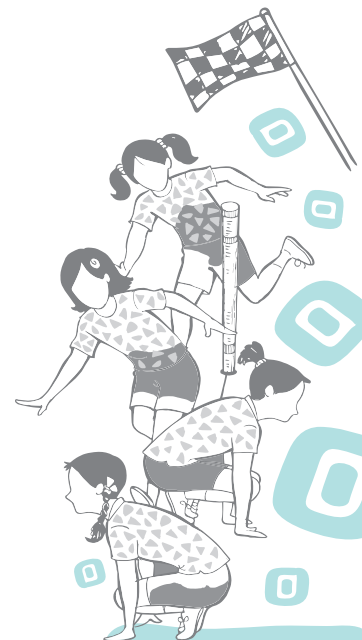

Inter Zonal or Inter Group Knock out

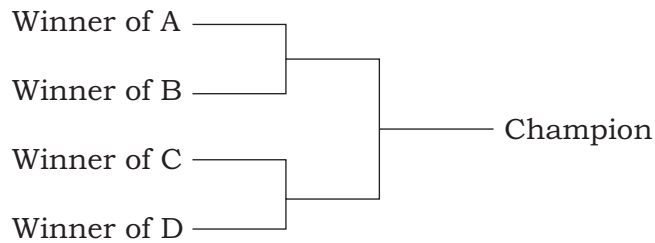

Challenge Tournaments

- Challenge tournaments are usually conducted for games like Badminton, Table Tennis, Squash, etc.
- Challenge tournaments can be carried out during any specified period of time without any fixed schedule.
- This tournament helps in selecting the best players in individual or dual games.

Two common types of challenge tournaments are:

- Ladder Tournament
- Pyramid Tournament

Ladder Tournament

Before starting the ladder tournament, the players shall be arranged in a ladder arbitrarily. Certain rules are followed in the conduct of the tournaments.

1. The period within which the tournament is to be finished is specified.
2. A player can challenge only the player immediately above him. For example, N can challenge any one of the two or three players above him.
3. Challenge must be accepted and played only in the order they are made.
4. The time to play the accepted challenge should be specified.
5. After the challenge match, if the challenger has defeated the player he challenged, the challenger is placed above the loser in the ladder. If not, their original position remains in the ladder.
6. The players who have already played a challenge shall not be allowed to play or challenge again.
7. No excuse after the challenge for a failure is accepted.
8. At the end of the specified period of the tournament, the player remaining on the top of the ladder is declared the winner or the best.

X
Z
C
B
A
M
N
R
S



Pyramid Tournament

1. Pyramid tournament is a modified form of ladder tournament.
2. Players are arranged in the form of a pyramid arbitrarily.
3. Players of a particular rank can challenge any one of the players in the rank immediately above him provided he has challenged the players of his own rank and won. For example, H in rank 4 can challenge C or M or L in rank 3 only after he has challenged and won against K or F or S in his own rank.

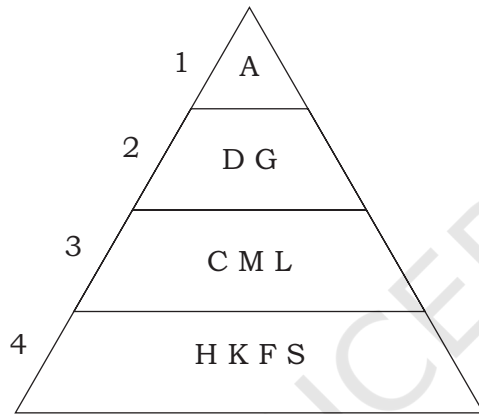

COMPETITIONS

Participation in international sports competitions like Olympic Games, Asian Games and Commonwealth Games help people to know each other and provide opportunities to the participants to see others. It promotes friendship among people of all the continents.

Importance of sports participation in international competitions

1. Participation in sports develops unity of mind and body by which optimum health is achieved.
2. It helps in promoting social peace and justice.
3. It helps in promoting social democracy.
4. It helps in breaking the barriers between social classes and nations.

There are different types of competitions being organised at International, National, State or Zone and University levels. These competitions are being discussed here.

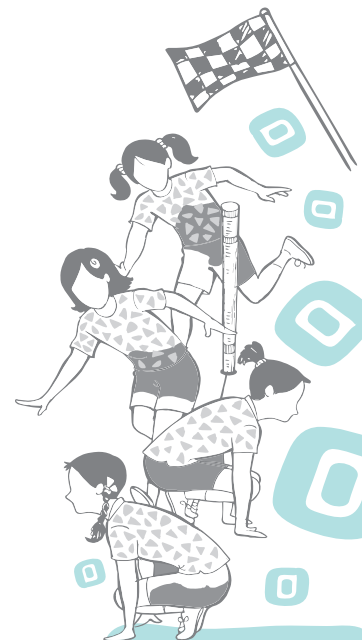

Ancient Olympic Games

First Ancient Olympic Games were held in 776 B.C. These games were regularly held once in four years. A sequence of 293 Olympics was terminated in 394 A.D. by the Roman Emperor Theodosius.

Modern or Summer Olympic Games

Baron Pierre de Coubertin was the founder of the Modern Olympic Games. Modern Olympic Games are also held once in four years and were first held in Athens (Greece) in 1896. But during the two world wars, the Olympic Games (i.e., VIth, XIIth and XIIIth Olympiads respectively in the year 1916, 1940 and 1944) were not held.

International Olympic Committee is the supreme controlling body of the Modern Olympic Games which was formed in Paris on 25th June 1894 with its headquarter in Lausanne (Switzerland). IOC is a permanent and self-elected body, which has at least one member from each country that has National Olympic Committee. From India, Sir Dorabji Jamshedji Tata, G.D. Sondhi and Raja Bhalindera Singh had the honour of being members of IOC.

India first participated in the Olympic Games in 1900 with Norman Pitchard winning two Silver Medals in 200 m and 200 m hurdles. Indian Men's Hockey team has won 8 gold medals (six successive gold from 1928–1956, 1964 and 1980), 1 silver medal (1960 Rome Olympic games) and 2 bronze medals (1968, Mexico and 1972, Munich Olympic games).

In 1952 Helsinki (Finland) Olympic Games, Khashaba Jadhav won bronze medal in Men's Freestyle Bantamweight category in Wrestling. In 1996 Atlanta (USA) Olympic Games, Leander Paes won bronze medal in Men's Singles event in tennis.

In 2000 Sydney (Australia) Olympic Games, Karnam Malleswari won bronze medal in Women's Weightlifting 69 kg weight category. In 2004 Athens (Greece) Olympic Games, Rajyavardhan Singh Rathore won Silver medal in men's double trap in Shooting. In 2008 Beijing (China) Olympics, India won 1 gold medal (Abhinav Bindra in Men's 10 m Air Rifle Shooting) and 2 bronze (Vijender Singh in Middle weight, 75 kg category in Boxing and Sushil Kumar in Men's freestyle, 66 kg category in Wrestling).

In 2012 London (Britain) Olympic Games, India won 2 silver medals (Vijay Kumar in Men's 25 m rapid fire pistol in Shooting and Sushil Kumar in Men's freestyle 66 kg weight category in Wrestling) and 4 bronze medals (Gagan Narang



in Men's 10 m Air Rifle Shooting, Saina Nehwal in Women's Singles in Badminton, Mary Kom in Women's Flyweight category in Boxing and Yogeshwar Dutt in Men's Freestyle 60 kg weight category in Wrestling). In 2016 Reo de Janeiro (Brazil), India won 1 silver medal (Pusarla Venkata Sindhu in Women's Singles event in Badminton) and 1 bronze medal (Sakshi Malik in Women's freestyle 58 kg in Wrestling). In 2020, Olympic Games will be held at Tokyo (Japan), 2024 Games at Paris (France) and 2028 Games will be held at Los Angeles (USA).

Winter Olympic Games

The Winter Olympic Games started in Chamonix (France) in 1924. Winter sports like Figure Skating, Ice Hockey, Ski Jumping, Speed Skating, Alpine Skiing, Freestyle Skating are included in Winter Olympic Games. In 2018, Winter Olympic Games were held at Pyeongchang (Korea) and 2022 Winter Olympic Games will be held at Beijing (China).

Paralympic Games

Paralympic Games are the international competitions specially organised for para athletes. In other words, we can say that "These are the special Olympic Games organised for para athletes. Paralympic Games started in Rome (Italy) in 1960. In Paralympic sports, athletes who participate are grouped into different categories, based on their type of disability such as Physical Impairment, Visual Impairment and Intellectual Disability. In 2016 Paralympic Games in Reo de Janeiro (Brazil), India won 2 gold medals (Mariyappan Thangavelu in Men's High Jump and Devendra Jhajharia in Men's Javelin), 1 silver medal (Deepa Malik in Women's Shot Put) and 1 bronze medal (Varun Singh Bhati in Men's High Jump). The International Paralympic Committee (IPC) is the global governing body of the paralympic movement. Its purpose is to organise the summer and winter Paralympic Games and act as the International Federation for ten sports, supervising and coordinating World Championships and other competitions."

Founded on 22 September, 1989 as a non-profit organisation, it is based in Bonn, Germany and aims to develop sports opportunities for all the people with impairment from the beginner to elite level.

Till 2016, the Summer Paralympic Games included 22 sports and 526 medal events, and the Winter Paralympic Games included 5 sports and disciplines and about 72 events. The number and types of events change from one Paralympic Game to another.

Activity 10.5

Collect photographs of Summer and Paralympic medal winners of India. Prepare a collage with caption. Share it with your classmates.

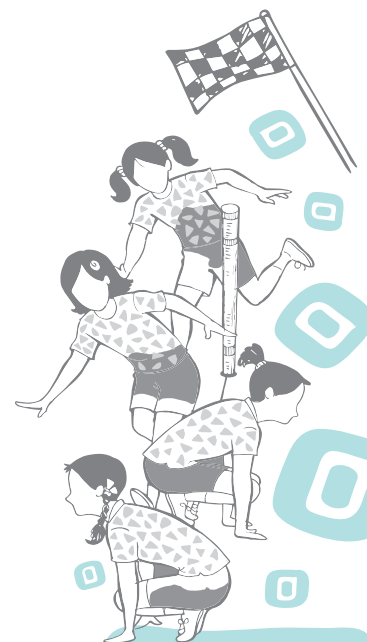

Commonwealth Games

Melville Marks Robinson was the founder of the Commonwealth games. The First Commonwealth games were held in 1930 in Hamilton (Canada). Since then, the Commonwealth Games have been conducted every four years except for 1942 and 1946 due to World War II. From 1930 to 1950, the games were known as the British Empire Games. From 1954 to 1966, the games were called the British Empire and Commonwealth Games and from 1970 to 1974, the games were termed as the British Commonwealth Games. It was from 1978 Edmonton (Canada) Games onwards, these are known as the Commonwealth Games.

India's Performance in Commonwealth Games

Year	Edition	Venue	Medals				Rank
			Gold	Silver	Bronze	Total	
2018	XXI	Gold Coast (Australia)	26	20	20	66	3rd
2014	XX	Glasgow (Scotland)	15	30	19	64	4th
2010	XIX	Delhi (India)	38	27	36	101	3rd
2006	XVIII	Melbourne (Australia)	22	17	11	50	4th
2002	XVII	Manchester (England)	30	22	17	69	4th
1998	XVI	Kuala Lumpur (Malaysia)	7	10	8	25	7th
1994	XV	Victoria (Canada)	6	11	7	24	6th
1990	XIV	Auckland (New Zealand)	13	8	11	32	5th
1986	XIII	Edinburgh (Scotland)	Did not participate				
1982	XII	Brisbane (Australia)	5	8	3	16	6th
1978	XI	Edmonton (Canada)	5	5	5	15	6th
1974	X	Christchurch (New Zealand)	4	8	3	15	6th



1970	IX	Edinburgh (Scotland)	5	3	4	12	6th
1966	VIII	Kingston (Jamaica)	3	4	3	10	8th
1962	VI	Perth (Australia)	Did not participate				
1958	VI	Cardiff (Wales)	2	1	0	3	8th
1954	V	Vancouver (Canada)	0	0	0	-	-
1950	IV	Auckland (New Zealand)	Did not participate				
1946	Not held due to World War II						
1942							
1938	III	Sydney (Australia)	0	0	0	-	-
1934	II	London (England)	0	0	1	1	12th
1930	I	Hamilton (Canada)	Did not participate				

Asian Games

The inaugural Asian Games were held in New Delhi, India in 1951. The Asian Games, also known as Asiad are held every four years. 2018 Asian Games were held at Palembang, Jakarta (Indonesia). 2022 Asian Games will be conducted in Hangzhou (China).

India's Performance in Asian Games

Year	Edition	Venue	Medals				Rank
			Gold	Silver	Bronze	Total	
2018	XVIII	Palembang, Jakarta (Indonesia)	15	24	30	69	8th
2014	XVII	Incheon (Korea)	11	9	37	57	8th
2010	XVI	Guangzhou (China)	14	17	34	65	6th
2006	XV	Doha (Qatar)	10	17	26	53	8th
2002	XIV	Busan (South Korea)	11	12	14	37	7th

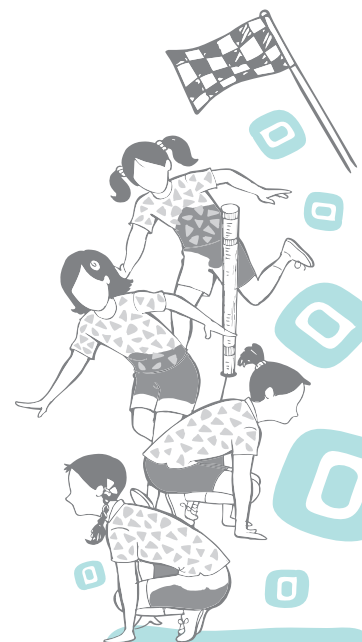

1998	XIII	Bangkok (Thailand)	7	11	17	35	9th
1994	XII	Hiroshima (Japan)	4	3	16	23	8th
1990	XI	Beijing (China)	1	8	14	23	11th
1986	X	Seoul (South Korea)	5	9	23	37	5th
1982	IX	New Delhi (India)	13	19	25	57	5th
1978	VIII	Bangkok (Thailand)	11	10	7	28	6th
1974	VII	Tehran (Iran)	4	12	11	27	7th
1970	VI	Bangkok (Thailand)	6	9	10	25	5th
1966	V	Bangkok (Thailand)	7	3	11	21	5th
1962	IV	Jakarta (Indonesia)	10	9	11	30	3rd
1958	III	Tokyo (Japan)	5	4	5	14	7th
1954	II	Manila (Philippines)	5	4	8	17	5th
1951	I	New Delhi (India)	17	17	18	52	2nd

National Games

Early National Games termed as Indian Olympic Games started in 1924 at Lahore. The games were held every two years. Indian Olympic Games were renamed as National Games from the IX Games in Bombay in 1940. National Games on the lines of the Olympic Games started in 1985 in Delhi. Last National Games were held at Thiruvananthapuram (Kerala) in 2015.

National Championships

National Sports Associations and Federations conduct the National Championships in their game or sport every year. National Federations conduct National Championships in Mini, Sub Junior, Junior, Youth, Senior and Veteran categories in boys/men as well as girls/women section.



National Championships in different individual games like Badminton, Table Tennis, etc., are conducted for individual events as well as team events. In games like Wrestling, Judo, etc., National Championships are conducted in different weight categories by the concerned National Associations or Federations.

Inter University Tournaments

Inter University Tournaments in India started in 1941. Sports Department of Indian Universities allocates the tournaments to different universities for organising inter-university tournaments in different games and sports for participation of University students. The tournaments are organised annually on all India basis/4 zone basis and played on Knock-out/League/League cum Knock-out basis. Only member universities/institutes of the association are eligible to enter their teams to participate in the Inter University tournaments, with only one team from each university.

SGFI Games

School Games Federation of India (SGFI) is a voluntary organisation which was formed in December, 1954 to promote games and sports for boys and girls at National and International level. Different States and affiliated units participate in National School Games organised every year. It conducts competitions at National level for various games and sports like Athletics, Badminton, Football, Wrestling, Kabaddi, Table Tennis, etc. Competitions are organised for different age groups i.e. (U-14, U-17 and U-19). Only school boys and girls below 19 years can participate in these games.

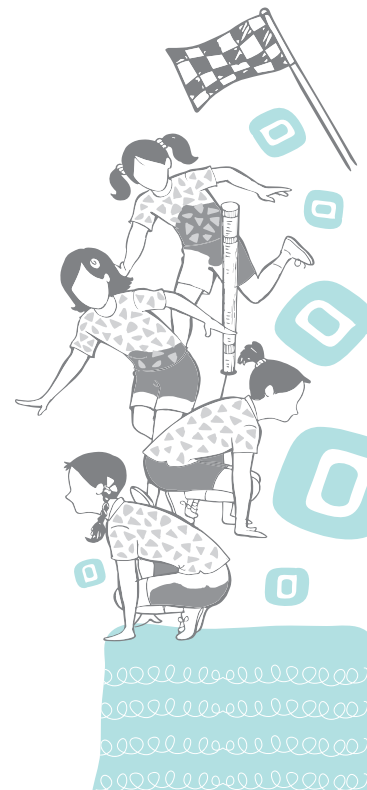

ASSESSMENT

I. Long Answer Questions

1. Draw a fixture for Single Knock-out Tournament with 11 teams.
2. Draw a fixture of 5 teams for Single League Tournament using Tabular Method.
3. Draw a fixture of Single League Tournament with 7 teams using Cyclic Method.
4. Write the merits and demerits of Single League Tournament.
5. Draw a fixture for Single League Tournament with 6 teams using Staircase Method.
6. List and explain different types of competitions that are being organised at International level.
7. List and explain different types of competitions that are being organised in India.
8. Explain in detail about the Olympic and Paralympic Games.

II. Short Answer Questions

1. What is a tournament?
2. List different types of tournaments.
3. What is the full form of the SGFI Games?
4. What were the early National Games called?
5. Where were the inaugural Asian Games held?
6. Who was the founder of Commonwealth Games?
7. Where and when were the Winter Olympic Games started?
8. Who was the founder of Modern Olympic Games?
9. When were the first Ancient Olympic Games held?

III. Fill in the Blanks

1. Knock-out tournament is also termed as _____.
2. In Single Knock-out tournament, total number of matches with 16 teams will be _____.
3. Staircase Method is a type of _____ tournament.
4. Number of byes in Single Elimination Tournament with 29 teams will be _____.
5. No. of byes in a Single Knock-out Tournament for 51 teams with special seeding for 4 teams will be _____.
6. Olympic Games were started in _____.
7. Paralympic Games were started in _____.
8. Commonwealth games were founded by _____.



9. National games in India are held at an interval of _____ years.
10. School games in India are organised by _____ .

IV. State whether True or False

1. There will be no byes in a Single Knock-out tournament having 32 teams.
2. League tournament is also termed as Round Robin Tournament.
3. Total number of matches in a Single League Tournament with 6 teams will be 15.
4. Number of matches in the first round in a Single Knock-out Tournament with 27 teams will be 12.
5. Total number of matches in Double League Tournament with 7 teams will be 21.
6. School games in India are organised by SGFI.
7. Abhinav Bindra won gold medal in Shooting in 2016 Rio de Janeiro (Brazil) Olympic Games.
8. Sakshi Malik won Olympic medal in Wrestling.
9. Devendra Jhajharia won medal in Paralympic Games, Rio de Janeiro (Brazil), in Javelin event.





11152CH11

ADVENTURE SPORTS

11

Adventure sports are extraordinary activities performed by individuals who are in search of excitement, extra enthusiasm and have the desire to explore nature. These sports are invented out of adventurous interest of individuals who want to explore nature out of curiosity. During the exploration, different types of adventure sports were discovered, such as, rafting, surfing, mountaineering, trekking, etc. Participation in such sports also helps to fulfil the purpose of satisfying robust human behaviour. These sports are classified as—

1. Adventure water sports
2. Adventure land sports
3. Adventure air sports

Further, the adventure sports in all three categories are also divided separately for water (rafting, surfing, etc.), land (mountaineering, trekking, etc.) and air (paragliding, jumping, etc.). The camping has already been discussed in the Class IX book. Here, in this chapter, paragliding and surfing are explained for understanding as these are most exciting and classical adventure sports.



Fig. 11.1: Paragliding

PARAGLIDING

Paragliding is the recreational and competitive adventure sport for flying paragliders. Paragliding is engine less or motor free sport and practised by the adventurous people. This type of sports need courage and need to be decisive.

Historical Development of Paragliding

Domina C. Jalbert, in 1954, invented advanced governable gliding parachutes with multi-cells and controls for lateral glide.

In one of the articles, in *Flight* magazine, Walter Neumark predicted that a glider pilot would be able to launch himself by running over the edge of a cliff or down a slope. French engineer Pierre Lemoigne produced improved parachute designs that led to the Para-commander.

David Barish, during 1965, developed the 'sail wing' that was used to sail slope-soaring as a summer activity for ski resorts.

In the year 1985, Canadian authors Patrick Gilligan and Bertrand Dubois from Switzerland, wrote the first flight manual with the title 'The Paragliding Manual', officially coining the word 'Paragliding'.

Classification of Paragliding

Paragliding is classified as—

1. Light-weight gliding
2. Free flying glider
3. Foot-launched glider: Foot launched glider is like an aircraft with no rigid primary structure.

Sitting Position

The paraglider (pilot) sits in a harness, suspended below a fabric wing comprising a large number of interconnected baffled cells. Wing shape is maintained by the suspension lines. Despite not using an engine, paragliders, flight can last many hours and cover hundreds of kilometers. Though, the norms for flight of one to two hours that covers around some tens of kilometers are considered valid for gliding purposes. By skillful exploitation of sources on lift, the pilot may gain height, often climbing to altitudes of a few thousand meters.

First World Championship 1989

The first official Paragliding World Championship was held in Austria, in 1989.

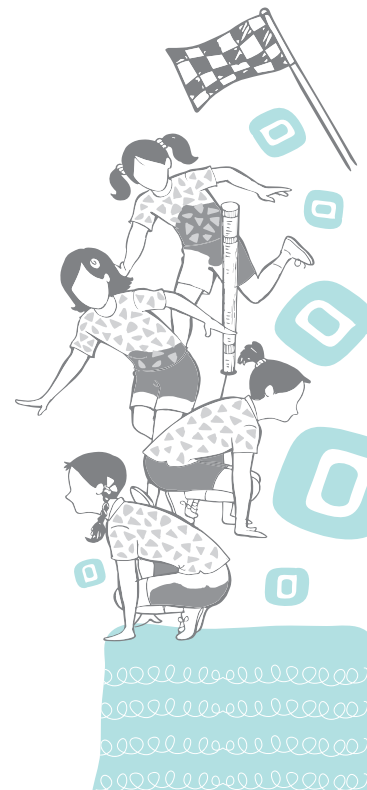

Do You Know?

Canadian Domina Jalbert invented and patented (in 1963) parafoil in an aerofoil shape; an open leading edge and a closed trailing edge, inflated by passage through the air.

Strength of Paraglider Structure

Paraglider lines are usually made from spectra that are immensely strong. For example, a single 0.66 mm diameter line (about the thinnest used) can have a breaking strength of 56 kg. Paraglider wings typically have an area of 20–35 square meters (220–380 sq ft) with a span of 8–12 meters (26–39 ft) and weigh 3–7 kilograms (6.6–15.4 lb). Combined weight of wing, harness, reserve, instruments, helmet, etc., weigh around 12–22 kilograms (26–49 lb).

Speed of Paragliders

The speed range of paragliders is typically 20–75 kilometres per hour (12–47 mph).

Carrying Capacity and Storage of Paragliders

For storage and carrying, the wing is usually folded into a stuff-sack (bag), which can then be stowed in a large backpack along with the harness. The complete equipment packs into a rucksack that can be carried easily on the pilot's back, in a car, or on public transport.

Instruments

Instruments used in paragliding are—

1. **Variometer:** The main purpose of a variometer is to help a pilot find and stay in the 'core' of a thermal to maximise height gain and, conversely, to indicate when a pilot is in sinking air and needs to find rising air. A variometer also indicates the climb rate or sink-rate with short audio signals (beeps, which increase in pitch and tempo during ascent, and a droning sound, which gets deeper as the rate of descent increases) or a visual display. It also shows altitude — either above takeoff, above sea level or flight level at higher altitudes.
2. **Radio:** Radio communications are used in training to communicate with other pilots, or to report where and when they intend to land. These radios normally operate on a range of frequencies in different locations. In rare cases, pilots use radios to talk to airport control towers or air traffic controllers. Many pilots carry a cell phone so they can call for pickup if they land away from their intended point of destination.
3. **GPS (Global Positioning System):** GPS is a necessary accessory while flying in competitions. The recorded



GPS track of a flight can be used to analyse the flying technique or can be shared with other pilots. GPS is also used to determine drift due to the prevailing wind when flying at altitude, providing position information to allow restricted airspace to be avoided and identifying one's location to aid the retrieval teams after landing out in unfamiliar territory.

Flying Techniques

There are different ways of flying as with all the aircrafts, launching and landing are done into wind. Paragliders, like hang gliders do not 'jump' at any time. There is one assisted launch technique used in flatland areas and two launching techniques used on the higher ground.

1. Forward launch: In low winds, the wing is inflated with a forward launch, where the pilot runs forward with the wing behind so that the air pressure generated by the forward movement inflates the wing.
2. Reverse launch: In higher winds, a reverse launch is used, with the pilot facing the wing to bring it up into a flying position, then turning around under the wing and running to complete the launch. Reverse launches have a number of advantages over the forward launch.

Landing

Landing a paraglider, as with all unpowered aircrafts which cannot abort a landing, involves some specific techniques and traffic patterns. Paragliding pilots most commonly lose their height by flying a figure of 8 in over landing zone until the correct height is achieved, then line up into the wind and give the glider full speed. Once the correct height (about a meter above ground) is achieved the pilot will 'stall' (pause) the glider in order to land.

Control through Speed Bar Mechanism

Paraglider can be controlled with the help of breaks and accelerator attached with the paraglider. These are the speed bar mechanism called control breaks, which are held in pilot's hand. Breaks are used to adjust the speed of the glider.

Types of Competitions

1. Cross-country flying is the classical form of paragliding competitions with championships in club, regional, national and international levels.

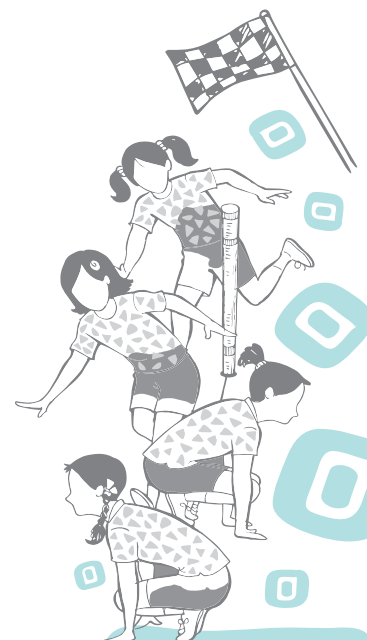

Do You Know?

George Freeth (8 November 1883–7 April 1919) is often credited as being the 'Father of Modern Surfing'. He is thought to have been the first modern surfer.

2. Aerobic competitions demand the participants to perform certain manoeuvres. Competitions are held for individual pilots as well as for pairs that show synchronous performances. This form is the most spectacular for spectators on the ground to watch.
3. In Bivouac flying competitions, a certain route has to be flown or hiked, which may take over several days.

Sky Parachutes have the maximum resemblance with paragliders but the sports are very different. Whereas with sky-diving, the parachute is 'only' a tool to safely return to earth after free fall, the paraglider allows longer flights and the use of thermals.

SURFING

The term surfing refers to the act of riding a wave, regardless of whether the wave is ridden with a board or without a board, and regardless of the stance used. Surfing is an event to be inducted in the Olympic Games from the year 2020. Surfing is a surface water sport in which the wave rider, referred to as a surfer, rides on the forward or deep face of a moving wave, which carries the surfer towards the shore. Waves suitable for surfing are primarily found in the ocean, but waves can also be found in lakes or rivers in the form of standing wave or tidal bore. However, surfers can also utilise artificial waves such as those from boat and the waves created in artificial wave pools.



Fig. 11.2: Surfing-1

Historical Development of Surfing

For centuries, surfing was a central part of ancient Polynesian culture. Surfing may have first been observed by the British explorers at Tahiti in 1767.

Governing Body

The highest governing body for surfing sport is known as International Surfing Association. It is played all over the world. In 1975, professional contests started. That year, Margo Oberg became the first female professional surfer.

Types of Surfing



Fig. 11.3: Surfing-2

1. **Stand-up Surfing:** The modern-day definition of surfing, most often refers to a surfer riding a wave standing up on a Surfboard; this is also referred to as stand-up surfing. Long surf-boarding and short surf-boarding are the two types of stand-up surfing. Both long and short surf-boarding have several major differences, including the board design and length, the riding style, and the kind of wave that is ridden.
2. **Body Surfing or Body Boarding:** The surfer riding a wave on a body board, either by lying on the belly, or drop knee, is called body surfing. In body surfing, the wave is surfed without a board, using the surfer's own body to catch and ride the wave, this is very common and considered to be the purest form of surfing.
3. **Surf Matting:** An other type of surfing that is surfed in inflatable mats, using foils, is called surf matting.
4. **Tow-surfing:** Tow-surfing is most often associated with big wave surfing with a motorised water vehicle, such as a personal watercraft, which tows the surfer into the wave front. Water-craft help the surfer to match a large wave's speed, which is generally higher than a self-propelled surfer can produce.

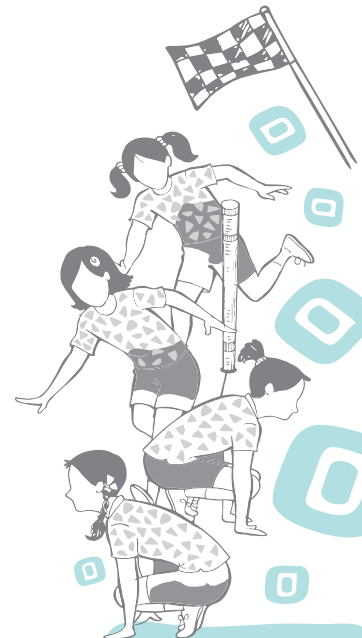

Types of Surfboard

A long board (10 feet) causes more friction with the water, and is slower than a smaller lighter board (6 feet). Longer boards are good for beginners, who need help in balancing. Smaller boards are good for more experienced surfers who want to have more control and manoeuvrability.

Dangers during Surfing

Seabed

The seabed can pose danger for surfers. If a surfer falls while riding a wave, the wave tosses and tumbles the surfer around, often in a downwards direction. At reef breaks and beach breaks, surfers have been seriously injured and even killed because of a violent collision with the sea bed, the water above which can sometimes be very shallow, especially at beach breaks or reef breaks during low tide.

Rip currents

Rip currents are water channels that flow away from the shore. Under the wrong circumstances, these currents can endanger both experienced and inexperienced surfers. Since a rip current appears to be an area of flat water, tired or inexperienced swimmers or surfers may enter one and be carried out beyond the breaking waves. Although many rip currents are much smaller, the largest rip currents have a width of forty or fifty feet. However, by paddling parallel to the shore, a surfer can easily exit a rip current.

Surfing related Sports

Surfing-related sports, such as, paddle boarding and sea kayaking do not require waves. Other water related sports such as kite surfing and wind-surfing rely primarily on wind for power, yet all of these platforms may also be used to ride waves. Recently the use of V-drive boats wave surfing, in which one surfs on the wave of a boat, has emerged.

Safety and Security in Paragliding and Surfing

The security and safety of the gliders and surfers have to be kept in mind as there is high risk involved during these adventure sports. Safety measure should be followed and observed by the individuals taking adventure sports.

1. A paraglider should be certified and highly skillful before taking adventure sports.



2. A paraglider should keep all type of safety instruments before going for paragliding. These instruments are Virometer, Global Positioning System and Radio to get update about all kinds of dangers.
3. During practice, proper safety equipments like helmet, knee guards, chest guards and other protective equipment should be worn.
4. Gliding should not be permitted without proper assistance (licensed personnel).
5. A surfer should recognise the wave current flowing in sea for keeping himself in the safe zone.
6. A surfer should also be able to recognise the deep face of the moving wave that can be dangerous sometimes to the surfer.
7. Surfer should practise his surfing skills in the artificially created waves before introducing himself in the deep sea.
8. Paragliders should inspect their paraglide breaks and other necessary lining for safety measures regularly.
9. Enough practice should be done before taking long route paragliding.
10. Fitness standard (physical and mental) should be maintained, which is considered as the key factor that helps in meeting out and taking quick decision during any untoward situation.

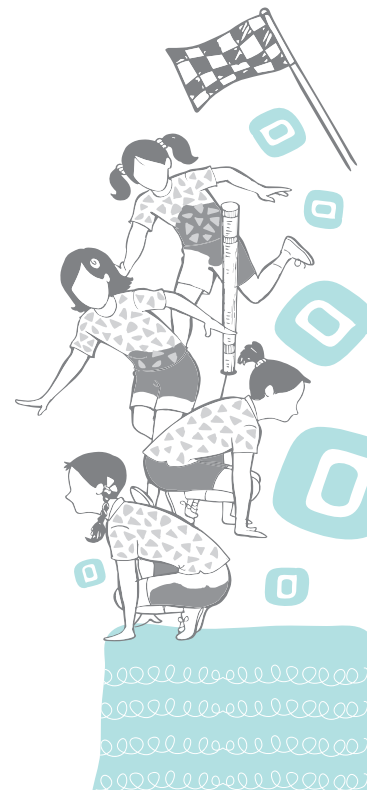

ASSESSMENT

I. Long Answer Questions

1. Write down the use of Variometer in paragliding.
2. Explain 'tow- surfing'.
3. Discuss the safety measures to keep in mind during paragliding.
4. Briefly explain Sea beds and Rip Currents.
5. How does Global Positioning System work?

II. Short Answer Questions

1. Name the person who invented paragliding.
2. Name the two flying techniques in paragliding.
3. Classify the categories of adventure sports.
4. In which year, the first world championship for surfing was held?
5. What are the different types of surfing?



FEEDBACK QUESTIONNAIRE

Please give your comments on the textbook by filling this feedback questionnaire. Please send the duly filled questionnaire to the undersigned.

Department of Education in Social Sciences, NCERT, Sri Aurobindo Marg, New Delhi-110016.

While answering a question if you find the space inadequate, please attach a separate sheet. All questions are meant both for teachers and students. You can provide your feedback in English or Hindi. Even parents if desite can respond.

Teacher/Student/Parent

Name _____

School Address _____

1. Do you find the textbook is easy to understand? Yes/No

2. Point out the chapters/pages where the language is difficult to understand.

Chapter No.	Page No.	Lines
_____	_____	_____
_____	_____	_____
_____	_____	_____

3. Do you think the content of the book is adequate to meet the requirements of the syllabus? Yes/No

4. (i) Point out the chapters which are lengthy.

(ii) Point out the chapters which are too sketchy.

5. Point out the illustrations which are not helpful in understanding the content.

Page No.	Illustration	Caption
_____	_____	_____
_____	_____	_____
_____	_____	_____



6. (i) Certain practical activities and games have been suggested. How many activities and games have you undertaken in your class? Mention them.

(ii) What difficulties did you face in organising these activities and games?

(iii) Would you like to suggest any activity(ies). Mention these.

7. Certain questions have been given in boxes in the text of the chapters.

- | | |
|--|--------|
| (i) Did you try to find out their answers? | Yes/No |
| (ii) Are these helpful in understanding the text of the chapter? | Yes/No |
| (iii) Do you find these questions interesting? | Yes/No |

8. (i) Do you find the exercise given at the end of each chapter in the textbook interesting? Yes/No

(ii) Point out the exercise which according to you should be modified.

Page No.

Exercise No.

9. Point out the printing errors, if any.

Page/Para No.

Error

10. Any specific comments/suggestions for overall improvement of the textbook.

